

Rochester Institute of Technology

## RIT Digital Institutional Repository

---

Theses

---

2004

### Refill system for laundry detergent

Sani Seesuchart

Follow this and additional works at: <https://repository.rit.edu/theses>

---

#### Recommended Citation

Seesuchart, Sani, "Refill system for laundry detergent" (2004). Thesis. Rochester Institute of Technology. Accessed from

This Thesis is brought to you for free and open access by the RIT Libraries. For more information, please contact [repository@rit.edu](mailto:repository@rit.edu).

**Thesis for the Master of Fine Arts Degree**

College of Imaging Arts and Science  
Rochester Institute of Technology

Title **Refill system for laundry detergent**

Submitted by Sani Seesuchart  
Date February 16, 2004

Thesis Committee Approval

**David Morgan**

2.25.04

CHIEF ADVISOR APPROVAL  
PROFESSOR DAVID MORGAN

DATE

**Stan Rickel**

2-25-04

ASSOCIATE ADVISOR APPROVAL  
PROFESSOR STAN RICKEL

DATE

**Deanna M. Jacobs**

3.8.04

ASSOCIATE ADVISOR APPROVAL  
PROFESSOR DEANNA JACOBS

DATE

**Patti Lachance**

4.9.04

SCHOOL OF DESIGN CHAIRPERSON APPROVAL  
PROFESSOR PATTI LACHANCE

DATE

I, Sani Seesuchart, hereby grant permission to the Wallace Library of Rochester Institute of Technology to reproduce this thesis in whole or in part. Any reproduction will not be for commercial use or profit.

**Sani Seesuchart**

3.8.04

SANI SEESUCHART

DATE

## **Acknowledgements**

I want to thank each individual listed below for giving me the necessary emotional support and constructive criticism to help me complete this project and my Master's degree.

Sirichai and Ruchanee Seesuchart, my parents

Jumroon Seesuchart

David Morgan

Stan Rickel

Professor Deanna Jacobs

AIA and The Starr Foundation

Rick Auburn

Natalie, Oou, Krisaya, Sampada, Piyas, John, Sean, Mien and all of my friends who gave me valuable advice and assistance.

## Contents

Project definition	1
Research: Case studies	2
Research: Refill	6
Research: Refill process	9
Analysis	14
Ideation	16
Design development: Bottle	20
Design development: Kiosk	29
Final design: System design	31
Final design: Bottle	33
Final design: Kiosk	35
Final design: Interface design	37
Conclusion	40
Bibliography	41

## Illustration Contents

Fig. no.	Label	Page
1	Milk refill in Germany	3
2	Restore refill process	4
3	Different sizes of bottle that Culligan offers to customers	5
4	Culligan refill station	5
5	Shopping	8
6	Choosing	8
7	Sorting	9
8	Usage	9
9	Keeping	10
10	Waiting	10
11	Taking the bottle back	11
12	Arriving at the store	11
13	Refilling	12
14	Loading	12
15	Preliminary sketch1	16
16	Preliminary sketch2	17
17	Preliminary sketch3	18
18	Preliminary sketch4	18
19	Preliminary sketch5	19
20	A flexible pouch with rigid spout	20
21	A flexible pouch with closure	20
22	Water container for camping	20
23	Collapsed bottle	21
24	Full bottle	21
25	Sketches regarding different orientations	21
26	Arranging composition of the bottle	21
27	Sketches considering stacking and nesting	22
28	Design Alternative 1	23
29	Design Alternative 2	23
30	Design Alternative 3	23
31	Design Alternative 4	24
32	Design Alternative 5	24
33	Design Alternative 6	24
34	Mock - up 2	25
35	Mock - up 3	26
36	Spout's mechanism detail sketch	27
37	Sketches of visual appearance	27
38	Mock - up comparing wire sizes	28
39	Sketches of Kiosk's form development	29

Fig. no.	Label	Page
40	The kiosk mock - up	30
41	Sketches of a mechanism inside the filling chamber	30
42	The refill system chart	32
43	A full bottle	33
44	Exploded view	33
45	Bottle design	33
46	Collapsed bottle	34
47	Stacked bottle	34
48	Kiosk design	35
49	Kiosk's part	36
50	A 55 gallon-sized module	36
51	The detail inside the filling chamber	36
52	Interface design	37
53	Interface design	37
54	Interface design	38
55	Interface design	38
56	Interface design	38
57	Interface design	39
58	Interface design	39

## **Project Definition**

Design Issues Seminar, the class I took before beginning my thesis, taught me to be a good designer by designing for a better world. Reading many books about green design and seeing people use big bulky plastic containers for laundry detergent and throw them away, led me toward the idea of becoming an environmentally concerned person. For these reasons, I picked my thesis topic on how to help people reuse their laundry detergent bottles. My thesis, a refill system for laundry detergent, will encourage people to reuse their bottles by creating the most convenient and economical design for the refill system.

A bottle, a kiosk, and its interface were designed to fit within the existing detergent distribution chain. The refill system goes from manufacturer to distributors and retailers. The refill process happens between customers and retailers. The collapsible bottle provides a convenient feature for customers. The kiosk was designed to create a pleasant environment in the grocery store. The concept of refilling increases sales for retailers because it encourages customers to come back for repurchase. If the designs work as I expect, people should willingly participate in this program, and the end result would be fewer landfills in the future.

## **Research: Case studies**

Refilling is already being used in particular regions. Normally it is suitable for small areas or specific groups of people. Case studies show how each system fits in its market and demonstrates the effectiveness and the process of the system.

Milk refill in Germany is related to people's buying behavior. As a result, it reduces the waste dramatically. This case study also shows how the system fits in its particular market segment.

Restore, a maker of refillable detergent, proves that the effectiveness of the system depends on monetary value. They give a discount as a reward to customers who make repeat purchases (by refilling their product). Restore also shows that the refill system can be done successfully in a green retail market where their customers are environmentally - concerned people.

Since Culligan sells water separately from the bottle, their refill price is much cheaper than normal bottled water. Culligan is also proof that a refill system is possible in a bigger scale market such as Walmart.

Particular case studies have been examined on the following pages with the intention of identifying connections to, and inspiration for, this thesis study.





Fig. 1. Milk refill in Germany

## Milk refill in Germany

A self-dispensing milk refill machine has been used throughout the Tengelmann supermarket chain in Germany since 1988. Glass and recyclable plastic bottles measuring one liter are purchased at the store and filled with milk at the machine. Milk bottles in Germany are sold by the crate. When emptied, they are cleaned and brought back for refilling by the customer without limit to the number of times they can be used. In Munich alone, the system resulted in the saving of 3,700 tons of packaging waste in one year.

## Design considerations

This system was studied in order to understand how the design (pumping device) fits suitably in its environment. The pumping device looks compact and easy to use. From the store's perspective, this dispensing machine is able to fit suitably in the supermarket's cooler. They do not need to install any new equipment or lose more shelf space. German people buy milk by the crate, which means they buy in large volumes at a time. This point assures more sales for grocery stores and it is also convenient for customers because they do not have to go shopping everyday.



Fig.2. Restore refill process

## Restore Refill product

Restore, a “green” retail store in St. Paul, Minnesota, sells plant-based laundry detergent. The refill station dispenses six cleaning products, but its size is compact. Customers come back repeatedly to the store with empty bottles and refill them. After the refill, they get a coupon for \$1.00 off the original price. The company states in their website that the refill system drives customers to make repeat purchases for their products. Their sales have increased 88% or more during the pilot program year with the Restore Refill Station. Their staff and customers think this plant-based product conveys environmental benefits at the same price as chemical-based laundry detergent.

## Design considerations

This project shows that a refill system is successful in a niche market. The strength of this program is the \$1.00 off the product price. But the weak point is the process at the check out is quite redundant. Customers get the coupon printed within the store, but it is not distributed anywhere else to advertise the store. They also have to deal with paper waste after the cashier scans the barcode.

## Culligan

Culligan sells water filter equipment to grocery stores. The company installs a water filtering unit in the back room of the store. The advantage of back room installation is that the treatment equipment keeps service personnel off the retail floor. It also processes water to wherever it is needed throughout the store. At the front, the refill kiosk sells water to customers. Culligan sells different sizes of bottles according to customers' need. The price for refilling is only 33 cents a gallon, which is much cheaper than bottled water.

### Design considerations

This system shows how Culligan deals with their customers and retailers. For customers, they offer value to draw customers back for repeat purchasing; they also offer different sizes of bottles for different usages. For retailers, they offer multiple functions. The filter unit is not only dispensing water for customers but also being used as a water filter throughout the store. However, the back room installation restricts the location of the dispensing machine. The kiosk has to be located near the wall, sometimes separate from other water items, which makes it difficult for customers to find.



Fig. 3. Different sizes of bottle that Culligan offers to customers



Fig. 4. Culligan refill station

## Research: Refill

In Thailand, most of soft drink containers are returnable glass bottles. These returnable glass bottles are sold at small grocery stores, which are owned by local people. These small grocery stores are located in every community. Bottles are delivered from the manufacturer by a truck that comes to each community every week. This truck also takes empty bottles back to the manufacturer for refilling. The returnable glass bottle system is successful because the owners of the grocery stores have to pay a deposit for the bottles. It is their responsibility to contact every customer who has a bottle to return it. In the US, it is impossible to do this on such an individual basis and research at [www.informinc.org](http://www.informinc.org) indicates that the reasons are:

1. Lack of space for storing and washing empty bottles;
2. Major capital investments needed to create space for the equipment and bottles;
3. Retailers' and wholesalers' reluctance to handle returned bottles;
4. Consumer resistance to the scuffed appearance of refillable bottles after several trips; and
5. Low return rates

From this research, it is obvious that the reasons involve not only private sectors (customers), but also business sectors (retailers, wholesalers, and manufacturers).

The questionnaire on the refill system at the store was given out to 20 students from different majors at RIT. The questionnaire was used to ask their opinion on the refill idea and their detergent usage. The next page is the questionnaire with the results.

## Questionnaire

	No. of people
	Rating number
	Average Value
	Percentage

1. How old are you
- |    |    |
|----|----|
| 1  | 5  |
| 2  | 10 |
| 12 | 60 |
| 3  | 15 |
- a. 36 and up  
b. 30 - 36  
c. 24 - 30  
d. Less than 24
2. Rate your environmental concern behavior
- |    |    |
|----|----|
| 2  | 10 |
|    |    |
| 13 | 65 |
| 3  | 15 |
- a. Super strict - do whatever I can do - use cloth bag when shopping, recycle all the bottles.  
b. Do regularly  
c. Not doing at all
3. Do you go grocery shopping directly from home?
- |   |    |
|---|----|
| 3 | 15 |
| 3 | 15 |
| 5 | 25 |
| 6 | 30 |
- a. No, I go from my office / school.  
b. Yes  
c. Sometimes  
d. Mostly
4. How often do you go grocery shopping?
- |   |    |
|---|----|
| 6 | 30 |
| 4 | 20 |
| 7 | 35 |
| 1 | 5  |
- a. Once a week  
b. Twice a week  
c. Once in two weeks  
d. Once a month
5. How often do you buy laundry detergent?
- |   |    |
|---|----|
| 2 | 10 |
| 8 | 40 |
| 8 | 40 |
- a. Once a month  
b. Once in three months  
c. Once in more than three months
6. Rate the factor which influences you in doing reuse, refill, recycle (5=the most, 1= the least)
- | 5 | 4 | 3 | 2 | 1 | Ave. |
|---|---|---|---|---|------|
| 7 | 4 | 0 | 1 | 1 | 2.70 |
| 2 | 6 | 4 | 1 | 1 | 2.45 |
| 8 | 3 | 3 | 2 | 0 | 3.25 |
| 0 | 1 | 2 | 4 | 3 | 1.05 |
| 0 | 0 | 1 | 0 | 0 | 0.15 |
- \_\_\_ Convenient enough  
\_\_\_ Money redeemed  
\_\_\_ My environmental concern  
\_\_\_ Coolness of being a green person  
\_\_\_ Other
7. Rate the factor (1 - 5) that discourages you from doing reuse, refill, recycle for laundry detergent. (5=the most, 1=the least)
- | 5 | 4 | 3 | 2 | 1 | Ave. |
|---|---|---|---|---|------|
| 6 | 2 | 5 | 1 | 1 | 2.80 |
| 3 | 7 | 1 | 1 | 1 | 2.05 |
| 5 | 1 | 0 | 5 | 3 | 2.10 |
| 5 | 1 | 6 | 1 | 1 | 2.50 |
| 0 | 2 | 0 | 0 | 0 | 0.40 |
- \_\_\_ Bottle is so big and heavy that I don't want to take it back.  
\_\_\_ I want to carry it back but the place is not convenient for me.  
\_\_\_ It's not what people normally do.  
\_\_\_ I don't have time to do complicated process.  
\_\_\_ Other

From the results of this questionnaire,

Most of the samples are in the age of 24 - 30 years old. Thirteen of them are doing something for the environment regularly.

The two factors that influence people to refill are;

- their environmental concerns.
- the convenience of refilling

The two factors that discourage people from doing refills are;

- a problem of carrying the large bottle.
- time consuming for a complicated process.

From this data, the design will focus on how to reduce the size of the bottle and make the refill system convenient for users.

## Research: Refill process

Because the detergent refill system for the mass market does not exist at the present, the research for refill processes was done in order to understand any possible problems associated with this product. In each stage, I define the possible behaviors and analyze the problems in order to design the system functionally.

### 1. Choosing

Customers will choose a product they like from the shelf at the grocery store. The detergent is sold in a 100 oz. HDPE bottle located in the same aisle as the refill machine.



Fig. 6. Choosing

### 2. Shopping

Shopping is the stage before and after choosing a detergent. When customers shop for other grocery items, they can take either shopping carts or shopping baskets with them.



Fig. 5. Shopping

### 3. Sorting

Customers will sort their groceries after they are home and put everything away. The majority of people who live in houses with washers and dryers will keep the detergent bottles in the laundry area.



Fig. 7. Sorting

### 4. Usage

From the questionnaire, for most of the samples, this stage lasts about three months (for a 100 oz. bottle with regular use). At the end of this stage, before the bottle is empty, there is some overlapping time when people need two bottles. Therefore, they would need a refill method that is easy to use or to change to the second bottle.

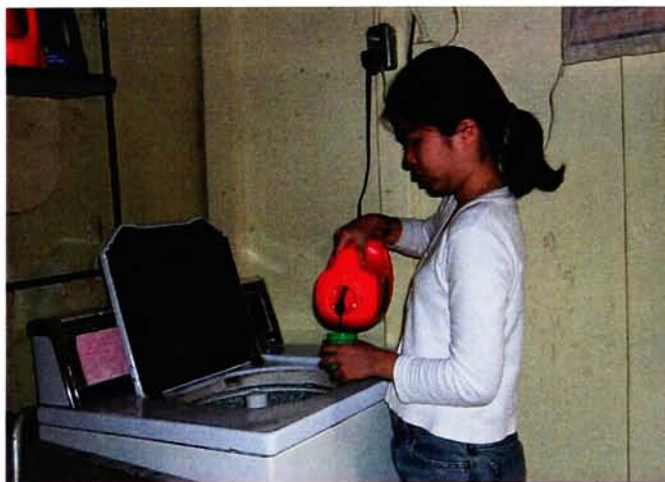

Fig. 8. Usage



## 5. Keeping

Keeping is the stage when users are not using the detergent. People would keep the bottle near the washer and dryer with other laundry supplies. A problem arises when there are people who are not in the same family living together, such as roommates. How would they separate their bottles from others?



Fig.9. Keeping

## 6. Waiting

After the bottle that is currently being used is emptied, people would keep it in a spot that they can obviously see before they go shopping, such as:

- near the recycle bin
- next to the exit door
- in the garage
- near the washer



Fig.10. Waiting

## 7. Taking it back

Users would take the empty bottle back to the place where they bought it. They would carry it by hand from their home to the car, then from the car to the store's parking lot. A possible problem for this step might occur where the majority of people don't have cars, such as in large cities. It might be hard for them to carry the bottle from home to office, to the store, and then back home later on.



Fig. 11. Taking the bottle back

## 8. Arriving at the store

Customers would take the shopping cart or basket with them, put the empty bottle in the cart and then enter the store. The problem in this step would arise with the store. Because customers have to take the same product back into the store, the system must help the store to prevent customers from switching the old bottle they took from home with the new one on the shelf.



Fig. 12. Arriving at the store

## 9. Refilling

The refill machine would be located in the same aisle as the bottled-laundry detergent. The machine would fill by weight or volume. Customers would put the bottle filled with laundry detergent back in their shopping cart, and then continue shopping and proceed through the checkout at the end.



Fig. 13. Refilling

## 10. Loading

After customers are done shopping, they would take the shopping cart with them to the parking lot and load the detergent with other grocery items into their car, or in the case for people who don't have a car, they would take the bottle, walk to the bus stop, subway, or directly back to their apartment.



Fig. 14. Loading

## **Analysis**

As my research indicates, in order to make the process convenient, the refill system must meet the following criteria:

### **1. Convenience**

Convenience is the first priority that concerns people when they have to experience a new routine. The design must first take into consideration the usual behavior of people who go to grocery stores. The design must fit in with their everyday lifestyle. The problems that must be solved are:

#### **1.1 Size of the bottle**

At present, the bottle for laundry detergent is big and bulky, but it is a disposable product. The size of the bottle would be a critical problem that must be solved. The solution might be either to reduce the size of the bottle or to have customers transport the product in a new form of packaging.

#### **1.2 Convenience of refilling**

The process of refilling is also important. When users go to the refill kiosk, they have to carry something with them. At the refill station, the kiosk must provide the easiest way to fill up the detergent by making it a hands-free process.

The other main concern of most people is time. The refill process should not be a time-consuming process. It should save time for the customer as much as possible. The system should be designed to be easy to access and easy to understand.

#### **1.3 Bottle sanitation**

Because a refillable bottle means to use of the same bottle over and over, sanitation is also an important aspect that must be addressed while designing the system. The solution might be to limit the number of refills or to design a bottle that is easy to clean.

#### 1.4 Location

The location should be in the places where people usually go. It should be the place that fits into their lifestyle suitably, such as a supermarket or stop and go mart in a gas station.

#### 1.5 Easy to transport

According to my research, the people involved in the refill would be both private sector (customers) and businesses sector (retailers and manufacturers). Therefore, the design must provide convenience to businesses too. In this case, in order to make this system effective, the design must provide the convenience of stacking and nesting aspects of packaging for easy transport and retail shelving.

1.6 Easy for the retailers to maintain the refill kiosk with minimal labor costs.

### 2. **Motivate people to refill**

Besides the convenience, customers might need some incentive to draw them back to the store. As seen from the case studies, one effective example is monetary value. The solution could be either to have them buy the bottle separately from the detergent or to give them a discount for second time buyers.

### 3. **Make less waste**

My intention is to make less solid waste by simplifying the filling process so that it could fit in with people's lifestyles and they would use it in real life. The end result of the system should reduce the total amount of solid waste that would go into landfills.

## Ideation

### Design alternative 1

Time saving is the main objective for this idea. By using an individual filling unit, customers don't need to wait while the machine is filling up the bottle.

Customers would buy a regular detergent bottle. After it is empty, they would take it back to the supermarket. The shopping cart has a special dock to put the bottle on. At the refill station, customers would push the shopping cart into the kiosk. The individual refill unit would snap to the shopping cart automatically. Customers would continue shopping with the refill unit snapped onto the cart. Meanwhile, the refill unit dispenses the detergent into the bottle located on the dock. After they finish shopping, the customer would go to the checkout. The staff would take the refill unit off the shopping cart and scan the detergent's barcode.

The individual refill unit design saves customers' the time of waiting for the machine to refill the product. But from the stores' perspective, they would not agree to spend extra money on hiring an employee to take the unit back and forth from checkout to storage then to the refill station.

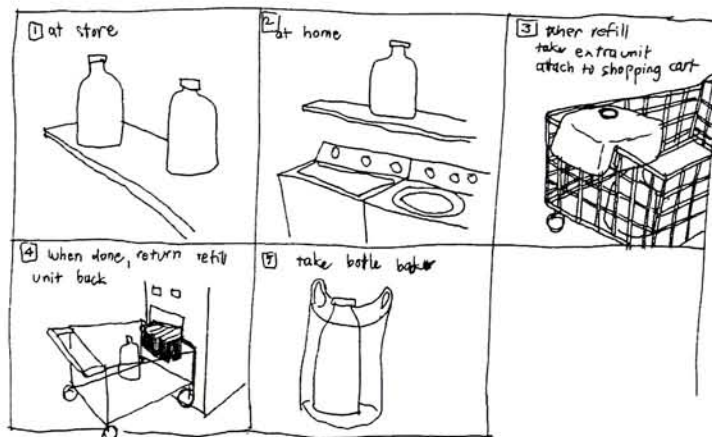

Fig. 15. Preliminary sketch1

## Design alternative 2

The second idea comes from the refill pouches that are used throughout Europe.

A first time user would buy a set of pouches containing the proper amount of laundry detergent for one time use. The user would collect emptied pouches together in order to take them back to the supermarket for refilling. After each pouch is refilled individually, the customer would take them back home and attach them to the pouch holder for the next usage.

A small pouch is very useful for a customer because it is compact. But customers have to carry a lot of individual pouches and it would take a long time to fill up all the pouches.

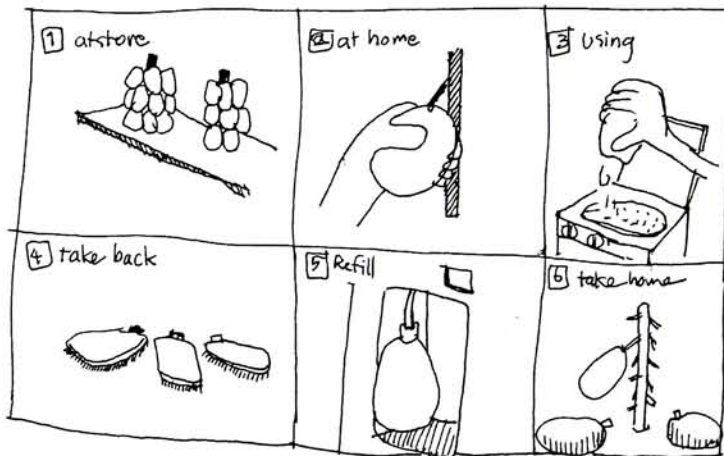

Fig. 16. Preliminary sketch2

## Design alternative 3

This idea is an option for refills at different locations other than the supermarket. With the special dock attached to the car's trunk, the bottle can be carried securely to the stop and go mart in the gas station. By opening the trunk and filling up the same way as filling up gas, users don't have to carry big, heavy bottles back and forth between their car and the refill station located inside the supermarket.

This idea is very convenient for customers because they do not have to carry the bottle around. But it would be redundant if customers

have to stop by a gas station after they shop at grocery store just to refill a bottle of laundry detergent.

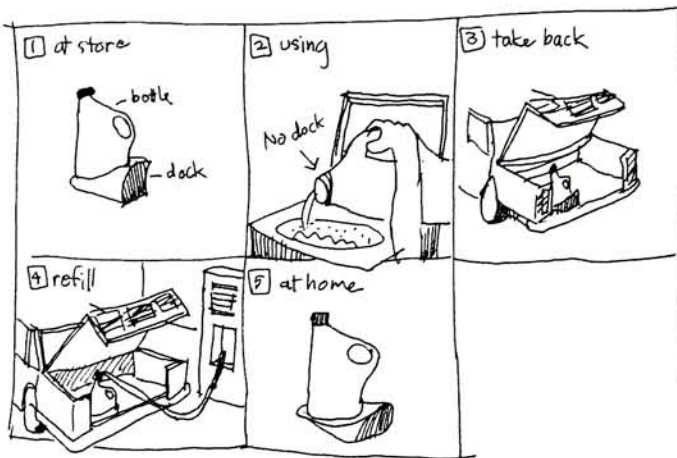

Fig. 17. Preliminary sketch3

#### Design alternative 4

Because the bottle must be easy to carry around, this idea divides the bottle into two parts: body and spout. The body is used to hold liquid. The spout is used to pour liquid in different orientations and to carry detergent from the refill station back to fill the bottle. In order to make it portable, the spout would be made from flexible material so that it can be shaped and attached to a human body.

This idea introduces the most convenient and creative way to carry the detergent bottle from home to shopping places. The disadvantage for this idea is its complicated process of adjusting and changing the shape of the spout. There is also a possibility that this process could cause a mess from spilling detergent.

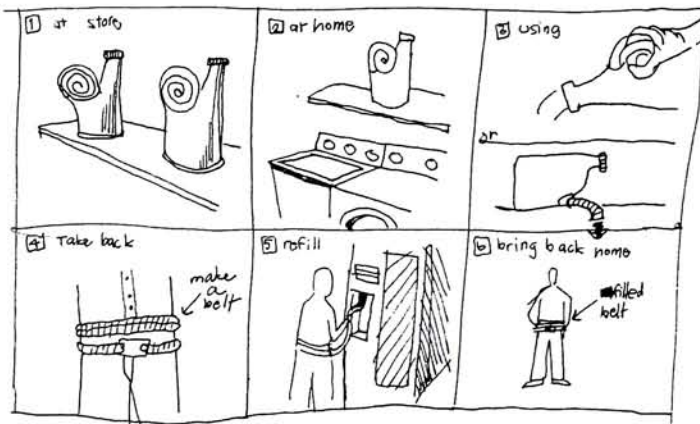

Fig. 18. Preliminary sketch4



## Design alternative 5

The goal of this idea is to combine rigid and flexible packaging. The combination of both kinds of packaging makes the bottle collapsible, yet shapable. Customers buy a gallon-sized bottle with detergent. After it is emptied, they take the collapsible bottle back to the store to refill it. The refill kiosk is thus easy to use because it works like a normal dispensing machine that people are using at present.

This idea is simple and easy to use. By using the benefit of flexible packaging, the bottle is easy to carry around and it is resealable. The only thing that needs to be improved is the function of the bottle. As in this sketch, the round bottomed bottle is unable to stand. It is also hard to pour.

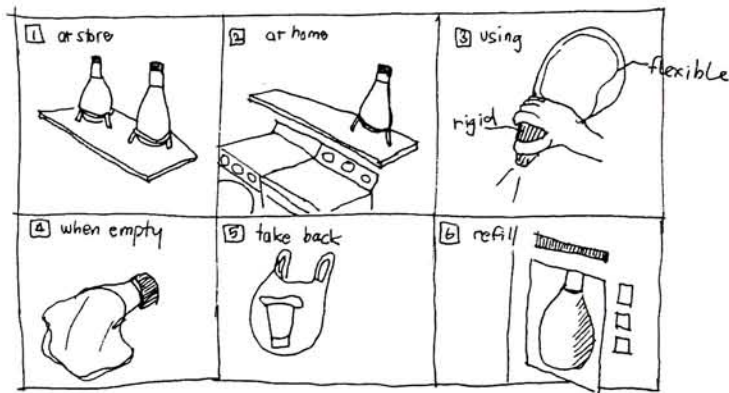

Fig. 19. Preliminary sketch5

## Design development: Bottle

After the initial brainstorming from the ideation stage and analysis, I had a better understanding of the priority for choosing each idea for developing it into a functional product.



Fig. 20. A flexible pouch with rigid spout

Design alternative 5 was chosen because it affords the most simple, convenient, and practical system. The process of bringing the bottle back to the grocery store is simple and convenient. Customers do not have to waste their time in the process. Grocery stores do not have to pay extra money for their employees. A manufacturer does not have to distribute their products to a totally new channel, and the bottle is easy to produce in mass production.

The design development will focus on bottle orientation and practicality of the bottle for both customer and store uses.

Below are consumer products that combine flexible and rigid packaging, including such items as a juice pouch and a water container for camping.

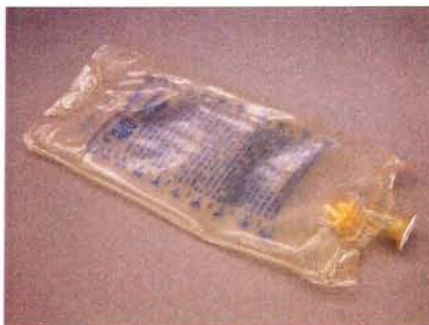

Fig. 21. A flexible pouch with closure



Fig. 22. Water container for camping

## Design development: Bottle

### Sketches 1

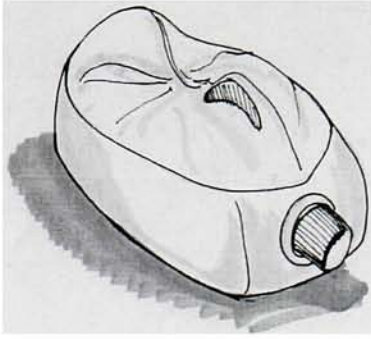

Fig.23. Collapsed bottle

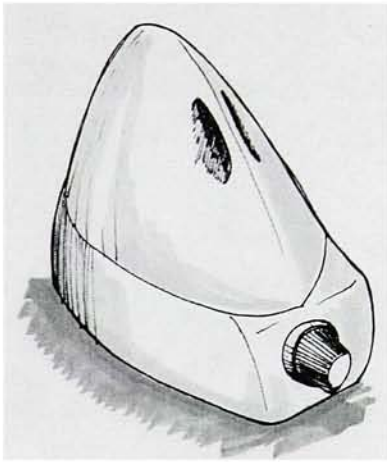

Fig.24. Full bottle

My first sketches combined rigid and flexible packaging, forming a single unit bottle. I designed the orientation of the bottle to make it easy to pour and handle so that it functions properly.

These sketches solve a problem from the ideation stage. It is able to both stand and collapse. But when it is collapsed, the size reduces to only a third of the normal size. Because the position of a spout, a handle and a body were not arranged properly, the decision regarding which part should be rigid or flexible was not yet made.

Issues to consider:

A soft handle is harder to grasp than a rigid material. Consider designing various closures and orientations. Also be concerned about the function of the bottle for stacking and nesting.

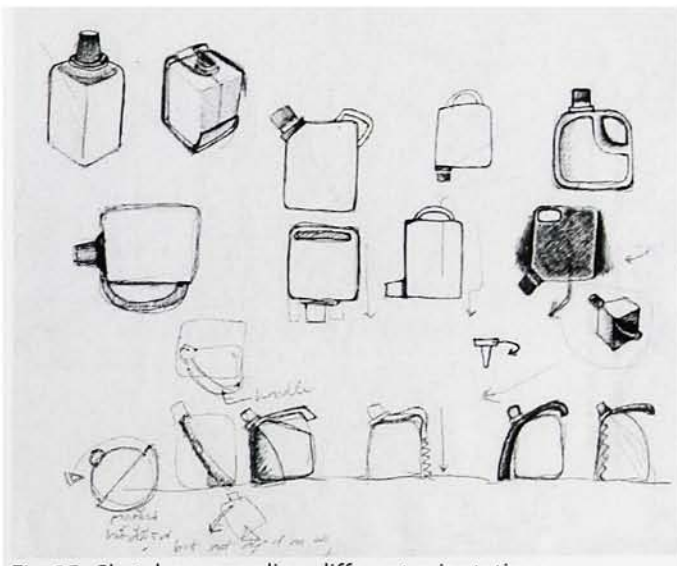

Fig.25. Sketches regarding different orientations

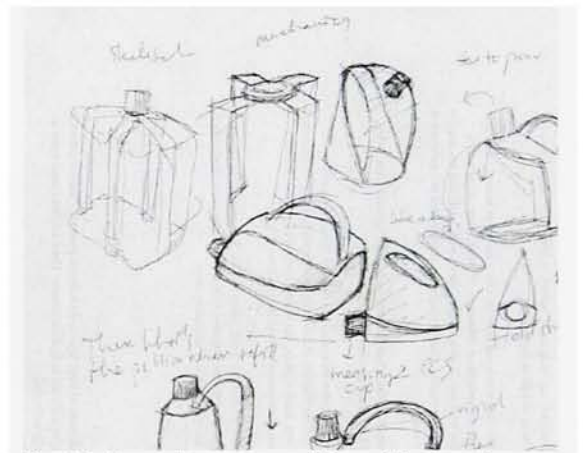

Fig.26. Arranging composition of the bottle

## Design development: Bottle Sketches 2



The second set of sketches focused on how to stack and nest the bottle. I separated the rigid part from the flexible element in order to reduce the cost of production. As a result, the separation of both parts makes visual organization easier. The rigid part is used to hold the bag's shape, and it also functions as a handle. The flexible part is used to contain liquid.

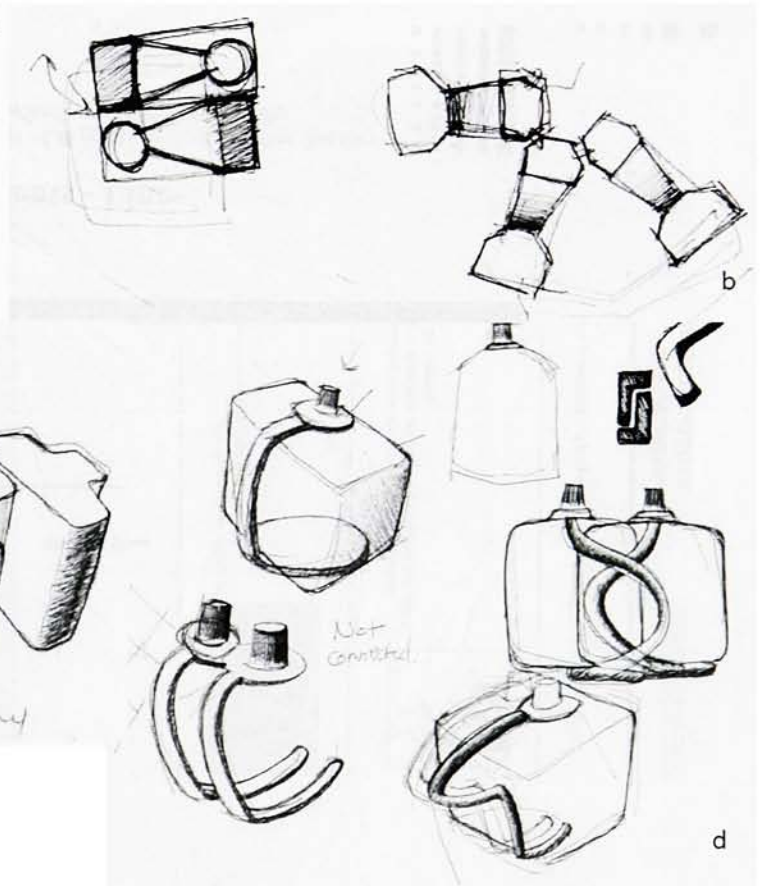

Fig. 27. Sketches considering stacking and nesting

**Design development: Bottle**  
**Mock - up 1**

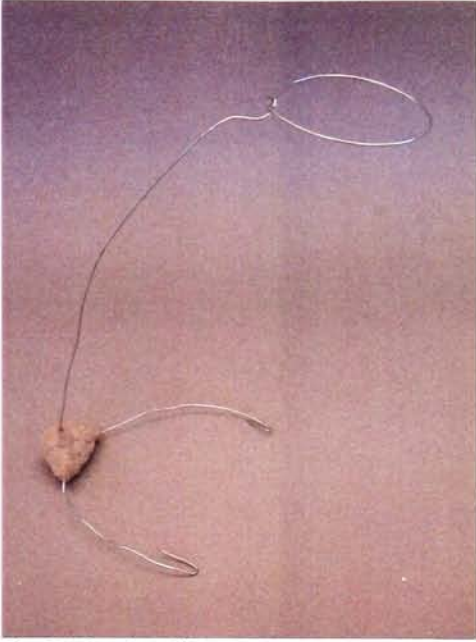

Fig. 28. Design Alternative 1

The main criteria I am considering throughout is still the pouring, stacking, and nesting process. Being able to use more than one orientation makes the bottle easy to use in two situations - heavy weight (full) and light weight (empty). The first orientation reduces the torque of pouring when the bottle is full, and the second orientation reduces the time of pouring when it is almost empty. The idea of changing the handle's position was also considered in these mock-ups.

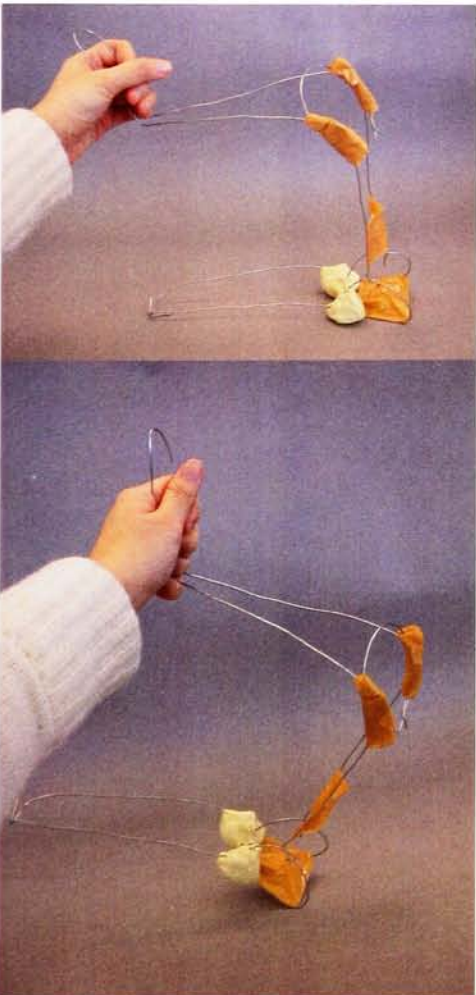

Fig. 29. Design Alternative 2

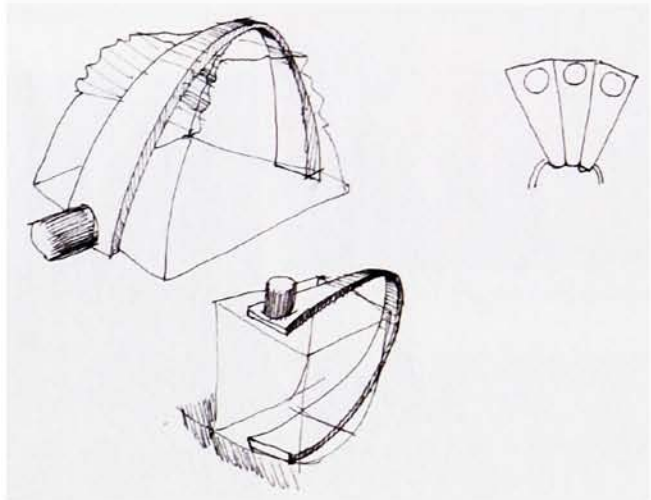

Fig. 30. Design Alternative 3

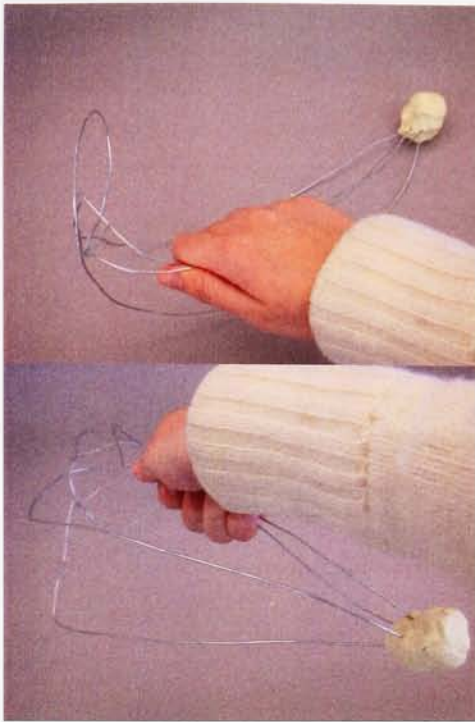

Fig. 31. Design Alternative 4

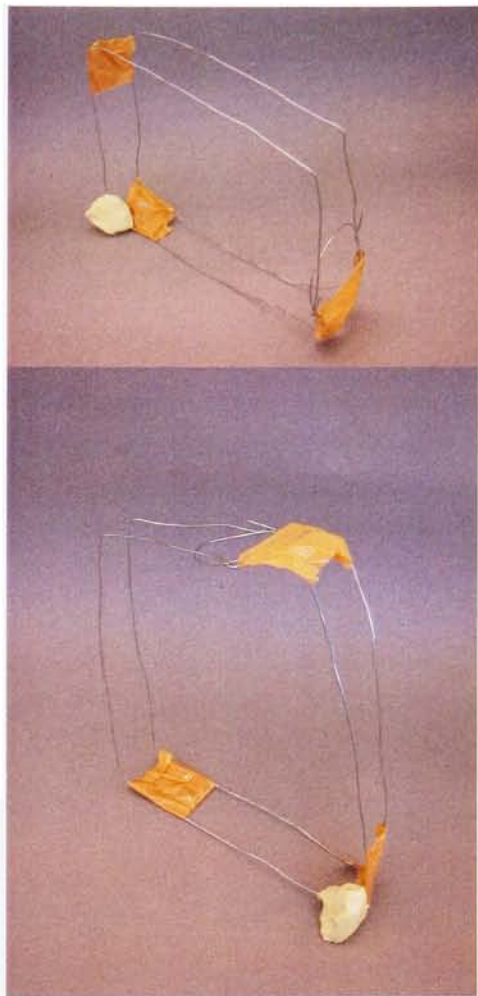

Fig. 33. Design Alternative 5

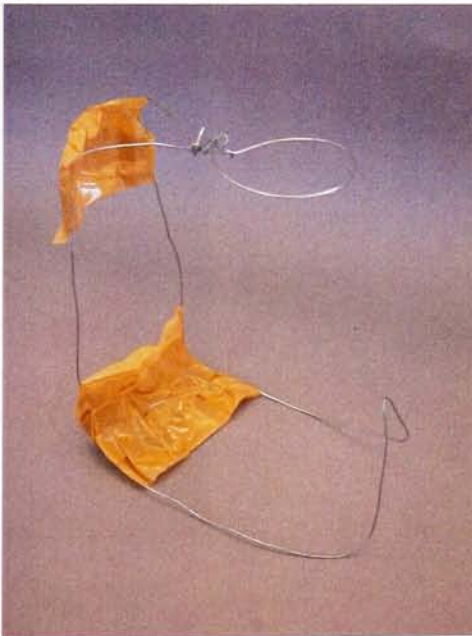
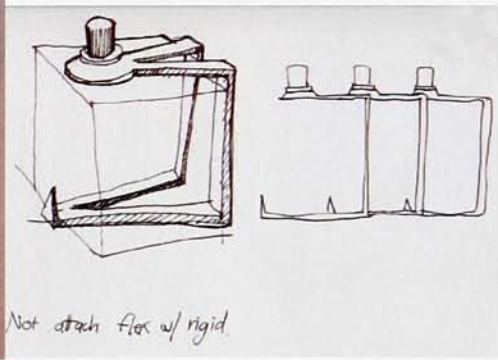

Fig. 32. Design Alternative 6



## Design development: Bottle

### Mock - up 2



Design alternative 2 was chosen because it is the easiest to use and to pour. In this mock up, after the experiment, the handle's position was changed from the original location to the top of the bottle. The position of connection and the joining method were also tested in this mock up.

Fig. 34. Mock - up 2

## Design development: Bottle

### Mock - up 3



The idea of using steel wire as a production material was introduced in the previous mock up. Because of its strength and sturdy looks that convey a sense of permanence to users, steel wire is the most suitable material for the refillable product. It is also easy to manufacture. This mock-up was used to show the visual appearance of the bottle.

Fig.35. Mock - up 3



## Design development: Bottle Detail design

Visual appearance and the spout's mechanism were developed at this stage. Two rings were designed to hold the collapsible spout onto the metal structure. The shape of a rigid part of the container and a handle were experimented with in order to find the most appropriate appearance. The position of the connection between flexible and rigid parts was also tested at this point.

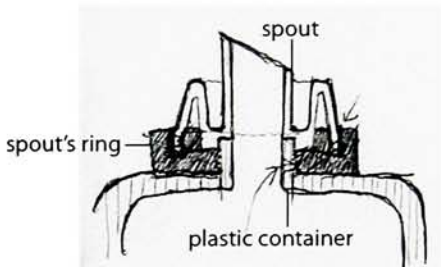

Fig. 36. Spout's mechanism detail sketch

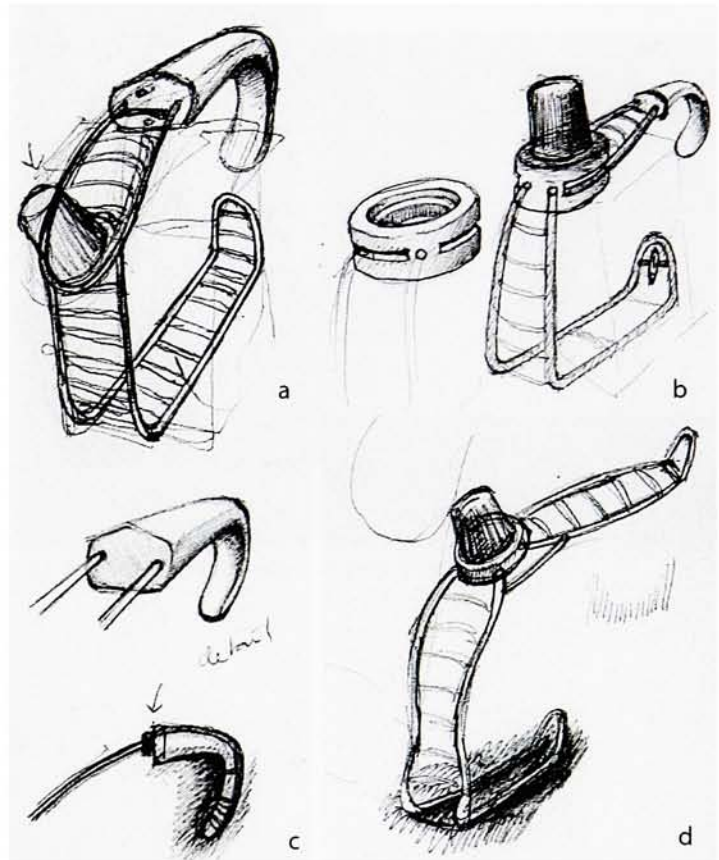

Fig. 37. Sketches of visual appearance

## Design development: Bottle

### Mock - up 4

These mock - ups were made in order to select the wire size (1/8 inch and 1/4 inch) that is appropriate for visual appearance. The strength of both wire sizes was tested at this stage.



Fig. 38. Mock - up comparing wire sizes

## Design development: Kiosk Sketches

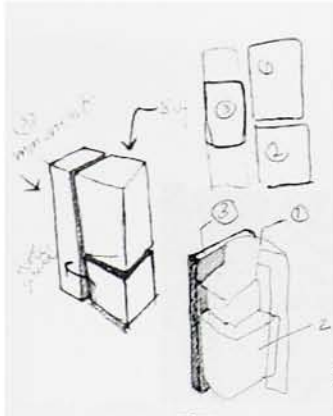

The kiosk has three major components: reservoir, interface and filling chamber. According to its function, I separated the kiosk's form into three blocks. The reservoir is divided into two blocks: the upper and the lower reservoir. The interface is located on the same block as the filling chamber. The kiosk's overall dimensions are 6'x2'x2'. The main objective of form development is to use block - like composition to reduce the size visually. By separating the three major components from each other, giving the appropriate orientation to each unit, the kiosk's visual appearance is reduced.

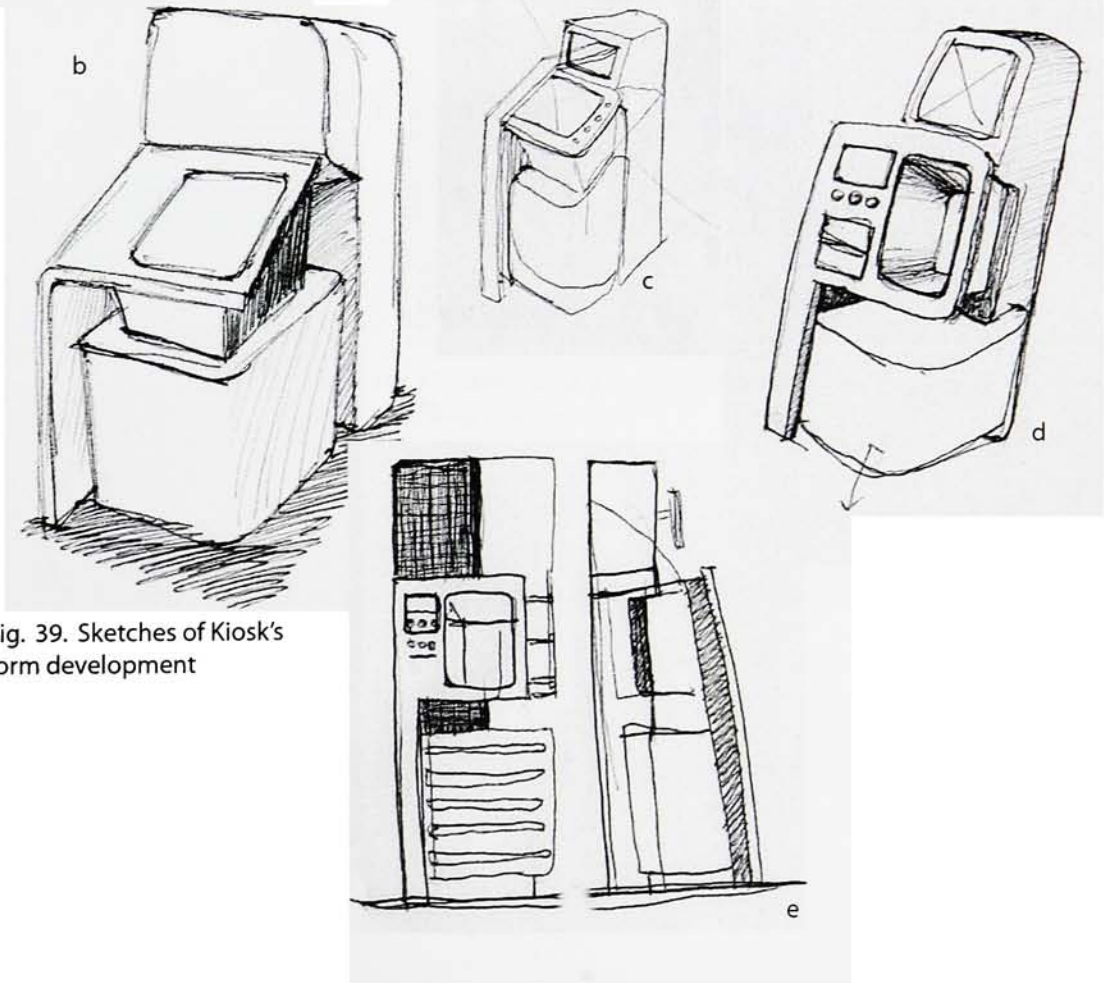

Fig. 39. Sketches of Kiosk's form development

## Design development: Kiosk Mock - up and detail design



The actual-sized mock-up was made in order to test human factors and interface design. This mock - up shows that the filling chamber needs to be developed because the bottle can not be placed firmly in the chamber. The position of buttons for the moving mechanism inside the machine also needs to be changed to the front because people can not reach them from the side.

The detailed sketch shows how the bottle could be placed and filled up steadily in the filling chamber.

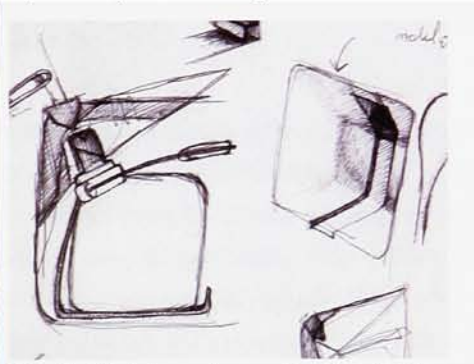

Fig. 41. Sketches of a mechanism inside the filling chamber



Fig. 40. The kiosk mock - up

## Final design: System Design

The final system consists of three products: the bottle, the kiosk and the interface design for the kiosk.

The chart on the next page shows the refill system that begins with the manufacturer. The laundry detergent is distributed in two sizes: a gallon-sized bottle for the customer and a 55 gallon-sized module for the refill kiosk. The manufacturer also distributes an empty flexible container, which is used to replace the older one for refill customers. The bottle, and the empty flexible container will be sold on a shelf in a grocery store. The module will dispense the refill detergent through the kiosk.

A first time user buys a gallon-sized bottle. When the bottle is emptied, the customer will take it back to refill it at the store, which is making a repeat purchase. Customers will expect to find the refill kiosk in the detergent aisle. After refilling, they will receive a coupon with a barcode. This coupon is used for two purposes: to help the store keep track of used bottles that are brought into the store and to give customers a cheaper detergent price (the price without charging for the bottle).

After the 55 gallon refill module is empty, the grocery store will send the module back to the manufacturer. They will fill it up with the detergent and will deliver the module back to the store to complete the refill cycle.

The trash that would be disposed of in a landfill would be the used collapsible container that would save space for a landfill in the future.

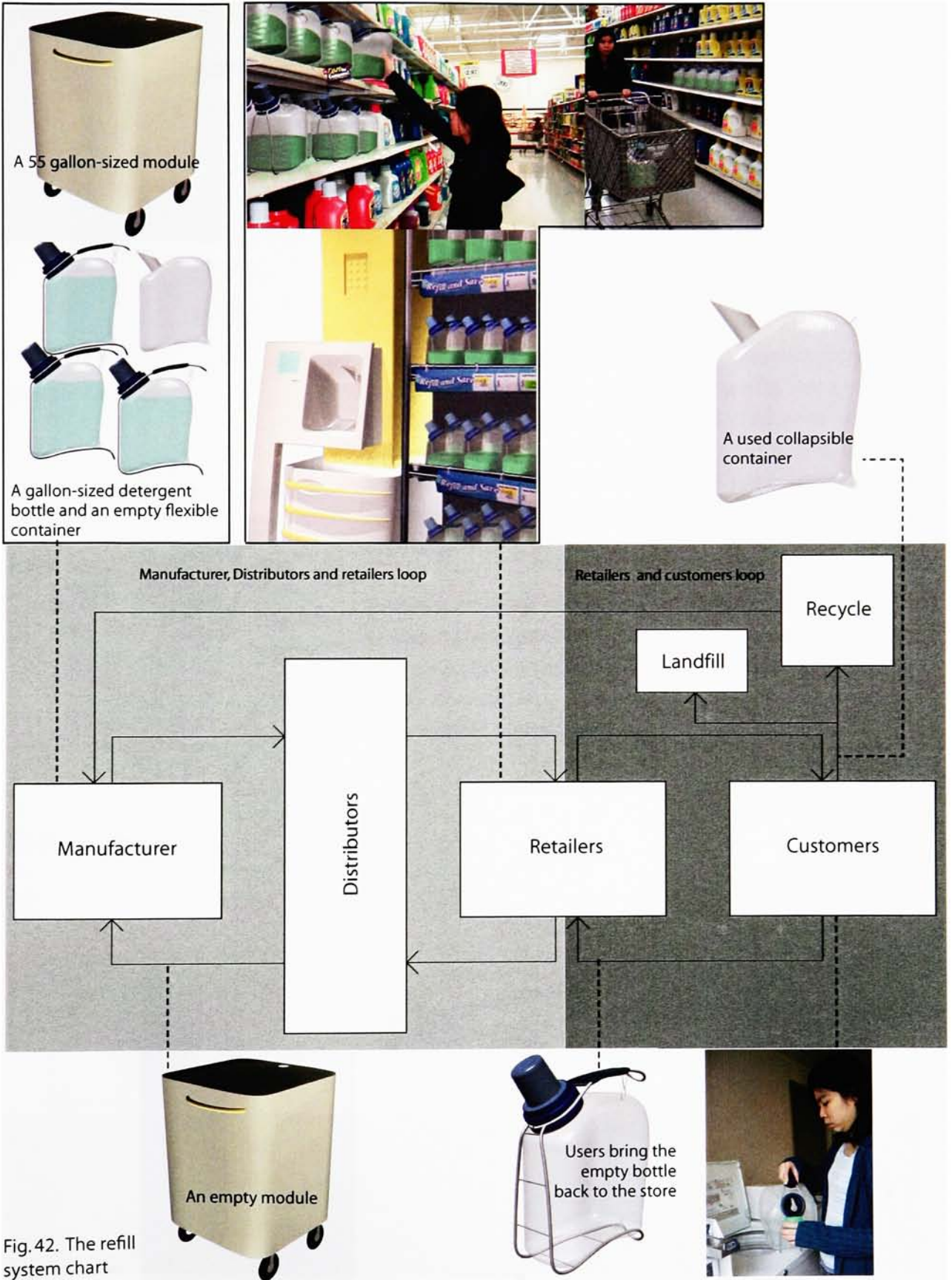

Fig. 42. The refill system chart



Fig. 43. A full bottle

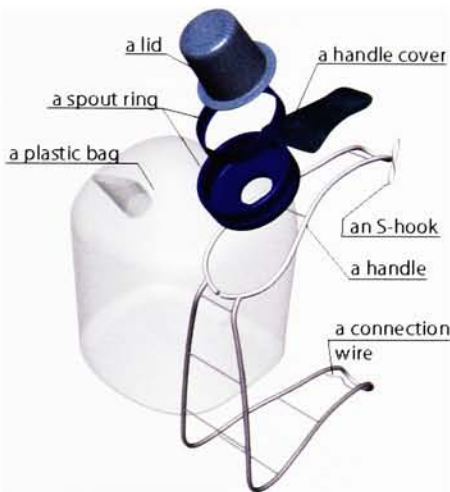

Fig. 44. Exploded view

## Final design: Bottle

There are six separate pieces in this bottle: a plastic container, a steel wire handle, a lid, an S-hook, a spout ring and a handle cover.

The plastic container is blow-molded into one piece with soft and hard parts. The soft part is for containing the laundry detergent. The hard part performs as a spout and a connection piece. The handle and the spout are located on top of the bottle. By tilting the bottle down, liquid can be poured easily. The S-hook and a connecting wire help to hold the container in place while pouring, even when there is a low level of liquid.

The handle and all the rigid parts can be separated from the soft container. To replace the soft container with the newer one, first unscrew the spout ring, then take the flexible plastic container off of the S-hook. Once the flexible container is released from the rigid part, it can be replaced with the newer one.



Fig. 45. Bottle design

The bottle was designed to be collapsible and stackable. Collapsing makes the bottle easy to carry from home to the grocery store. Stacking gives the benefit of easy transporting from manufacturer to retailers.



Fig. 46. Collapsed bottle



Fig. 47. Stacked bottle



## Final design : Kiosk

The kiosk is 6' tall, 2' wide and 2' deep. There are three elements interlocking together. The kiosk consists of four parts: the filling chamber, the interface, the lower reservoir and the upper reservoir. The tall yellow block is an upper reservoir. The upper white piece is the filling chamber and the interface. The lower white piece is used to contain a 55 gallon-sized module.

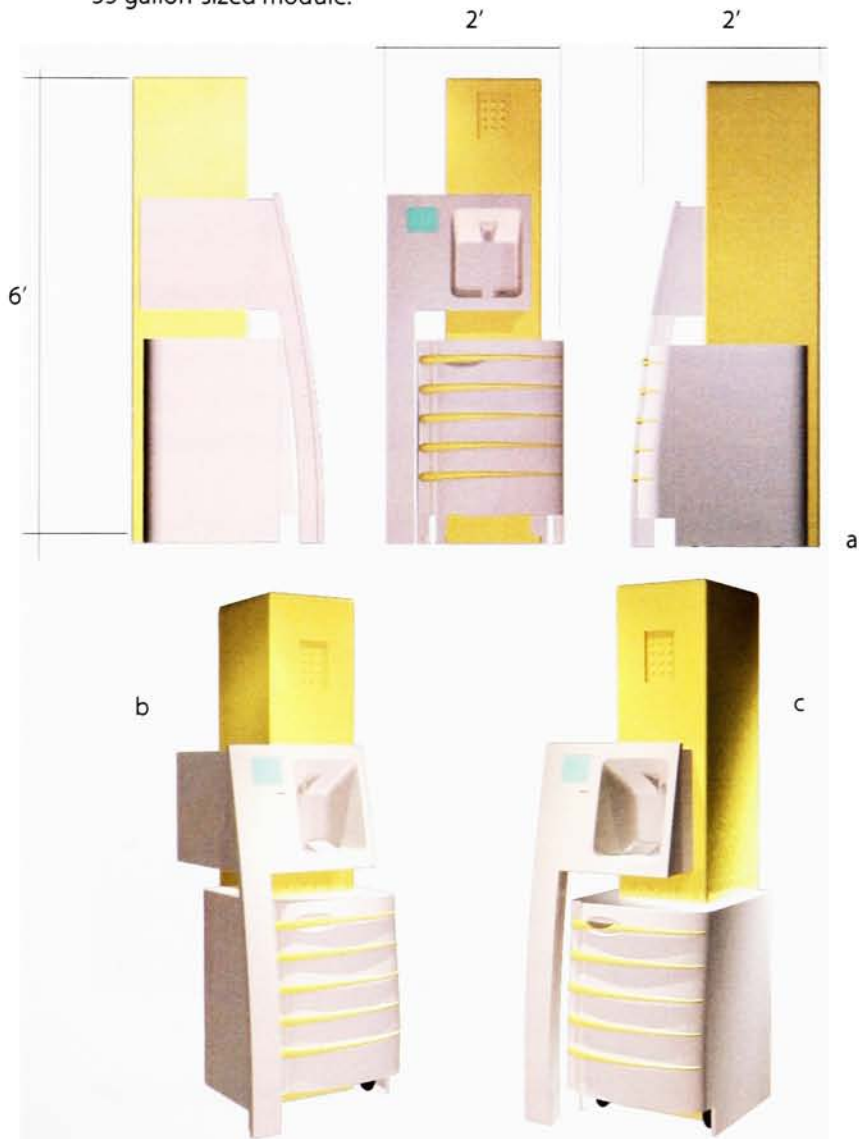

Fig. 48. Kiosk design

The lower reservoir is used to hold the 55 gallon-sized detergent module. Once the module is wheeled in, instead of pumping detergent directly from the module to the filling chamber, the detergent will be pumped up to the upper reservoir. The upper reservoir releases detergent via gravity down to the filling chamber to reduce bubbles.

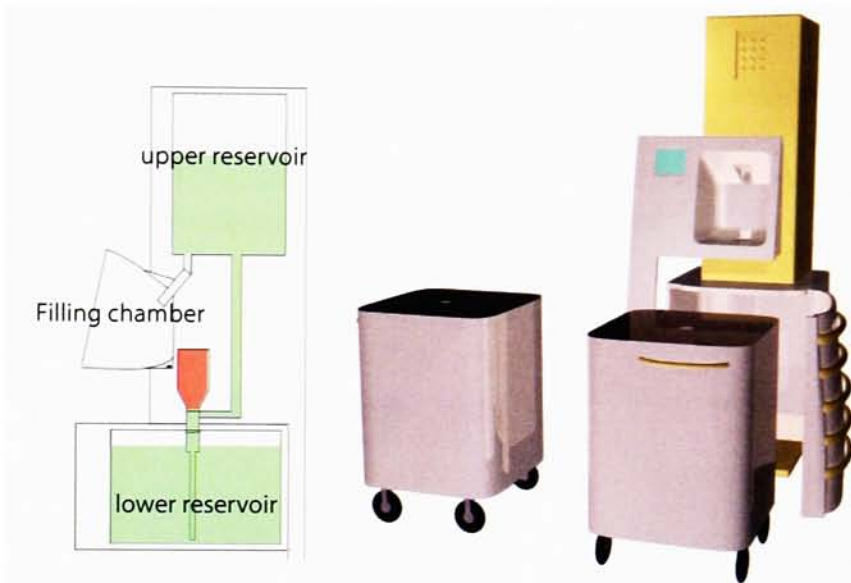

Fig.49. Kiosk's part

Fig.50. A 55 gallon-sized module

The filling chamber and the interface are two parts that customers will interact with. Customers will bring the bottle in and follow the directions on the screen to fill up the bottle.

There is a fail-safe mechanism inside the filling chamber that is used to prevent detergent from spilling. If users place the bottle correctly, it will push a small button in the filling chamber. Then, the machine will move the nozzle down automatically.

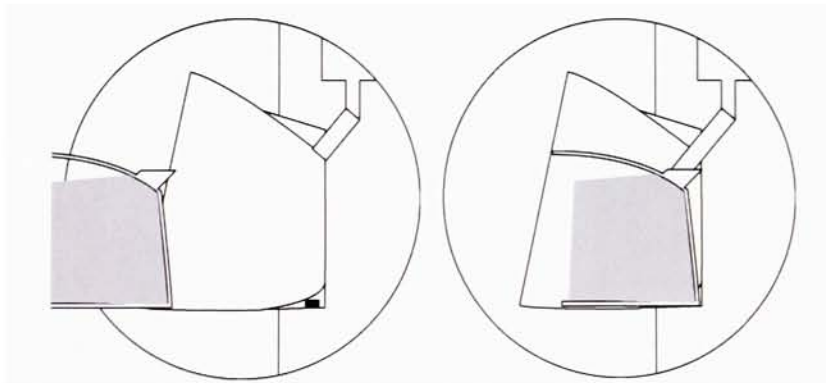

Fig.51. The detail inside the filling chamber

## Final design: Interface design

The main goal of the interface design is to communicate clearly with users. A large font size with a white background was selected, and clean and clear composition was laid out. G-Laundro is the commercial name I created to give the refill system an identity.

The refill process is as follows:

1. Place the bottle in the kiosk.



Fig. 52. Interface design

2. The machine moves the nozzle down to the bottle.



Fig. 53. Interface design

3. If the bottle isn't placed correctly, the machine will ask user to reposition the bottle.

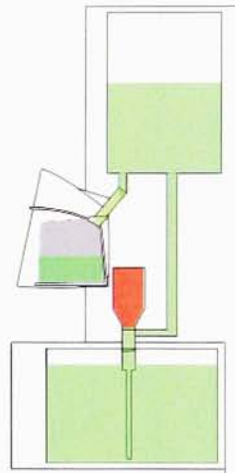

Fig. 54. Interface design

4. Once the bottle is placed correctly, detergent is released from the upper reservoir.



Fig. 55. Interface design



5. After refilling, customers may remove the bottle.



Fig. 56. Interface design

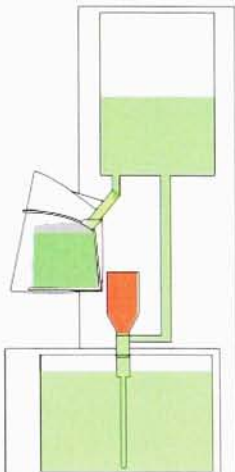

6. The machine will print a coupon with a barcode.



Fig. 57. Interface design

7. The machine shows a message asking customers to check out with the printed coupon to get a discount.



Fig. 58. Interface design

## Conclusion

The intention of this thesis is to create an effective refill system for laundry detergent that could reduce the solid waste in the landfill. The goal is to make the refill process so convenient that users do not feel that they have to do extra work or waste their time in the process. From a business perspective, the system needs to be cost-effective and shelf space saving.

Research on the refill process was done in order to anticipate problems that could occur in the real situation. Questionnaires were given out to 20 people in order to gather users' opinions about what are the encouraging and discouraging factors in the refill process. Three different types of products and market sizes were used as case studies in order to see the project's feasibility. Case studies were also used as a demonstration of what has been successful in the past.

All information was analyzed and used as criteria for designing the most effective method that fits users' lifestyle and provide the most convenient solution for users.

The final system is a simple refill process. The bottle design is convenient for the users. It is collapsible, which makes it easy to carry back for refilling. It also does not neglect the basic function of a good container such as being easy to pour and being stackable. The kiosk and its module do not require extra labor costs to fill up the machine. The interface design makes it easy for users to follow the instructions.

My questions after finishing the final design are: will people use the system to refill, how many people are willing to do it, will it only be used in a green retail store or in a nation-wide grocery store such as Walmart. These are unanswered questions that need to be pursued after the system is being used.

## Bibliography

"Householder survey points way to increasing plastic bottle recycling" in *Tech talk volume 6, number 2*, June 2002.

Mackenzie, Dorothy. *Green design: design for the environment*. London: L.King, 1997

[www.informinc.org/sp3-exec.html](http://www.informinc.org/sp3-exec.html)  
[September 28, 2002]

[www.mindfully.org/plastic/PET-recycling1990-2000.htm](http://www.mindfully.org/plastic/PET-recycling1990-2000.htm)  
[October 2, 2002]

Restore website. [www.restoreproducts.com](http://www.restoreproducts.com)

Culligan website. [www.culligan.com](http://www.culligan.com)