

Rochester Institute of Technology

## RIT Digital Institutional Repository

---

Theses

---

2-1-2012

### Create your own car: a motion graphic demo of a new game

Peng Peng

Follow this and additional works at: <https://repository.rit.edu/theses>

---

#### Recommended Citation

Peng, Peng, "Create your own car: a motion graphic demo of a new game" (2012). Thesis. Rochester Institute of Technology. Accessed from

This Thesis is brought to you for free and open access by the RIT Libraries. For more information, please contact [repository@rit.edu](mailto:repository@rit.edu).

# **Create Your Own Car**

**a motion graphic demo of a new game**

Thesis Documentation for Master of Fine Arts Degree

Rochester Institute of Technology

CIAS Computer Graphics Design

Peng Peng

---

# Thesis Documentation for the Master of Fine Arts Degree

Rochester Institute of Technology  
College of Imaging Arts and Sciences  
School of Design  
Graduate Computer Graphic Design

---

**Title:** Create Your Own Car: a motion graphic demo of a new game

**Submitted by:** Peng Peng

**Date:** February 01, 2012

## Thesis Committee Approval:

**Chief Adviser:** Dan DeLuna, Associate Professor, Computer Graphic Design

\_\_\_\_\_

**Associate Adviser:** Marla Schweppe, Professor, Computer Graphic Design

\_\_\_\_\_

**Associate Adviser:** Chris Jackson, Associate Professor, Computer Graphic Design

\_\_\_\_\_

## School of Design Administrative Chair Approval:

**Administrative Chair, School of Design:** Patti Lachance

\_\_\_\_\_

---

Thesis Title: Create Your Own Car: a motion graphic demo of a new game

By: Peng Peng

Date: February 01, 2012

---

## **Contents**

1. Abstract
2. Problem Statement
3. Documentation
4. Bibliography
5. Appendix I: Software and Hardware Requirements
6. Appendix II: Customer Survey
7. Appendix III: Workprocess
8. Appendix IV: Thesis Proposal

---

Thesis Title: Create Your Own Car: a motion graphic demo of a new game

By: Peng Peng

Date: February 01, 2012

---

## Abstract

The project *Create Your Own Car* explores a realistic style of motion graphics through the car-assembling process using both 2D and 3D visual effects to popularize a new racing game to attract more people. The motion graphics illustrate the game features in an interactive game with personalized cars. This project includes two parts: one is the design of personalized vehicles, and the other is the animation stage, which presents the final motion graphics piece. The first stage explores two classic types of vehicles: the muscle car and the sports car. The main focus is on both the different interior constructions and the exterior shape designs. Therefore, this project includes the program Maya for modeling, rendering and animation. The second stage explores an animation which is based on an executable car-assembling motion. The final presentation is a short motion graphic in a realistic style for a racing game teaser trailer (figure 01).



Figure 01: Create Your Own Car

---

Thesis Title: Create Your Own Car: a motion graphic demo of a new game

By: Peng Peng

Date: February 01, 2012

---

## **Problem Statement**

Different from other game teaser trailers, I am going to be elaborating on the game's feature which allows users to interact and personalize their cars. Players can choose different basic parts (such as engine, tires, steering wheel, etc.), and assemble their own dream cars.

My problem statement is: how do I use a realistic style of motion graphic for a racing game teaser trailer to attract more players? And as a designer, how could I popularize this racing game through this motion graphic?

In my project, I will create a motion graphic piece for a racing game through car-assembling process using both 2D and 3D visual effects. Compared with other teaser trailer racing games, mine focuses on the personalized interior construction and exterior design through the motion graphic, instead of realistic racing game visuals.

---

Thesis Title: Create Your Own Car: a motion graphic demo of a new game

By: Peng Peng

Date: February 01, 2012

---

## Documentation

### Design Consideration

#### Teaser trailer analysis

Today, with the wave of racing game popularity, a large number of relevant teaser trailers are created in its wake, which focus mainly on the visuals of the game for an enhancement of realism. Almost all of these commercials use the game appearance as raw material, through post editing with camera language, to display the visuals of those games. In this case, I think video-game players are always confused at the choice of these video games because they can only see the visual effects of the games, rather than the features.

Initially, the end title sequence of *Iron Man* is at the core of what inspired my thesis project. In that motion graphics piece, it illustrates the end credit through *Iron Man*-assembling process using 2D cartoon rendering style to attract people. When I saw the end credit, I was working on an independent study - concept vehicle design. The concept vehicle was assembled by numerous basic parts, such as tires, steering-wheel, dashboard, and etc. I thought that why not using this assembling animation style to design a motion graphics piece as a teaser trailer to promote a racing game? In this way, my thesis project will be different from other racing game teaser trailers. It will focus on communicating the game's feature that allows users to interact and customize their cars.

Because the thesis project is designed to popularize a realistic racing game as a teaser trailer,

---

Thesis Title: Create Your Own Car: a motion graphic demo of a new game

By: Peng Peng

Date: February 01, 2012

---

I thought this project should also illustrate visuals of the realism racing game. Therefore, realistic rendering style of this teaser trailer is a good way to attract more players.

### **Color consideration**

In my thesis project, red and blue are majority colors in motion graphics, because they are two classic and popular colors in American culture. They come from the American flag, which can inspire people's patriotism. Therefore, I decided to apply blue for the muscle car and red for the sports car, which is a good way to attract audiences. In terms of background, I chose white as the key tone and emphasized the high contrast between the background and the personalized cars. In this sense, the motion graphics will take on clear visuals.

### **Typeface research**

At the beginning of my research, I planned to design a new font for typography of motion graphics. When I talked this idea to my chief adviser Daniel DeLuna, he had different opinion. He explained to me that within the design field, there are several classic fonts of typography which are classic typefaces likely to be popular in the future. Therefore, I finally chose Helvetica for the typeface of motion graphics. Helvetica is one of the most widely used sans-serif typefaces in the world and it is a popular choice for commercial wordmarks.

### **Vehicle design**

For my thesis project, I decided to reference two classic vehicle styles for exterior shape design, the muscle car and the sports car.



---

Thesis Title: Create Your Own Car: a motion graphic demo of a new game

By: Peng Peng

Date: February 01, 2012

---

“Muscle car is a term used to refer to a variety of high-performance automobiles” (Koch, Jeff).

The *Merriam-Webster dictionary* defines muscle cars as “any of a group of American-made 2-door sports coupes with powerful engines designed for high-performance driving” (“Muscle Car”). “A sports car (or sportscar or sport car) is a small, usually two seat, two door automobile designed for high speed driving and maneuverability. Sports cars have been either spartan or luxurious, but good handling, minimum weight, and high performance are requisite” (Csere, Csaba and Swan, Tony, “Sports Car”).

Interior construction of the cars is the essential part in my thesis project. During my research I ordered a professional vehicle magazine *Autoweek* as my reference. Within several weeks of my researching and referencing, I found out that there are two differences between professional racing cars and regular cars: engine location and Nitrous Oxide System. For the purpose of more powerful acceleration, the engine of racing car is usually located in the back of the car rather than the front. In addition, the racing cars have Nitrous Oxide System, which is used to increase an internal combustion engine’s power output by allowing more fuel to be burned.

### **Animation consideration**

To achieve the animation of car-assembling, I planned to create different kinds of vehicle components, including screws, gears and pistons, which are basic elements for the motion graphic. Then they were integrated into different parts (such as engine, tires, steering wheel, etc.) through the movement of translation, rotation and scale.

---

Thesis Title: Create Your Own Car: a motion graphic demo of a new game

By: Peng Peng

Date: February 01, 2012

---

Also I displayed different designs for the same parts. An example is different models of engines (figure 02), different types of tires, different seats. Then these parts were integrated into an entire car in this assembling process. In this way, the motion graphic explores the game features: an interactive game and personalized cars.

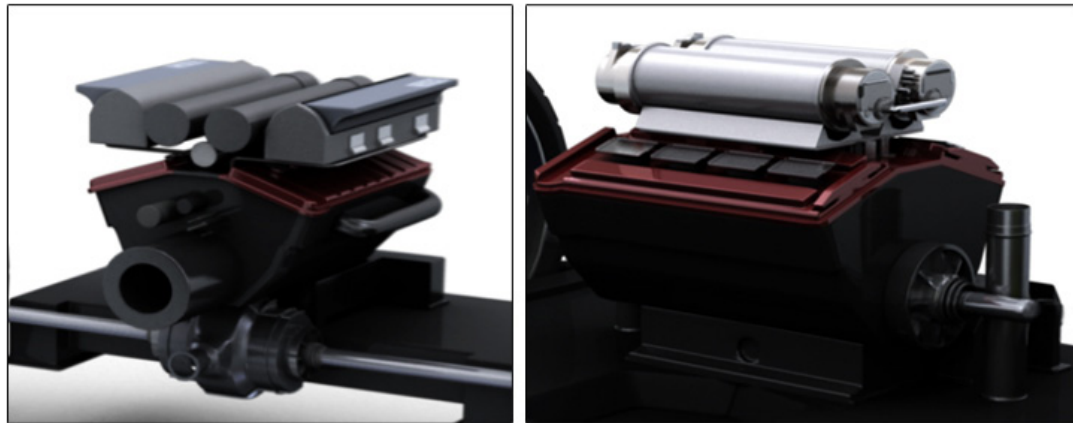

Figure 02: different models of engines

Meanwhile, I payed great attention to whether the picture compositing is balanced (figure 03): if the object is in the direction of left and right, or up and down, this maintains basic picture compositing balance . In the aspect of design theory, I explored shot bridging, color co-ordination, texture applications and animation principles.

---

Thesis Title: Create Your Own Car: a motion graphic demo of a new game

By: Peng Peng

Date: February 01, 2012

---

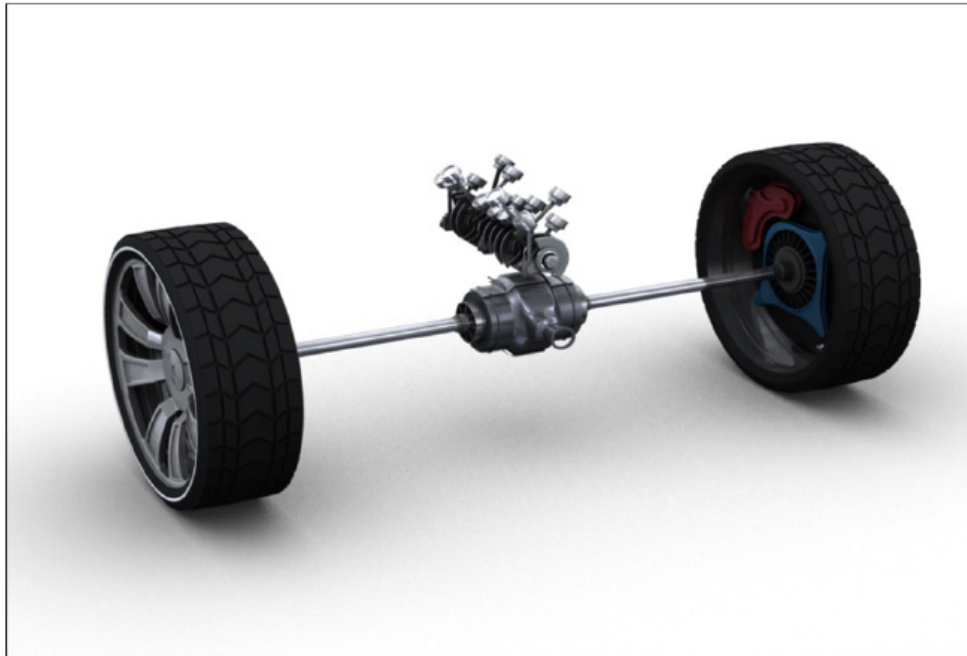

Figure 03: picture compositing

The background music has a strong beat and fast pace in order to draw audience's attention. I expect that people will be impressed not only by the visual effects but also the audio effects through this motion graphic. The music is composed with drum sound, electric sound, etc.

---

Thesis Title: Create Your Own Car: a motion graphic demo of a new game

By: Peng Peng

Date: February 01, 2012

---

## **Process**

### **Storyboard**

When the basic concept of the project was determined, the actual work started. The first step was to create the storyboard. It was displayed in sequence for the purpose of previewing the motion graphics.

### **Background music**

Before the animatic stage started, Daniel suggested to me a good way for saving time. At first, I found a temporary music as a reference music for the timing of the animatic. At the same time, I enlisted my friend, Xiaoyu Liu who studied contemporary music in China to help me. The new music has the same pace and the same beat as the temporary music. When the new music was finished, I used the new one to replace the temporary one, and it matched my animatic perfectly.

### **Animatic**

After the final storyboard was decided, my associate adviser Marla Schweppe suggested to me to create an animatic, because it gives a better idea of how the scene will look and feel with motion and timing. In this step, I tried several versions, 3D typography version, game interface version, and commercial typography version.

In 3D typography version (figure 04), I used 3D fonts as a design element to explain all of the basic vehicle parts. However, Daniel thought the audiences would be misunderstanding this version because of the content of the typography, which explained the basic vehicle parts, rather

---

Thesis Title: Create Your Own Car: a motion graphic demo of a new game

By: Peng Peng

Date: February 01, 2012

---

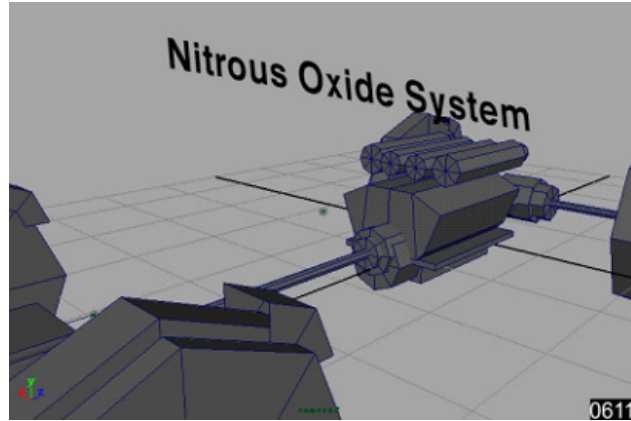

Figure 04: 3D typography version

than the racing game features. In doing so the audiences will be confused about the purpose of this motion graphics. They probably would think this motion graphics was designed for real car rather than a racing game.

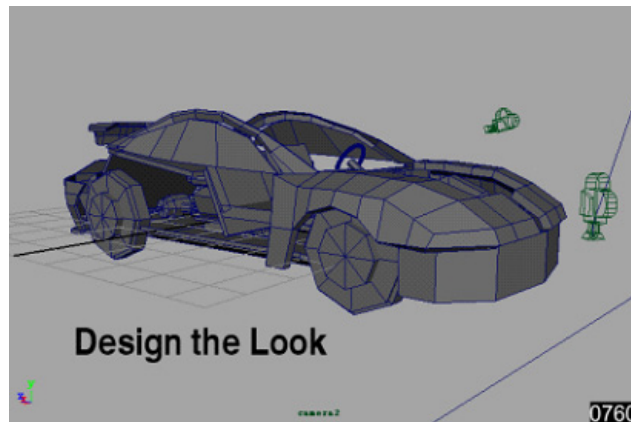

Figure 05: Game interface version

The game interface version (figure 05) was the second version I created. In order to let the audiences receive the purpose of this motion graphics, I designed a game interface and applied it

---

Thesis Title: Create Your Own Car: a motion graphic demo of a new game

By: Peng Peng

Date: February 01, 2012

---

to the motion graphics. However, there was a conflict between the interface and the motion graphics visuals. In my opinion, the information on the interface was really intense in the scene, and the audiences would focus on the interface rather than the motion graphics.

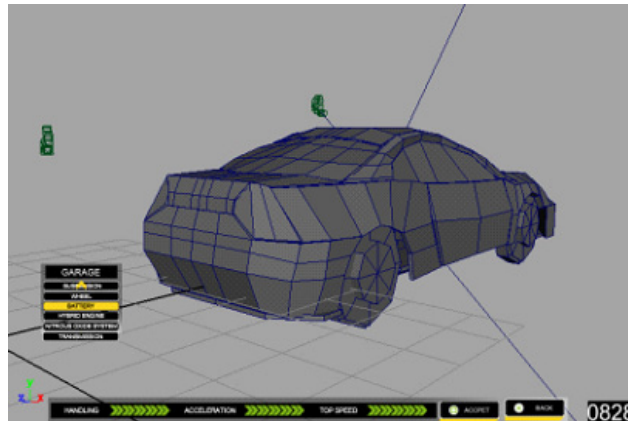

Figure 06: Commercial typography version

After that, I decided to move on to the commercial typography version (figure 06). In this version, I used 2D fonts for the typography, because 2D fonts are more clear than 3D fonts. In addition, Marla helped me to work on the content of typography. She suggested that I use key words in a simple but powerful way. “The simple word is strong and powerful” she explained. In this way, the audiences will get the purpose of this motion graphics, and the typography will match the visuals perfectly.

---

Thesis Title: Create Your Own Car: a motion graphic demo of a new game

By: Peng Peng

Date: February 01, 2012

---

## Modeling

The first action was to research current modeling procedures in the computer graphics industry. My reference magazine *Autoweek* was a good start, but to apply realistic 3D vehicle models in Maya the resources needed to be expanded upon. There are a lot of vehicle models at website *Creativecrash*, which helped me to understand how a 3D vehicle model in Maya is integrated by different hard surfaces. In addition, I noticed how the edge loops effect the shape of hard surfaces (figure 07).

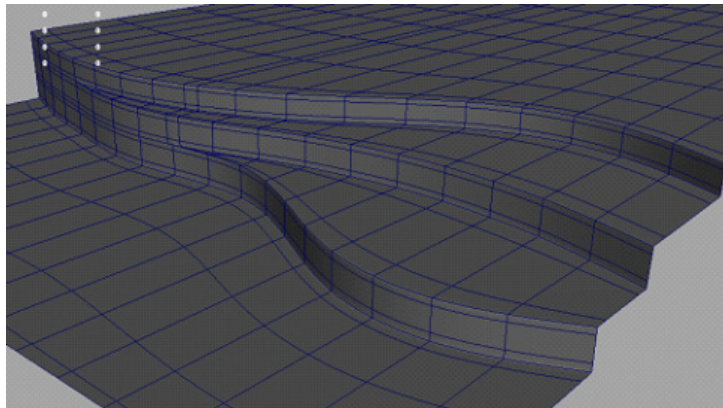

Figure 07: The edge loops effect the sharp of surface

I started modeling a vehicle with low polygons. In my opinion, polygon modeling is the most flexible method the program has to offer. The default polygon cube was used for the basic shape, then it was deformed through different functions in Maya, such as extrude, merge, combine, etc. In order to get correct edge loops, I adjusted the position of the vertices, edges or faces as well at the same time. The key point in this step was to create the polygon models using a minimal amount of vertices, which keep edge loops clean and economical (figure 08).

---

Thesis Title: Create Your Own Car: a motion graphic demo of a new game

By: Peng Peng

Date: February 01, 2012

---

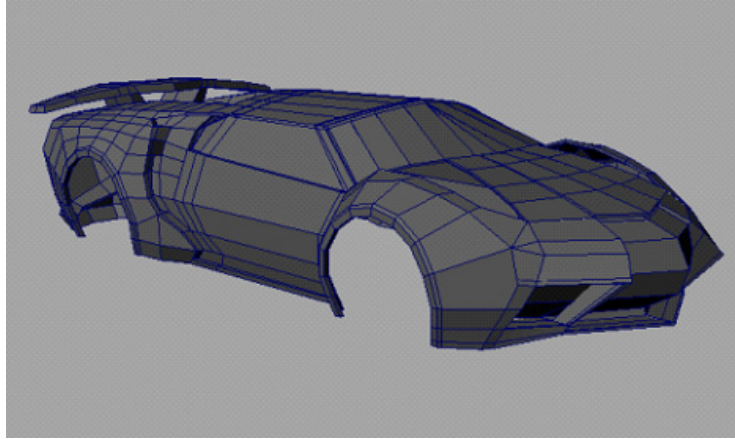

Figure 08: low quality models

Usually, layout UVs are the most complicated work for me in 3D creative work process in the past, because I am used to finish high quality models first, then start to layout UVs. In order to get expected texture drawing, I have to layout numerous UVs and keep them as much the same size and shape as possible. However, I started to layout UVs with low polygon models in my thesis process this time. At the modeling step, I used the least amount of vertexes to achieve the basic geometries, so that layout UVs were much easier and quicker than before. The texture “checker” was applied for each geometry to check UVs (figure 09).



---

Thesis Title: Create Your Own Car: a motion graphic demo of a new game

By: Peng Peng

Date: February 01, 2012

---

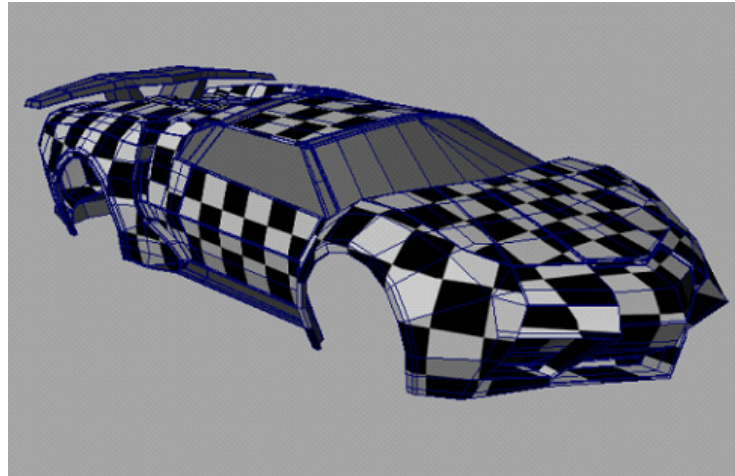

Figure 09: UV checker

Next, the low quality models needed to be improved to high quality models for realistic visuals (figure 10). This step was accomplished by incorporating soft and hard edges to give contrast to the surfaces. Also, I rechecked UVs and corrected them, because some UVs were changed while some edge loops were changing.

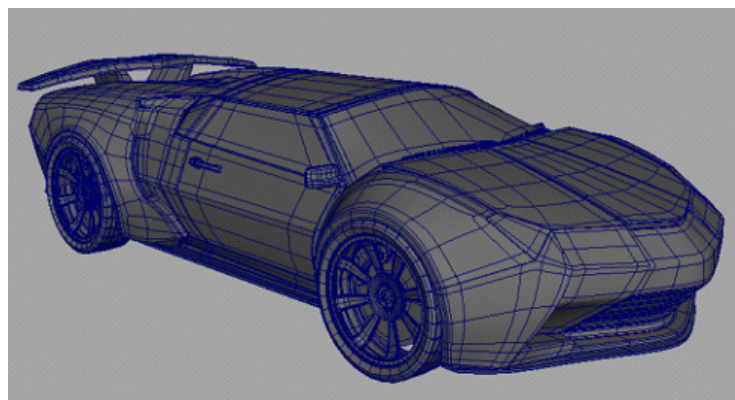

Figure 10: High quality models

---

Thesis Title: Create Your Own Car: a motion graphic demo of a new game

By: Peng Peng

Date: February 01, 2012

---

### **Lighting and shading**

The most important area of technical development for me was learning the Mental Ray in relation to lighting and shading in the program Maya. The Mental Ray official website defines Mental Ray as “a high performance, photorealistic rendering software which produces images of unsurpassed realism from computer-aided design and digital content creation data, by relying on patented and proprietary ray tracing algorithms” (*mentalimages-Webster Online*). Because of its production-quality rendering, I chose it instead of default Maya rendering.

To achieve the realistic visuals, the lighting was a good start. In order to get the basic lighting, a HDR (High Dynamic Range) image was applied to a basic polygon sphere in the scene for global illumination and reflection of the environment. In terms of background, I turned off the attribute of the sphere “primary visibility” as well, because the background should be white for final visuals. Next, several area lights were created to only illuminate the specular highlight for the cars.

After that, I started working on Mental Ray architectural materials. Mia-material-x was used as a basic shader for the majority of shaders, because of very high level controls, which are able to adjust a number of samples on primary bases. Dielectric-material was applied for glasses because of its high quality of reflection and refraction.

### **Animation**

In my thesis, the animation was divided into two parts: the animation of engine pistons and the animation of cameras and geometries.

---

Thesis Title: Create Your Own Car: a motion graphic demo of a new game

By: Peng Peng

Date: February 01, 2012

---

The entire animation was began with the animation of engine pistons. In order to achieve the animation realistically, the first action was to research reference videos from the Internet.

The video *4 cycle internal combustion engine* from *YouTube* was a good start. Within several days of my researching and referencing, I understood the exact motion of those pistons. Then I started with the actual work in the program Maya.

The function constraints in Maya was used to control different parts of engine pistons. With constraints, I drove the position, rotation, and scale of one object with the transformation settings of another object. Further, I imposed specific limits on objects and automated animation process.

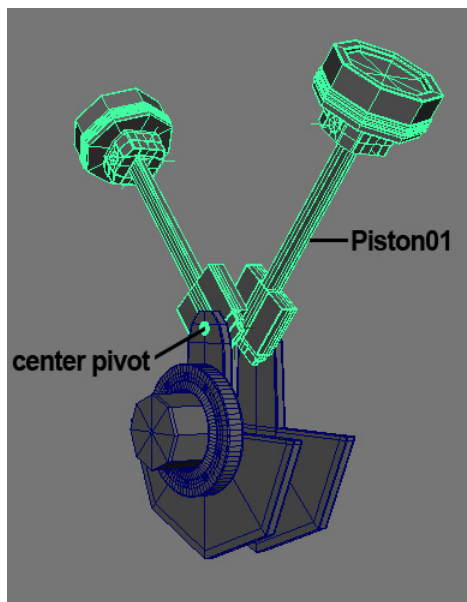

Figure 11: Piston01

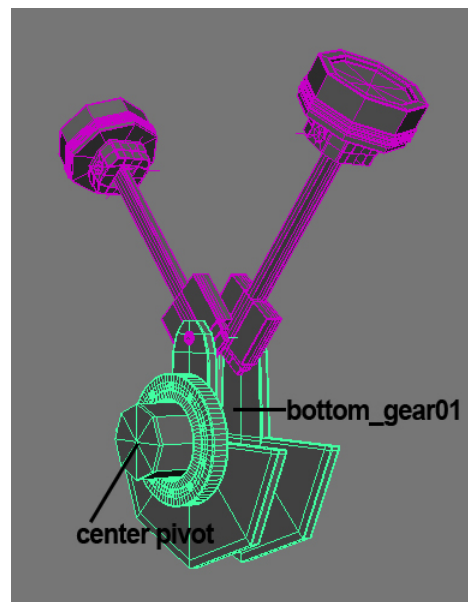

Figure 12: bottom\_gear01

The first step for constraint setting was to organize all components (pistons, gears and support axes). I put each component in a suitable position. Then all their transformations were frozen to

---

Thesis Title: Create Your Own Car: a motion graphic demo of a new game

By: Peng Peng

Date: February 01, 2012

---

the origin. I grouped the top part including the piston lids and the support axles to one object and renamed it Piston01. Then I reset the center pivot (figure 11). The same process for the bottom part as well, and I renamed it bottom\_gear01 (figure 12).

The next step was to set up the point constraint and the aim constraint in the program Maya. "The point constraint is undoable, queryable, and editable. Constrain an object's position to the position of the target object or to the average position of a number of targets" (Autodesk, "Point Constraint"). I used the point constraint to connect bottom\_gear01 and Piston01. The result was that the piston01 would follow the movement of the bottom\_gear01. Next, I used the aim constraint to drive the rotation of bottom\_gear01 with the rotation of Piston01. "The aim constraint constrains an objects's orientation to point at a target object or the average position of a number of targets" (Autodesk, "Aim Constraint"). After that, the orientation of Piston01 would point at the position of bottom\_gear01 all the time. The same constraint settings were used to drive the piston lid with the support axle in the process. Therefore, the piston lid in Piston01 would move and follow the support axle automatically, and the support axle would follow and rotate in the correct manner as real engine pistons when the bottom\_gear01 is rotated.

To sum up, I used constraints to simplify the animation of engine pistons, and the entire piston system will be driven automatically when the bottom gear is rotated (figure 13).

---

Thesis Title: Create Your Own Car: a motion graphic demo of a new game

By: Peng Peng

Date: February 01, 2012

---

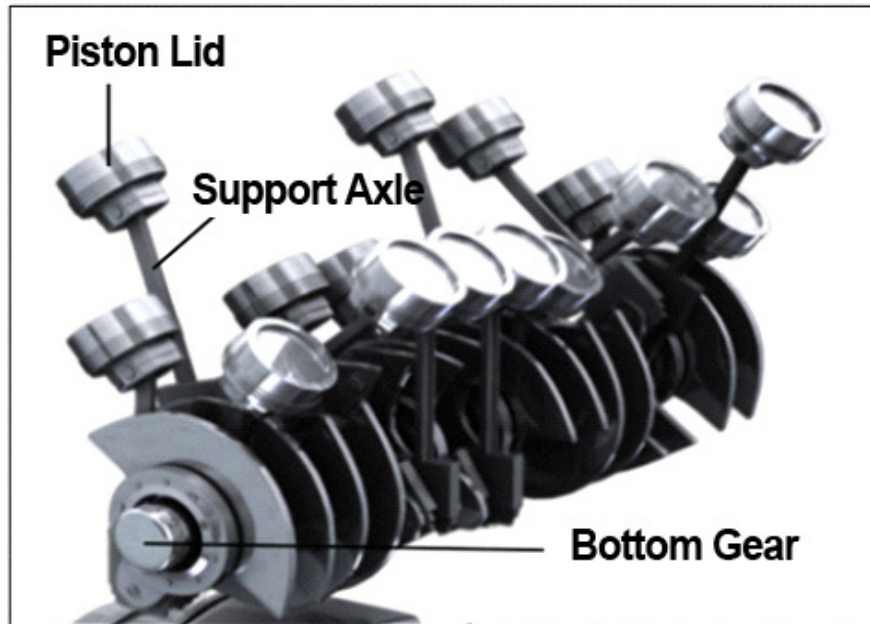

Figure 13: engine pistons

The next step was to set up an animation scene. I created a new animation scene as a referenced parent scene, and loaded the scene of cars as referenced child scenes in Maya. Then, I can animate all related objects (such as camera, geometries, etc.) in a referenced parent scene and modify the models in the referenced child scene. The benefit was that if the the scene of cars was modified, then the models of the animation scene will be changed coincidentally, which will not effect the animation in the referenced parent scene.

After that, I set up the cameras in the animation scene. I used a 70mm focal length camera to give the scene more visual depth to help people focus more on vehicles (figure 14).

---

Thesis Title: Create Your Own Car: a motion graphic demo of a new game

By: Peng Peng

Date: February 01, 2012

---

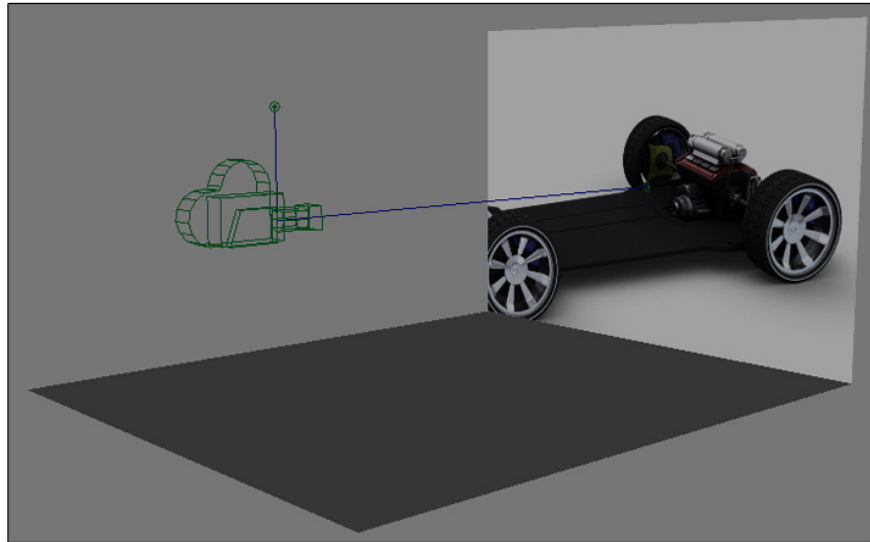

Figure 14: the camera was perpendicular to the background

Referencing the animatic, the cameras and geometries were animated following the pace of the background music. I used flat tangents for easy in and easy out camera animation in Maya's graph editor. In order to get smooth transition, I applied camera language and design theory to balance the visuals in the mean time. For instance, the camera moved from one close-up geometry to an extreme close-up in the scene. Then the geometry would be in the center of the visual and block the audiences' view. At this time, I changed the original scene to a new one, and the geometry moved from the center of the visual to the other side. The new scene would show up to audiences smoothly and naturally. The geometries were animated using translate, scale, and rotate functions in Maya. For the geometries' appearance, I scaled them to 0 first, which means the geometries would be invisible from the scene. Then I keyed them at that frame. After a few

---

Thesis Title: Create Your Own Car: a motion graphic demo of a new game

By: Peng Peng

Date: February 01, 2012

---

frames, I scaled them to 1, which means the geometries would be scaled to original size, as I keyed them at that frame. After that, the geometries would appear in the scene in a smooth and natural way. For assembling animation, I thought the geometries should combine together in an active and dynamic way. Therefore, I paid attention to the animation principles to achieve this endeavor, such as follow through and secondary animation.

### **Rendering**

I used two render passes for final rendering. The first pass is a beauty layer (figure 15). In this layer, all information related colors were illustrated except shadows, such as diffuse color, reflection, glossiness, etc.

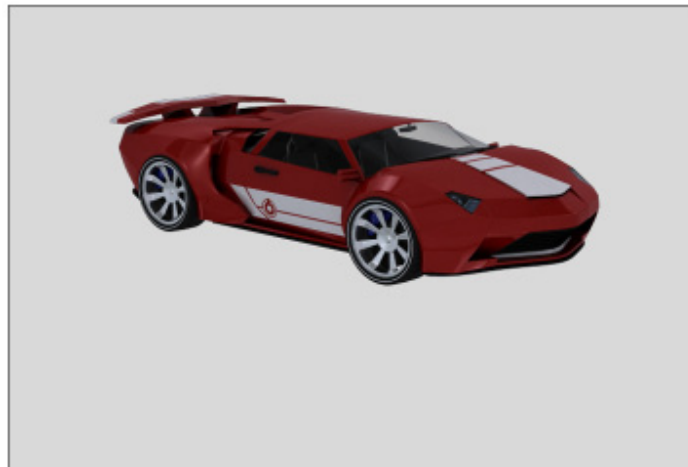

Figure 15: beauty layer

The second layer is ambient occlusion (figure 16). “It is a shading method which helps adding realism to local reflection models by taking into account attenuation of light due to occlusion”

---

Thesis Title: Create Your Own Car: a motion graphic demo of a new game

By: Peng Peng

Date: February 01, 2012

---

(Autodesk, "Ambient Occlusion"). The background and the shadows were demonstrated in this layer as well.

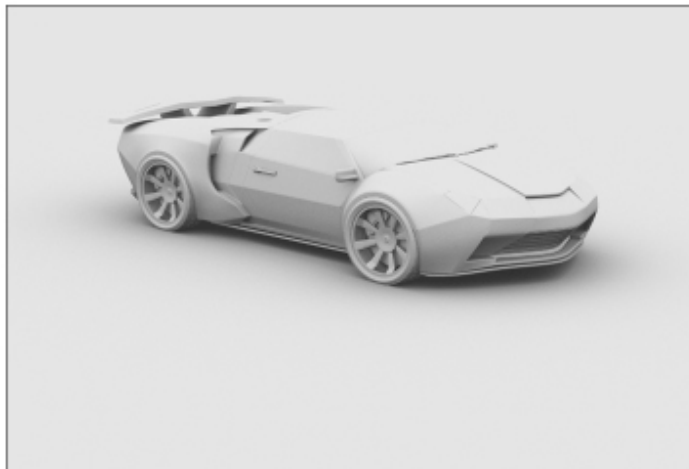

Figure 16: ambient occlusion layer

In final rendering, I did not render directly as a quicktime movie, but instead, rendered out the beauty layer and ambient occlusion layer as two image sequences. This technique will prevent re-rendering the entire animation in case of accidental issues or design reconsiderations. For example, if the computer is corrupted, I can continue rendering on whatever frame it stopped on.

### **Compositing and special effects**

In order to achieve realistic visuals, the image sequences of beauty layer and ambient occlusion layer were composited together using overlay mode in the program After Effects (figure 17). The advantage was that I am able to adjust the beauty layer and ambient occlusion layer individually to get experted visuals.



---

Thesis Title: Create Your Own Car: a motion graphic demo of a new game

By: Peng Peng

Date: February 01, 2012

---

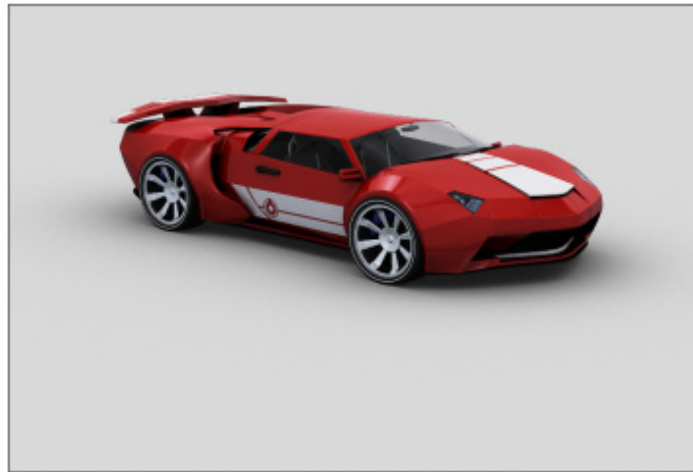

Figure 17: overlay mode

In the mean time, the final background music was composed by Xiaoyu, which matched my animation perfectly. He used a relative pace and beat with contemporary music.

In addition, my associate adviser, Chris Jackson, helped me develop a typographic composition. He pointed out several relevant problems, such as how to build the relation between animation and typography, how to make the connection to typography, and how to use capital words to emphasize importance, etc.

For instance, the word “DESIGN” is capital to emphasize the purpose of the motion graphics: personalized cars and an interactive game. On the other hand, there is an invisible oblique line between the N of “DESIGN” and the Y of “Your”, which makes indirect connections to typography, so that “DESIGN” and “Your Own” will be integrated together (figure 18).

---

Thesis Title: Create Your Own Car: a motion graphic demo of a new game

By: Peng Peng

Date: February 01, 2012

---



Figure 18: typographic composition

Lastly, I added some special effects to the motion graphics in After Effects (figure 19).



Figure 19: typographic composition

I adjusted the input levels of white color correction to enhance high contrast between the background and the vehicles. In order to get dynamic and realistic motion, I added CC force motion blur to the animation. Consequently, the final version with special effects are more clear and

---

Thesis Title: Create Your Own Car: a motion graphic demo of a new game

By: Peng Peng

Date: February 01, 2012

---

more dynamic than the original one.

---

Thesis Title: Create Your Own Car: a motion graphic demo of a new game

By: Peng Peng

Date: February 01, 2012

---

## Conclusion

In my opinion, this project was a success with all expected objectives being accomplished.

High quality models were created with realistic style. Global illumination and reflection of environment developed using a HDR image, and Mia-material-x shaders were created to enhance realism. 2D typography was designed to explain the purpose of motion graphics. To sum up, the final product actually achieved my own creative and technical expectations through extensive research and problem solving.

The most important area of technical development for me was learning Mental Ray in relation to lighting and shading in Maya. Because the most difficult technical problem in this project was creating realistic visuals.

At last, the chief area of professional growth for me was the design considerations for motion graphics. In my case, I realized that I need to design this project from an audiences' perspective, because the objective of this project is to popularize a new racing game to more people. Therefore I emphasized a lot of popular elements for this project, such as attractive colors (red and blue), two classic kinds of vehicles (music car and sports car), classic typeface, etc. Overall I think I grew both personally and professionally through the development of this project. I understand even more about myself and my future role in computer graphic design.

---

Thesis Title: Create Your Own Car: a motion graphic demo of a new game

By: Peng Peng

Date: February 01, 2012

---

## Bibliography

### Source books:

Koch, Jeff. *The First Muscle Car: Older Than You*. Hemmings muscle Machines, October 2004. Print.

Csere, Csaba and Swan, Tony. *10 Best Cars: Best Luxury Sports Car*. Car and Driver, October 2006. Print.

Autoweek press. *Autoweek*. Autoweek, March 1, 2011. Print.

Happian-Smith, Julian. *Introduction to Modern Vehicle Design*. July, 2000. Print.

Adler, Dennis. *The Art of the Automobile: The 100 Greatest Cars*. William Morrow. 1 edition. May 3, 2000. Print.

Spencer, Drate; Robbins, David and Salavetz, Judith. *Motion by Design*. Laurence King; Har/DVD edition. December 14, 2006. Print.

Onedotzero. *Motion Blur: 1 – The OneDotZero Book*. Laurence King; Pap/DVD edition. July 13, 2006. Print.

Onedotzero. *Motion Blur: 2 - Multidimensional Moving Imagemakers*. Laurence King; Pap/DVD edition. November 8, 2007. Print.

Hirschfeld, Julie; Barth, Stefanie; Hall, Peter and Codrington, Andrea. *Pause: 59 minutes of motion graphics*. Universe Publishing; Presumed First edition. May 19, 2000. Print.

Autodesk Maya Press. *Learning Autodesk Maya 2009: official Autodesk training guide-The modeling & animation handbook*. 2009. Print.

### Online Documents:

Muscle Car. Merriam-Webster <<http://www.merriam-webster.com/dictionary/muscle%20car>>. n.d.

Sports car. Merriam-Webster <<http://www.merriam-webster.com/dictionary/sports%20car>>. n.d.

---

Thesis Title: Create Your Own Car: a motion graphic demo of a new game

By: Peng Peng

Date: February 01, 2012

---

Mentalimages <<http://www.mentalimages.com/products/mental-ray.html>>. Mentalimages. n.d.

Monkeyseevideos <<http://www.youtube.com/watch?v=wRIKJ6Av5zo>>. *4 cycle internal combustion engine*. Youtube Web, September 26, 2008.

The Gnomon Workshop <<http://www.thegnomonworkshop.com/store/product/217/UV-Mapping-for-Games>>. *Gnomon UV Mapping for Games*. Gnomon Web, n.d.

The Gnomon Workshop <<http://www.thegnomonworkshop.com/store/product/427/Hard-Surface-Texture-Painting>>. *Gnomon Hard Surface Texture Painting Vehicle Texture Painting*. Gnomon Web, n.d.

Green, Kyle. <<http://www.digitaltutors.com/11/training.php?pid=594>>. *RealFlow and Maya Integration*. Digital-Tutors Web, November 14, 2005.

Green, Kyle. <<http://www.digitaltutors.com/11/training.php?pid=3575>>. *Render Passes In Maya 2009*. Digital-Tutors Web, November 4, 2008.

Green, Kyle. <<http://www.digitaltutors.com/11/training.php?pid=134>>. *Rendering RealFlow Meshes in Maya*. Digital-Tutors Web, August 3, 2009.

Green, Kyle. <<http://www.digitaltutors.com/11/training.php?pid=135>>. *Digital Tutors Introduction to mental ray in Maya 2012*. Digital-Tutors Web, August 2, 2011.

Marshall, Justin. <<http://www.digitaltutors.com/11/training.php?pid=2691>>. *Digital Tutors Maya Modeling Techniques: Interiors*. Digital-Tutors Web, March 15, 2007.

Marshall, Justin. <<http://www.digitaltutors.com/11/training.php?pid=3403>>. *Creating Cartoon Vehicles in Maya*. Digital-Tutors Web, October 15, 2007.

---

Thesis Title: Create Your Own Car: a motion graphic demo of a new game

By: Peng Peng

Date: February 01, 2012

---

## **Appendix I: Software and Hardware Requirements**

- AutoDesk Maya
- Adobe After Effects
- Adobe Photoshop

---

Thesis Title: Create Your Own Car: a motion graphic demo of a new game

By: Peng Peng

Date: February 01, 2012

---

## Appendix II: Customer Survey

### The Investigation of Potential Market from Target Audiences

- ◇ Age:
- ◇ Gender:
- ◇ Education level:
- ◇ Profession:
- ◇ Location:
- ◇ Do you like the design style of *Create Your Own Car*?  
Yes      Don't Know      No
- ◇ Does the car-assembling process illustrate the game features, which are an interactive game and personalized cars?  
Yes      Don't Know      No
- ◇ Do you think *Create Your Own Car* is able to promote a new racing game?  
Yes      Don't Know      No
- ◇ What game platform do you use?  
Playstation      X-box      Wii      other:
- ◇ Where would you like to watch *Create Your Own Car*?  
game website      television game channel      game store      All



---

Thesis Title: Create Your Own Car: a motion graphic demo of a new game

By: Peng Peng

Date: February 01, 2012

---

## Appendix II: Customer Survey

### Example of Customer Survey

◇ Age: **42**

◇ Gender: **Male**

◇ Education level: **MFA**

◇ Profession: **Associate Professor**

◇ Location: **NY**

◇ Do you like the design style of *Create Your Own Car*?

**Yes**      Don't Know      No

◇ Does the car-assembling process illustrate the game features, which are an interactive game and personalized cars?

**Yes**      Don't Know      No

◇ Do you think *Create Your Own Car* is able to promote a new racing game?

**Yes**      Don't Know      No

◇ What game platform do you use?

Playstation      X-box      Wii      other: **PC**

◇ Where would you like to watch *Create Your Own Car*?

game website      television game channel      game store      **All**

---

Thesis Title: Create Your Own Car: a motion graphic demo of a new game

By: Peng Peng

Date: February 01, 2012

---

## Appendix II: Work Process

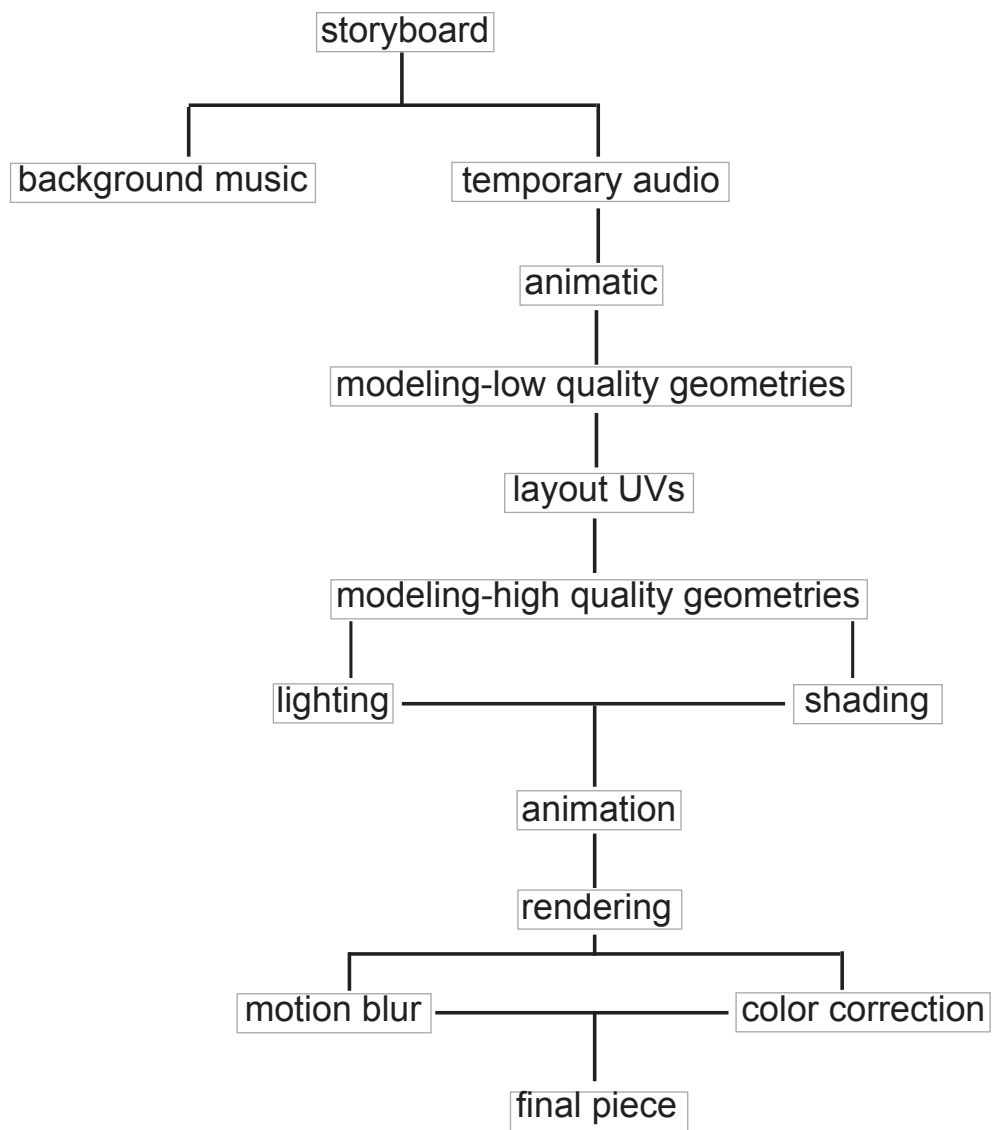

---

Thesis Title: Create Your Own Car: a motion graphic demo of a new game

By: Peng Peng

Date: February 01, 2012

---

## **Appendix III: Thesis Proposal**

# **Create Your Own Car**

**a motion graphic demo of a new game**

Thesis Proposal for Master of Fine Arts Degree

Rochester Institute of Technology

CIAS Computer Graphics Design

Peng Peng

---

Thesis Title: Create Your Own Car: a motion graphic demo of a new game

By: Peng Peng

Date: February 01, 2012

---

## Situation Analysis

Nowadays, the number of racing games is multiplying, and a large number of relative commercials are being created, which focus mainly on the visuals of the game for an enhancement of realism. Almost all of these commercials use the game appearance as raw material, through post editing with camera language, to display the visuals of those games. In this sense, videogame players are always at sea in the choice of these video games because they can only see the visual effects of the games, rather than their game features.

## Problem Statement

My problem is how do I use a realistic style of motion graphic for a racing game teaser trailer to attract more players? And as a designer, how can I popularize this racing game through this motion graphic?

I plan to design a one-minute piece of motion graphic teaser trailer to promote one racing game. I am going to focus on communicating the game's feature that allows users to interact and personalize their cars. Players can choose the different basic parts (such as engine, tires, steering wheel, etc.) to assemble their own dream cars.

In my project, I will create a motion graphic piece for a racing game through car-assembling process using both 2D and 3D visual effects. Compared with other commercial racing games, mine focuses on the personalized interior construction and exterior design through motion graphic, instead of realistic racing game visuals.

## Projection Methodology

I will create kinds of components, including screws, gears and pistons, which are basic elements for the motion graphic. Then they will be integrated into different parts (such as engine, tires, steering wheel, etc.) through the movement of translation, rotation and scale.

Also I will display different designs to the same parts. An example will be different models of engines, different types of tires, different seats, etc. Then these parts will integrate into an entire car in this assembling process. In this way, the motion graphic will illustrate game features: an interactive game and personalized cars.

I will show the motion graphics piece for audiences in a realistic style. To achieve this goal, I shot explore the high polygon models and the textures close to reality, which are the main parts of

---

Thesis Title: Create Your Own Car: a motion graphic demo of a new game

By: Peng Peng

Date: February 01, 2012

---

the motion graphic. In terms of background, I will take white as the key tone and emphasize the contrast between background and motion graphic. In this sense, the motion graphic will take on clear, positive and intense visuals. Meanwhile, I will pay great attention to whether the picture constitution is balanced: if the object is in the direction of left and right, or up and down, this maintains basically the picture constitution balance. In the aspect of design theory, I will explore shot bridging, color co-ordination, texture applications and animation principles. Meanwhile, in this motion graphic, I will use lines to attract the audiences' attention. HELVETICA (font) will be used for the audiences to explain different parts, such as batteries, hybrid engine, etc. In term of the background music, I will use or compose music in a strong beat. Also the sound effect will be used, such as the engine's sound, the sound while assembling, etc.

The motion graphic will involve the aspects as follows: In terms of modeling, I will use polygon to create high quality mode; in the aspect of rendering, I will try render passes, AO, Beauty etc. In addition, I will explore how to integrate with animation principles and camera language for smooth transitions.

In my thesis show, I will display my motion graphics through projection on a screen in the lecture room.

## **Game Background**

The game will be designed to occur in 2020. A gang of youths participates in a racing contest using their self-assembled automobile. In this sense, this is a racing game with a tint of futurism.

## **Target audiences**

The target audience will be male and female kids, teenagers, adults and gearheads. They will have the experience in using a computer, or have game platforms, such as PS, X-box, etc.

## **Personas**

### **1. Sam Nicolas**

Sam is 18 years old who is a freshman in college. He usually uses Play Station to play racing games in his spare time. But he is always at sea in the choice of the huge number of racing games, because he can only see the visuals of the games from the motion graphic teaser trailers, rather than the games' features. In this sense, he can choose the racing game easily after he sees my motion graphic.

---

Thesis Title: Create Your Own Car: a motion graphic demo of a new game

By: Peng Peng

Date: February 01, 2012

---

## 2. Danius Burley

Danius, 40 years old, engineer, gearhead, loves racing games during his spare time, especially assembling his own car in the racing game. However, he does not know which game has this interactive feature. In this way, he can choose the racing game through my motion graphic teaser trailer.

## Dissemination

My motion graphic piece will use different formats displayed on different media:

It will be displayed as NTSC in different television game channels, such as GSN, G4, WSB, etc.

It will be displayed as MOV in different game websites, such as AERIA, CARTITANS, etc.

It will be projected on a screen in large competitions, such as SIGGRAPH, WCG, etc.

## Inspiration of literature

The inspiration for my thesis topic derives from the end title sequence of "Iron Man" by John Nelson.

## Source Books:

1. Title: Introduction to Modern Vehicle Design

Author: Julian Happian-Smith

Date of Publication: JUL-2000

An introduction to Modern Vehicle Design' provides a thorough introduction to many aspects of car design in one volume. Based on fundamental principles, the author builds up analysis procedures for all main aspects of vehicle and component design.

Vehicle design is one of the important elements in my motion graphics piece. This book helps me on the evaluation and the selection of the font for my artwork.

I could learn vehicle design principles through this book.

2. Title: The Art of the Automobile: The 100 Greatest Cars

Author: Dennis Adler

Publisher: William Morrow; 1 edition (May 3, 2000)

Award-winning automotive historian, author, and photographer Dennis Adler takes you on a car,

---

Thesis Title: Create Your Own Car: a motion graphic demo of a new game

By: Peng Peng

Date: February 01, 2012

---

whirlwind tour through more than a century of automotive history, from the first production motor car, the 1886 Benz Patent Motorwagen, to famed makes including Hispano-Suiza, Duesenberg, Packard, and Hudson.

More than 200 stunning color photographs define and detail the remarkable styling and revolutionary mechanical engineering for 100 greatest cars ever built. Adler, in accordance with the world's leading automotive designers, collectors, and authorities, picks the top ten cars of all time—breathtaking cars that have become the motoring icons of the twentieth century.

The Art of the Automobile reveals not only the makes and models that have left an indelible mark on the motoring world, but why and how these specific cars have become so important to the history of the automobile itself. For anyone whose pulse quickens at the sound of a Ferrari V-12, or whose heart races at the sight of a glorious 1930s Duesenberg, here, truly, is the essential car book of the century.

For this book, I could promote my modeling and sharing.

### 3. Motion by Design

Author: Spencer Drate, David Robbins, Judith Salavetz

Introduction: Kyle Cooper

Publisher: Laurence King Publishers; Har/DVD edition (December 14, 2006)

The advent of new software and the blurring of disciplinary boundaries have given rise to an entirely new creative category—motion graphics. Motion by Design is the first combined book and interactive DVD package to present the works of some of the world's leading motion graphic studios. The book showcases new work by over 30 international studios, grouped according to genre: Opening Credits, Commercial/Installation and Web, each introduced by a leading motion graphic designer: Garson Yu, Why Not Associates and Hillman Curtis. A main introduction provides a history of motion graphics and a glossary explains the key terms. The accompanying DVD contains not only full samples and reels of almost all of the featured work, but also an interactive historical timeline tracing the development of motion graphic styles. Most importantly, these impressive works will be represented in their element—in motion.

### 4. Title: Motion Graphic Design: Applied history and aesthetics

Author: Jon Krasner Date of Publication: 03/14/2008

Edition or revision: 2nd edition

Publisher: Focal Press

Intended Audience: Designers, Professors, and Students

---

Thesis Title: Create Your Own Car: a motion graphic demo of a new game

By: Peng Peng

Date: February 01, 2012

---

This book is about, how to improve the aesthetic and communication qualities of motion graphics. Reach beyond technical craft skills with this multimedia examination of the essential elements of art, which includes:

Foundation: Realize the artistic expression of pioneering artists from film, television, interactive media, and impressive environments as they combine the principles of painting, traditional graphic design, and the dynamic visual language of cinema.

Technique: Develop an understanding of motion literacy, kinetic images and type, and the pictorial and sequential aspects of composition and choreography. Principles are presented with contextual examples and suggested assignments to challenge you artistically.

This book helps me by giving the fundamental ideas on what makes motion graphics engaging.

5. Title: Motion Blur: 1 – The OneDotZero Book

Author: OneDotZero

Publisher: Laurence King Publishers; Pap/DVD edition (July 13, 2006)

Moving-image production is no longer restricted to filmmakers with privileged access to equipment, skills and budgets. Desktop digital filmmaking has given graphic designers, illustrators and new media artists the means to create moving images, giving rise to a new wave of cutting-edge work. Onedotzero examines the new generation of moving-image makers who are currently pushing the boundaries of motion graphics, broadcast design, digital film effects and animation. With a strong focus on graphic design and digitally manipulated film, the book profiles and investigates the work of 28 cross-media artists from around the world. These filmmakers are revolutionizing the digital moving image, working in a myriad of forms, including short films, music videos, animation, new media and illustration. The book uses interviews, photography, storyboards, and sketches as well as screen grabs to explore the work and reveal the creative processes behind it.

In my project I am planning to do motion graphic for my teaser trailer, this book would help me in motion graphic style.

6. Title: Motion Blur: 2 - Multidimensional Moving Imagemakers

Author: Onedotzero (Author)

Publisher: Laurence King Publishers; Pap/DVD edition (November 8, 2007)

With its pioneering vision, Onedotzero champions new forms of moving image, and this book celebrates the next generation of creators who are accelerating the medium into the 21st cen-



---

Thesis Title: Create Your Own Car: a motion graphic demo of a new game

By: Peng Peng

Date: February 01, 2012

---

ture, following the success of the first Motion Blur. It features 27 international filmmakers who are exploring the evolving possibilities of motion graphics, broadcast design, digital film effects, and animation. Their work is illustrated by screen grabs, storyboards, and sketches, and the groundbreaking nature of their work is highlighted in exclusive interviews and short texts accompanying every production.

This book would help me that how to explore my motion graphic piece.

7. Title: Pause: 59 minutes of motion graphics

Author: Julie Hirschfeld, Stefanie Barth, Peter Hall, Andrea Codrington

Publisher: Universe Publishing; Presumed First edition (May 19, 2000)

With its dynamic synthesis of such diverse media as film, animation, graphics and music, video design provides an expansive view into the many states of contemporary creativity. Pause tracks and contextualizes the visual and technological trends that mark the work of the most innovative video designers. As well as broadcast work, Pause examines demo reels, music videos, film titles, animation and experimental 3-D graphics.

Contributing video artists include Tomato, The Attik, Intro, MTV, Fuel, Tycoon Graphics, Richard Kennworthy, Mike Mills and many others from the US, UK, France, Germany, Holland, Japan, Scandinavia and other countries. Work is arranged according to type, rather than author or history, and each chapter is devoted to a theme, with a short introduction. The book also includes an introductory essay and timeline on the development of motion graphics since the widespread acceptance of television.

I could get inspirations from this book for my motion graphic piece.

8. Title: Learning Autodesk Maya 2009: official Autodesk training guide

The modeling & animation handbook

Publisher: Autodesk Maya Press, 2009

This book helps me to increase my modeling and animation ability.

## **Online Documents:**

1. Title: Gnomon UV Mapping for Games

The author introduces the tools, which can help me to create UV maps efficiently.

Including tools:

- UTE (UV editor)

---

Thesis Title: Create Your Own Car: a motion graphic demo of a new game

By: Peng Peng

Date: February 01, 2012

---

- create UV Shells
- Mirroring UV
- Transferring UV
- Shell array
- Mapping

2. Title: Gnomon Hard Surface Texture Painting Vehicle Texture Painting

UV Layout

Texture Planning

Using Reference

Metallic and Painted Surfaces

Painting Hardware and Signage

Painting Wear and Tear

Reflection and Specular Maps

This course covers hard surface, which is necessary for me to learn fundamental elements of vehicle.

3. Title: Digital Tutors Introduction to mental ray in Maya 2009

The course will study practical job in technological process. It will carry out the accurate simulation on an actual illumination. Also it will explain various type surfaces exaggerates, which is high-performance to new function of mental ray : exaggerating an implement carrying out all-round summary.

4. Title: Digital Tutors Intermediate Poly/Sub-D Training Kit

The course will cover from curve to final render, the complete training kit for polygon and sub-d artists.

This book helps me to build the high quality vehicle model by using 3D techniques in Maya.

5. Title: Digital Tutors creating cartoon vehicles in Maya

I can learn the production of workflow for stylized cartoon vehicles, look development, UV layout, texturing, lighting, and art direction and a multitude of time-saving techniques for modeling. It also contains over 6 hours of project-based training for artists learning the artistic processes of creating vehicles as seen in animated feature films.

6. Title: Digital Tutors Maya Modeling Techniques: Interiors

Popular highlights include: Polygon to Subdivision Workflow; Methods for Creating Clean Geometry; Adding Edge Resolution; Insert Edge Loop Tool; Offset Edge Loop Tool; Bevel Tool; Bridge Tool; Extrude Tools; Optimizing Geometry for Lighting; Strategically Adding Details; Re-purposing

---

Thesis Title: Create Your Own Car: a motion graphic demo of a new game

By: Peng Peng

Date: February 01, 2012

---

Geometry; Making Resolution Decisions; Breaking Up Lines for Visual Aesthetics; Isolating Resolution; Hard-surface Modeling Techniques; Modeling with Deformers; Creative Practices with Paint Effects; Complex Scene Management.

This course will support me on my interior models of the vehicle.

7. Title: Digital Tutors RealFlow and Maya Integration

Create and render advanced photorealistic dynamic and liquid simulations using RealFlow, Maya, and mental ray. Popular highlights include: Importing Geometry to RealFlow; Daemons; Advanced Mesh Generation; Keyframing in RealFlow; Particle and Mesh Loaders; Exporting Particles and Meshes; Scene Setup in Maya; mental ray Materials; Photons; Caustics; Particle Expressions.

8. Title: Digital Tutor Rendering RealFlow Meshes in Maya

The course will give me an introduction to how to use a variety of lighting and shading tools in mental ray to simulate the appearance of realistic liquid materials.

9. Title: Digital Tutors Render Passes In Maya 2009

Learn a production workflow to the completely updated Render Pass feature set in Maya 2009. Gain precise control over render outputs and learn timesaving techniques to optimizing the interoperability with Maya and compositing applications such as Toxik.

---

Thesis Title: Create Your Own Car: a motion graphic demo of a new game

By: Peng Peng

Date: February 01, 2012

---

## Bibliography:

### Source books:

1. Title: Introduction to Modern Vehicle Design  
Author: Julian Happian-Smith  
Date of Publication: JUL-2000
2. Title: The Art of the Automobile: The 100 Greatest Cars  
Author: Dennis Adler  
Publisher: William Morrow; 1 edition (May 3, 2000)
3. Motion by Design  
Author: Spencer Drate, David Robbins, Judith Salavetz  
Introduction: Kyle Cooper  
Publisher: Laurence King Publishers; Har/DVD edition (December 14, 2006)
4. Title: Motion Graphic Design: Applied history and aesthetics  
Author: Jon Krasner  
Date of Publication: 03/14/2008  
Edition or revision: 2nd edition  
Publisher: Focal Press
5. Title: Motion Blur: 1 – The OneDotZero Book  
Author: Onedotzero  
Publisher: Laurence King Publishers; Pap/DVD edition (July 13, 2006)
6. Title: Motion Blur: 2 - Multidimensional Moving Iagemakers  
Author: Onedotzero (Author)  
Publisher: Laurence King Publishers; Pap/DVD edition (November 8, 2007)
7. Title: Pause: 59 minutes of motion graphics  
Author: Julie Hirschfeld, Stefanie Barth, Peter Hall, Andrea Codrington  
Publisher: Universe Publishing; Presumed First edition (May 19, 2000)
8. Title: Learning Autodesk Maya 2009: official Autodesk training guide  
The @modeling & animation handbook  
Publisher: Autodesk Maya Press, 2009

### Online Documents:

1. Title: Gnomon UV Mapping for Games
2. Title: Gnomon Hard Surface Texture Painting Vehicle Texture Painting
3. Title: Digital Tutors Introduction to mental ray in Maya 2009
4. Title: Digital Tutors Intermediate Poly/Sub-D Training Kit

---

Thesis Title: Create Your Own Car: a motion graphic demo of a new game

By: Peng Peng

Date: February 01, 2012

---

5. Title: Digital Tutors Creating Cartoon Vehicles in Maya
6. Title: Digital Tutors Maya Modeling Techniques: Interiors
7. Title: Digital Tutors RealFlow and Maya Integration
8. Title: Digital Tutor Rendering RealFlow Meshes in Maya
9. Title: Digital Tutors Render Passes In Maya 2009

---

Thesis Title: Create Your Own Car: a motion graphic demo of a new game

By: Peng Peng

Date: February 01, 2012

---

## Vehicle Sketch



---

Thesis Title: Create Your Own Car: a motion graphic demo of a new game

By: Peng Peng

Date: February 01, 2012

---

## Storyboard

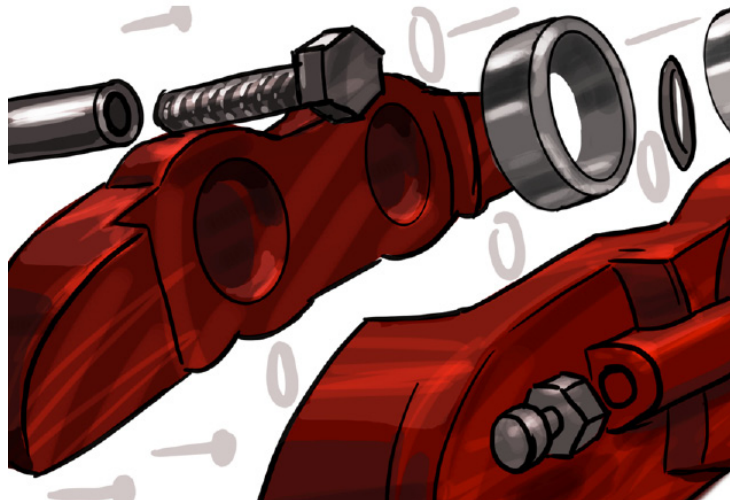

1. The first shot starts from the car brake. Screws, gears, and other components will be integrated into a car brake. (Extreme Close-up, 4S')

**TIRE BRAKE**

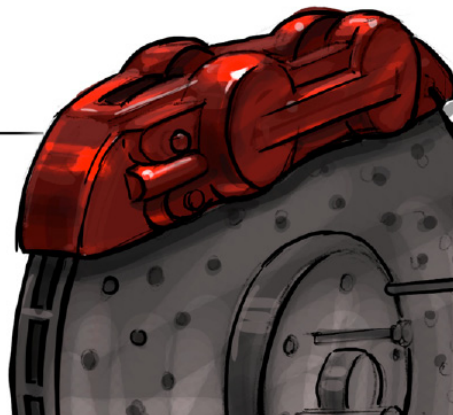

2. The shot zooms out from Extreme Close-up to Close-up. In the right side of the visual, car brake finish assembling and the descriptive characters TIRE BRAKE will pop up on the left side. (Close-up, 3S')

---

Thesis Title: Create Your Own Car: a motion graphic demo of a new game

By: Peng Peng

Date: February 01, 2012

---

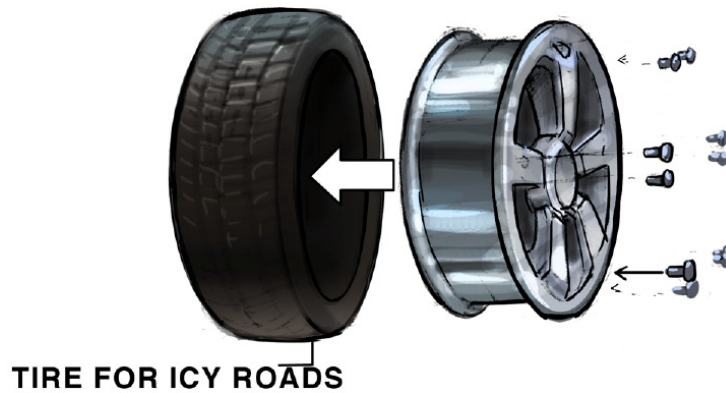

3. The shot will zoom out from Extreme Close-up to Close-up quickly. In the Close-up shot, the parts such as brake, wheel, and screws will show up. Then, these parts will be integrated into a complete tire. Then the descriptive characters TIRE FOR ICY ROADS pop up in the left bottom of the visual. (Extreme Close-up to Close up, 4S')

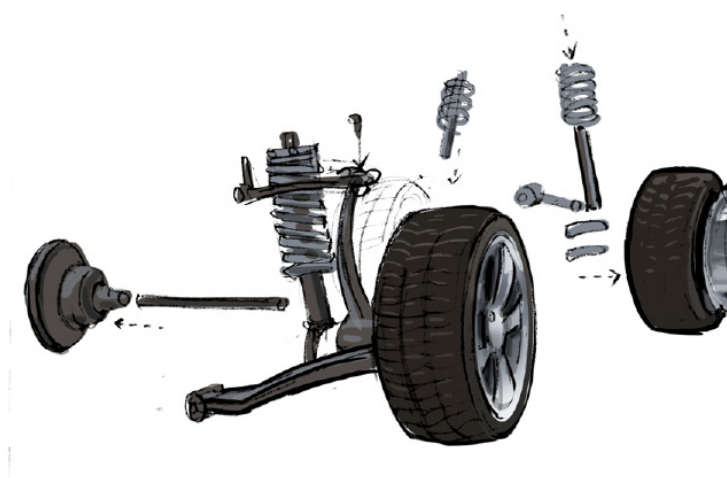

4. The shot slowly zooms out and pans clockwise. Then the car's other three tires in the process of assembling will show up in this visual. At the same time, the chassis related with tires will be integrated by springs, screws and other components. (Full Shot, 3S')



---

Thesis Title: Create Your Own Car: a motion graphic demo of a new game

By: Peng Peng

Date: February 01, 2012

---

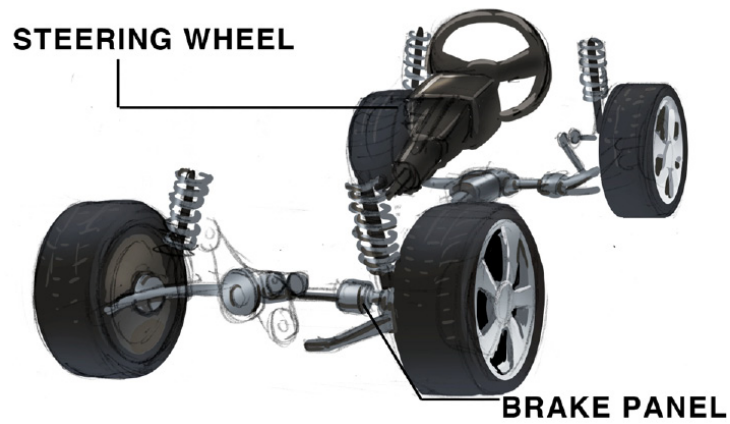

5. The shot will pan clockwise at an even speed and zoom in. The car chassis will take place in the center of the visual. Then, other interior parts such as steering wheel, brake panel begin to be assembled in this visual. The descriptive characters STEERING WHEEL, BRAKE PANEL will be displayed simultaneously. (Full Shot, 4S')



6. The shot continues panning clockwise and zooms in. In this visual, audiences will see the inner construction of the car. (Full Shot, 4S')

---

Thesis Title: Create Your Own Car: a motion graphic demo of a new game

By: Peng Peng

Date: February 01, 2012

---

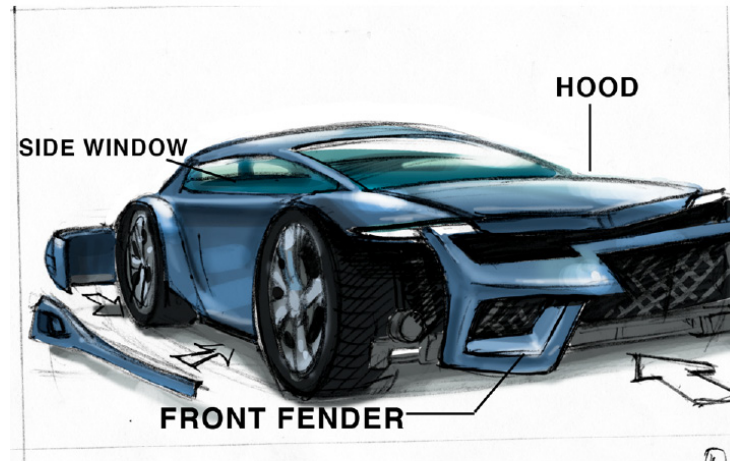

7. The shot goes on panning clockwise at an even speed, and turns to zoom out. Car exterior construction will show up, such as lights, hoods, fender, etc. Simultaneously, the descriptive characters pop up. (Full Shot to Long Shot, 4S')

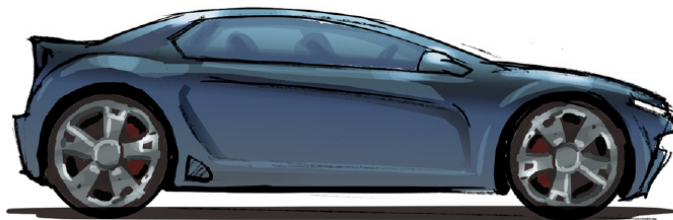

8. The shot stops moving. In the lower position of the visual, the entire assembled car begins to move forward. (Long Shot, 4S')

---

Thesis Title: Create Your Own Car: a motion graphic demo of a new game

By: Peng Peng

Date: February 01, 2012

---

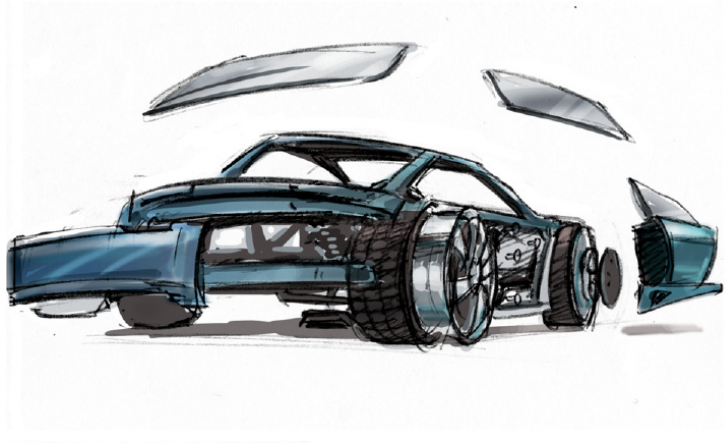

9. The shot pans clockwise and zooms in at the same time. In the process of zooming in, the car will separate into different parts. (Long Shot to Close-up, 5S')

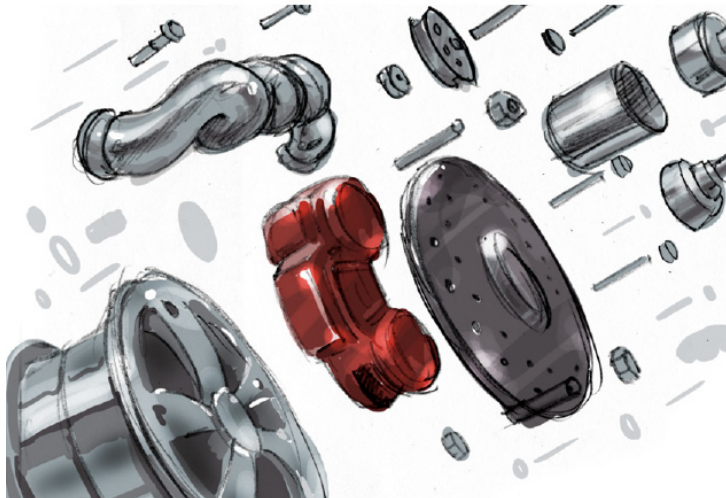

10. The shot zooms in quickly. The visual will display the right back car-tire separated into different parts, such as car brakes, screws, and discs, etc. Then, these parts will separate into different components, such as screws, springs, etc. And all of these components are going to integrate into another car tire. (Close-up to Extreme Close-up, Montage, 5S')

---

Thesis Title: Create Your Own Car: a motion graphic demo of a new game

By: Peng Peng

Date: February 01, 2012

---

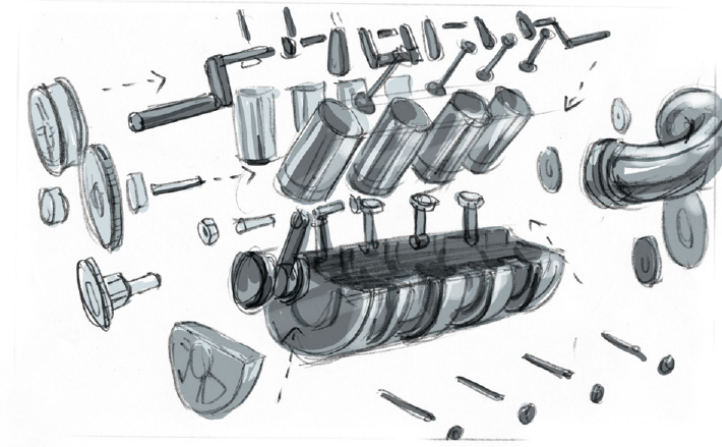

11. The shot cuts to another shot. The assembly of the engine will show up in this visual. All kinds of components will be integrated into an entire engine, such as gears, screws and springs, etc. (Extreme Close-up, 3S')



12. The shot cuts to another shot. The assembly of the tire is almost completed in this left side visual. Then the descriptive characters pop up. (Tire for dry roads) (Extreme Close-up, Montage, 4S')

---

Thesis Title: Create Your Own Car: a motion graphic demo of a new game

By: Peng Peng

Date: February 01, 2012

---

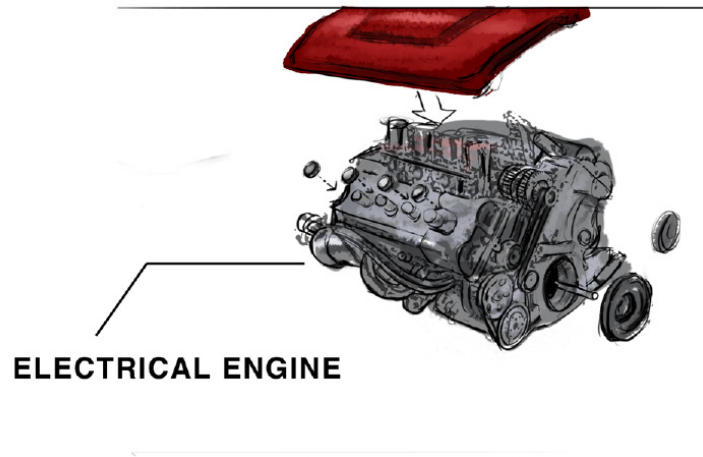

13. The shot cuts to another shot. The assembly of the engine is almost completed in the right side visual. Then, the descriptive characters ELECTRICAL ENGINE pop up. (Extreme Close-up, 4S')

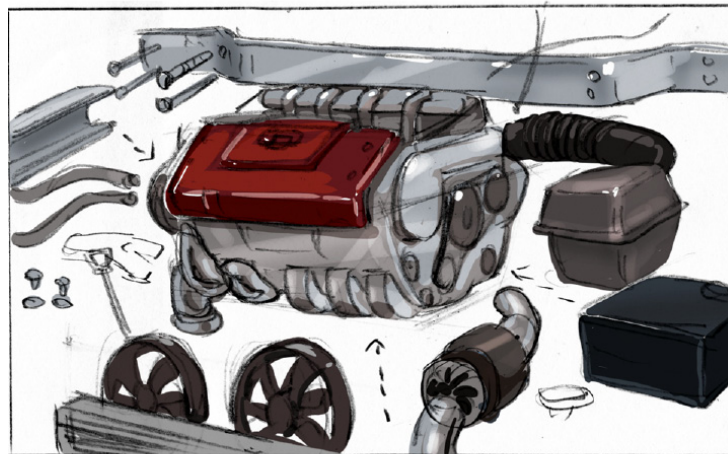

14. The shot zooms out. The assembly of the front of car will show up in this visual. (Full Shot, 4S')



---

Thesis Title: Create Your Own Car: a motion graphic demo of a new game

By: Peng Peng

Date: February 01, 2012

---

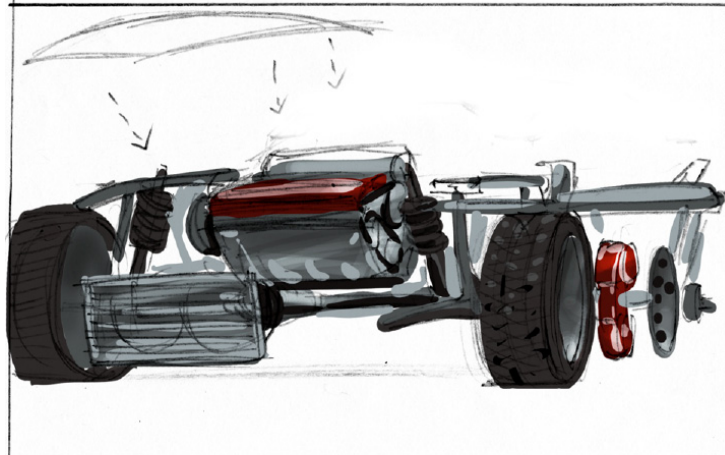

15. The shot zooms out and pans clockwise slightly. Car exterior construction will start to be assembled by using different parts, such as lights, hoods, fenders, etc. (Long Shot, 4S')

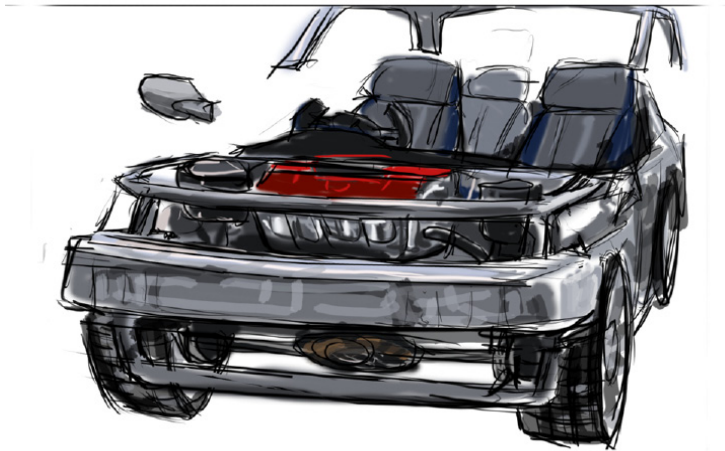

16. The shot zooms out and pans clockwise slightly. The car exterior construction is almost completed in this visual. (Long Shot, 4S')

---

Thesis Title: Create Your Own Car: a motion graphic demo of a new game

By: Peng Peng

Date: February 01, 2012

---



**CREATE YOUR OWN CAR IN YOUR OWN GAME**

17. The shot zooms out slightly. At this time, the car will show up in the upper position of the visual, while "BUILD YOUR OWN CAR IN YOUR GAME" will show up in the bottom of the visual. (Long Shot, 2S')

---

Thesis Title: Create Your Own Car: a motion graphic demo of a new game

By: Peng Peng

Date: February 01, 2012

---

## **Thesis Timeline**

Peng Peng

<b>October</b>	Thesis Proposal Draft	Research of Literature	Design Flowchart	Storyboards	
<b>November</b>	1st Committee Meeting	Feedback	Final Proposal	Thesis Proposal Defense	Thesis Website Established
<b>December</b>	Modeling	Committee Meeting	Feedback		
<b>January</b>	Modeling	Lighting	Committee Meeting	Feedback	
<b>February</b>	Layout UV	Texture Shading	Committee Meeting	Feedback	
<b>March</b>	Animation	Music Editing	Committee Meeting	Feedback	
<b>April</b>	Rendering	Committee Meeting	Feedback	Preparation for Thesis Defense	
<b>May</b>	Rendering	Thesis Defense	Thesis Show		