

Rochester Institute of Technology

RIT Digital Institutional Repository

Theses

2009

Inside all-optical networks

Sana Tariq

Follow this and additional works at: <https://repository.rit.edu/theses>

Recommended Citation

Tariq, Sana, "Inside all-optical networks" (2009). Thesis. Rochester Institute of Technology. Accessed from

This Thesis is brought to you for free and open access by the RIT Libraries. For more information, please contact repository@rit.edu.

Rochester Institute of Technology (RIT)

College of Applied Science & Technology (CAST)

**Electrical Computer and Telecommunications Engineering Technology
(ECTET)**

Inside All-Optical Networks

By Sana Tariq

**A Research Thesis Submitted in Partial Fulfillment of the Requirements
for the degree of**

**Masters of Science in Telecommunications Engineering Technology
(MSTET)**

Rochester, New York, United States

Date Approved: 23rd May 2009

Course Advisor

Prof. Warren L.G. Koontz

Professor and Program Chair
Telecommunications Engineering Technology
College of Applied Science & Technology

Committee Members

Prof. Ronald Fulle

Prof. Mark Indelicato

Telecommunications Engineering Technology
College of Applied Science & Technology

Scope of Document

This document is submitted as a graduate thesis for the MS in Telecommunications Engineering Technology (MSTET) at Rochester Institute of Technology (RIT). The intended audience of this document is the faculty and students of the department of Electrical, Computer and Telecommunications Engineering Technology (ECTET) at the College of Applied Sciences and Technology (CAST).

Preface

In fall 2007, I joined Rochester Institute of Technology (RIT), for the MS Program in Telecommunications Engineering Technology under a Fulbright scholarship. While working with Prof. Warren Koontz in fiber optics courses and Prof Ronald Fulle, I was exposed to cutting-edge technologies of telecommunications. I became extremely inspired by optical communication technologies and its revolutions in telecommunications industry.

Optics will change the face of the telecom market over the next few decades. During a case study in the course of next generation networks, I realized through my research that by the year 2020 more than 80% of copper cables in the world would be replaced by high capacity fiber optics.

My inspiration to optics and my passion to learn more about it led me to apply for a Fulbright scholarship for doctorate-level research. I received this prestigious award once again for conducting Ph.D. work in optical communication. I was accepted at two of the best Optics Schools in the US, CREOL at the University of Central Florida and College of Optics at University of Arizona. I have also been offered university graduate scholarships and fellowships in admission offers from these prestigious schools. I will start my Ph.D. in Optics this fall at UCF.

I wanted to choose a topic for my thesis that could employ my knowledge of networking and telecommunications gained during my academic and professional career over the past several

years. I also wanted to explore optical communication in further depth as that would set the stage for my future roadmap. I chose to work on all-optical networks, which is the next biggest breakthrough in telecom infrastructure and IP and which has already changed the destiny of man in today's telecom arena.

Acknowledgements

I want to express my heartfelt gratitude to all those whose support and honest contributions helped me complete this work.

First of all, I want to thank God Almighty for showering His unlimited blessings on me throughout my life. I attribute all my success to God Almighty, Whose love and help in my endeavors have always bore fruit.

My sincere thanks go to RIT ECTET department for providing all the support and resources required to complete this work.

It gives me a great pleasure to express my earnest gratitude to my thesis advisor, Prof. Warren L.G Koontz, Program Chair – TET and my course advisor. His always understanding and always supporting attitude helped me achieve my ambitious academic objectives with a relaxed mind. He helped me exploit my full potential for my work without being worn out. He allowed me to follow my interests and guided and supported me in every way possible. He has always been a constant source of energy to his students.

I want to pay special thanks to Prof. Ronald Fulle whose inspiration, vigor and confidence motivated me to do something special in life. It is through his confidence and trust in my abilities that I am able to bring out my best. I thank him once again for helping Prof. Koontz in giving me online access to Opnet Transport Planner, which brought the final touch to my long and tiring research work.

I want to thank all the faculty members of ECTET and NSSA with whom I took courses on telecommunications and Networking that formed the foundation for my thesis. Prof. Mark Indelicato, Prof. Charles Border and Prof. Shenoy helped me achieve crystal clear concepts on tough subjects that helped me with my thesis and will continue to stay with me in my future endeavors.

I also want to express my sincere gratitude to my course advisor, Sydney Seaver whose help and support sailed me through in every difficult situation; from course work to thesis completion and beyond.

It would not be an exaggeration if I attribute a greater part of my success and fulfillment in life to my husband Saad Arif. My thesis could not have been completed without the support and encouragement he offered me throughout. I owe special thanks to my loving and supporting parents and family, who brought me where I am today; they always took pride in my accomplishments. I want to thank God for blessing me with an angel baby girl Irsa, who gave me a new bearing in life and helped me appreciate its beauty and exquisiteness in a new sense.

May God keep them all in His mercy and shower His love upon them always!

Problem Statement

This thesis will to explore various aspects of all-optical networks and prove that All Optical Networks (AONs) perform better than electro-optical networks. Performance analysis of electro-optical and all-optical networks will include node utilization, link utilization and percentage of traffic routed under various conditions of traffic load on the network.

Abstract

Imagine a world where lightning speed Internet is as common as telephones today. Imagine when light, the fastest moving thing in the universe, is the signal-carrying transport medium. Imagine when bandwidth no more remains a constraint for any application. Imagine when imagination is the only limit! This all can be made possible with only one technology and that is optical communication. Optical networks have thus far provided a realization to a greater extent to the unlimited bandwidth dreams of this era, but as the demands are increasing, the electro-optic conversions seem to become bottlenecks in blended optical networks. The only answer to this is a complete migration to ‘All-Optical Networks’ (AONs) which promise an end-to-end optical transmission.

This thesis will investigate various aspects of all-optical networks and prove that AONs perform better than currently existing electro-optical networks. In today’s’ electro-optical networks, routing and switching is performed in electronic domain. Performance analysis of

electro-optical and all-optical networks would include node utilization, link utilization and percentage of traffic routed. It will be shown through Opnet Transport Planner simulations that AONs work better under various traffic conditions.

The coming decade will see a great boom in demands on telecommunications networks. The development in bandwidth-hungry applications like real-time video transmission, telemedicine, distance learning and video on demand require both an unlimited amount of bandwidth and dependable QoS. It is well understood that electrically switched networks and copper cables will not be able to meet the future network demands effectively. The world has already agreed to move towards optical communication techniques through the introduction of fiber in access parts of the networks replacing copper. Now the race is to bring optics in higher layers of OSI reference model. Optical communication is on the horizon, and new discoveries are still underway to add to the value of available bandwidth through this technology.

My research thesis will primarily focus on the design, architecture and network properties of AONs and challenges being faced by AONs in commercial deployment. Optical components required in AONs will be explored. A comparison between AONs and electro-optical networks will also be shown through optical transport planner simulations.

Key words: All-Optical Networks, IP, Protocols, Optical Transport Planner, Optical Components

Introduction

This document is presented as a detailed thesis on all-optical networks. It is broken down into chapters, each chapter highlighting different aspects of these networks. Below we provide a brief overview of how this document is organized.

Chapter 1 begins with the introduction of optics. The past, present and future role of optics in telecommunications industry is discussed. Optics is gaining importance in various research areas due to a number of applications in military, medicine, industry, space explorations and telecommunications. The use of optics in telecommunications is the main focus of this thesis.

Chapter 2 discusses the reasons for migration towards all-optical networks. Since the Internet is becoming the center of future services, it would require a much larger bandwidth that is only possible by completely avoiding electronic bottlenecks throughout the network. Various advanced concepts are also presented. The promise of a bandwidth satisfying future demands is enough to bring the technology from research test bed to the market.

In chapter 3, we have presented the evolution process of all-optical networks. Telecommunication networks went through various transitions and constantly evolved to meet bandwidth demands as applications and services developed. We have presented three generations of network evolution. Chapter 4 discusses the invention of those devices that paved the way to all-optical networks. These include devices involved in optical signal generation and reception (such as light sources, transmitters and receivers), devices that are

responsible for end-to-end transmission of optical signals (like optical fibers, amplifiers and couplers) and the devices that are responsible for routing these signals to the correct path (optical switches and routers).

Chapter 5 discusses various multiplexing techniques that are employed in all-optical networks. In this section, we discussed three popular types namely optical time division multiplexing (OTDM), code division multiple access (CDMA) and wavelength division multiplexing (WDM).

Chapter 6 is about various architectural forms of WDM networks, their advantages and disadvantages and their implementation limitations. In chapter 7, we have discussed the most commonly categorized types of all-optical networks. Chapter 8 begins with a discussion on importance of IP in today's communications world and it then presents the idea of having the strengths of IP world combined with those of all-optical networks. In chapter 9, overall network architecture of WDM optical networks is explained. The relation of optical network layers with OSI reference model is highlighted.

Chapter 10 discusses project Flamingo, which is one of the current projects on all-optical networks. We have provided a brief design and architecture of this project. In chapter 11, we have discussed the routing in all-optical networks. We have presented a few important protocols in reference to optical domain and their possible extensions. Chapter 12 is about the challenges being faced in the process of implementation of all-optical networks. We have presented technical issues as well as financial and non-technical ones.

Chapter 13 involves the implementation of WDM networks on OPNET Transport Planner.

We have provided a comparison between all-optical networks and networks that have electro-optical conversions and concluded that all-optical networks are the favorite choice of the future.

List of Acronyms

AON	All-Optical Networks
AP	Access Points
ATM	Asynchronous Transfer Mode
BER	Bit Error Rate
CDMA	Code Division Multiple Access
DWDM	Dense Wavelength Division Multiplexing
EDFA	Erbium Doped Fiber Amplifier
EMI	Electro Magnetic Interference
FTTH	Fiber to the Home
FTTC	Fiber to the Curb
FTTP	Fiber to the Premises
IETF	Internet Engineering Task Force
IP	Internet Protocol
IS-IS	Intermediate Systems Intermediate Systems
ITU	International Telecommunication Union
LED	Light Emitting Diode
LASER	Light Amplification by Stimulated Emission of Radiation
OTDM	Optical Time Division Multiplexing

OOO	Optical-Optical-Optical
OSI	Open Standard Interface
OSPF	Open Shortest Path First
OXC	Optical Cross-Connect
PON	Passive Optical Network
QoS	Quality of Service
RIP	Routing Information Protocol
RWA	Routing Wavelength Assignment
SDU	Service Data Units
TCP	Transmission Control Protocol
TON	Transparent Optical Network
UDP	Universal Datagram Protocol
WDM	Wavelength Division Multiplexing
WIXC	Wavelength Interchange Cross-Connect
WRN	Wavelength Routed Network
WSXC	Wavelength Selective Cross-Connect

Table of Contents

LIST OF FIGURES	14
LIST OF EQUATIONS	14
OPTICS: A BRIEF HISTORY	14
INTRODUCTION	14
PAST: OPTICS IN TELECOMMUNICATIONS	14
PRESENT: OPTICS IN TELECOMMUNICATIONS	14
FUTURE: OPTICS IN TELECOMMUNICATIONS	14
CONCLUSION	14
DRIVERS FOR ALL-OPTICAL NETWORKS	14
INTRODUCTION	14
USE OF INTERNET	14
GRAPHICS AND 3D ENVIRONMENT	14
ONLINE MEDICAL CARE (TELE-MEDICINE)	14
BUSINESS VIDEO CONFERENCING	14
REMOTE ASSISTANCE	14
TRIPLE PLAY AND FUTURE HOME SERVICES	14
CONCLUSION	14
AON EVOLUTION	14
INTRODUCTION	14
TELECOMMUNICATIONS NETWORK EVOLUTION	14
CONCLUSION	14
OPTICAL COMPONENTS LEADING TO AONS	14
INTRODUCTION	14
LIGHT SOURCES	14
OPTICAL FIBER	14
<i>Single-Mode Vs Multimode Fiber</i>	14
ALL-OPTICAL WIDE-BAND AMPLIFIERS	14
<i>Semi-conductor Laser Amplifier</i>	14
<i>Doped Fiber Amplifier</i>	14
OPTICAL COUPLERS	14
TUNABLE LASERS (TRANSMITTERS)	14
TUNABLE FILTERS (RECEIVERS)	14
OPTICAL SWITCHING	14
<i>Relational Switches</i>	14
<i>Logic Switches</i>	14
PHOTONIC PACKET SWITCHES	14

WAVELENGTH CONVERSION _____	15
CONCLUSION _____	15
MULTIPLEXING TECHNIQUES IN AONS _____	15
INTRODUCTION _____	15
OTDM – OPTICAL TIME DIVISION MULTIPLEXING _____	15
CDM – CODE DIVISION MULTIPLEXING _____	15
WDM – WAVELENGTH DIVISION MULTIPLEXING _____	15
CONCLUSION _____	15
ARCHITECTURAL FORMS OF WDM NETWORKS _____	15
INTRODUCTION _____	15
WDM LINKS _____	15
PASSIVE OPTICAL NETWORKS (PON) _____	15
BROADCAST AND SELECT NETWORK _____	15
<i>Physical topologies in Broadcast and select network</i> _____	15
<i>WDM broadcast and select network advantages/disadvantages</i> _____	15
WAVELENGTH ROUTING WDM NETWORKS _____	15
<i>WRN-Fiber Cross Connect</i> _____	15
<i>WRN-Add drop Multiplexers</i> _____	15
<i>WRN-Static wavelength router</i> _____	15
<i>WRN-Reconfigurable wavelength router</i> _____	15
CONCLUSION _____	15
TYPES OF ALL-OPTICAL NETWORKS _____	15
INTRODUCTION _____	15
PASSIVE OPTICAL NETWORKS (PONs) _____	15
TRANSPARENT OPTICAL NETWORKS (TONs) _____	15
ULTRA-HIGH SPEED OPTICAL NETWORKS: _____	15
CONCLUSION _____	15
IP OVER ALL OPTICAL NETWORK _____	15
INTRODUCTION _____	15
IP IN TODAY’S COMMUNICATIONS _____	15
IP AND OPTICAL COMMUNICATIONS _____	15
CONCLUSION _____	15
OVERALL NETWORK ARCHITECTURE OF AONS _____	15
INTRODUCTION _____	15
OPTICAL LAYER IN OSI REFERENCE MODEL _____	15
SUB-LAYERS OF OPTICAL LAYER _____	15
GENERIC ARCHITECTURE OF OPTICAL WDM NETWORK _____	15
CONCLUSION _____	15

ALL-OPTICAL NETWORK: PROJECT FLAMINGO	16
INTRODUCTION	16
FLAMINGO'S SCOPE	16
FLAMINGO'S ALL-OPTICAL NETWORK	16
CONCLUSION	16
ROUTING IN ALL-OPTICAL NETWORKS	16
INTRODUCTION	16
ROUTING IN OPTICAL NETWORKS	16
ROUTING INFORMATION PROTOCOL (RIP)	16
INTERMEDIATE SYSTEMS-INTERMEDIATE SYSTEMS (IS-IS)	16
OPEN SHORTEST PATH FIRST (OSPF)	16
CONCLUSION	16
CHALLENGES FACED IN DEPLOYING AONS	16
INTRODUCTION	16
ROUTING AND WAVELENGTH ASSIGNMENT	16
<i>Static Vs Dynamic Traffic Demand</i>	16
<i>Centralized Vs Distributed Control</i>	16
<i>Wavelength Convertible Networks</i>	16
LACK OF SWITCHING/ROUTING EQUIPMENT	16
HIGH CAPEX FOR AONS	16
LACK OF NETWORK INTELLIGENT TOOLS	16
LACK OF TRAINED PROFESSIONALS	16
CONCLUSION	16
OPTICAL TRANSPORT PLANNER SIMULATIONS	16
INTRODUCTION	16
DESIGNING A NETWORK BASED ON FLAMINGO MODEL	16
PERFORMANCE COMPARISON: OOO Vs OEO NETWORKS	16
IMPACT OF INCREASING NUMBER OF WDM WAVELENGTHS	16
CONCLUSION	16
CONCLUSION	16
REFERENCES	16
APPENDIX A	16
APPENDIX B	16

List of Figures

Figure 1: <i>Three Generations of Networks</i>	9
Figure 2: <i>Propagation of Light through an Optical Fiber.</i>	12
Figure 3: <i>Total Internal Reflection in Optical Fibers.</i>	13
Figure 4: <i>(a) Multimode Fiber (b) Single Mode Fiber.</i>	15
Figure 5: <i>A semiconductor optical amplifier.</i>	18
Figure 6: <i>Erbium doped fiber amplifier.</i>	19
Figure 7: <i>(a) Splitter, (b) combiner and (c) coupler.</i>	19
Figure 8: <i>2 x 2 optical cross-connect (a) bar and (b) cross state.</i>	23
Figure 9: <i>A 4 x 4 non-reconfigurable wavelength router.</i>	24
Figure 10: <i>A P x P reconfigurable routing switch with M wavelengths.</i>	25
Figure 11: <i>The CORD architecture.</i>	27
Figure 12: <i>a) Wavelength selective cross-connect and) wavelength Interchanging cross connect</i>	28
Figure 13: <i>The low attenuation region of optical fiber.</i>	30
Figure 14: <i>Block diagram of a WDM transmission system.</i>	31
Figure 15: <i>Transmitter and receiver structures.</i>	31
Figure 16: <i>WDM Link.</i>	33
Figure 17: <i>A Typical Passive Optical Network (PON)</i>	34
Figure 18: <i>PON, connecting CO and ONUs.</i>	35
Figure 19: <i>WDM network with combiner/splitter</i>	36
Figure 20: <i>Broadcast and Select Organizations: a) Star b) Bus c) Ring.</i>	36
Figure 21: <i>Wavelength routing network.</i>	40
Figure 22: <i>2 x 2 Cross Connects, (a) Bar State and (b) Cross State.</i>	41
Figure 23: <i>Acousto-optic Tunable Filter.</i>	42
Figure 24: <i>A 4 x 4 static wavelength router and its connections matrix.</i>	43
Figure 25: <i>A 3 x 3 reconfigurable wavelength router.</i>	44
Figure 26: <i>A Typical Passive Optical Network (PON)</i>	46
Figure 27: <i>Graph of Internet users per 100 inhabitants between 1997 and 2007 by ITU</i>	50
Figure 28: <i>(a) Typical protocol stack and (b) simplified protocol stack.</i>	52
Figure 29: <i>Evolution of Optical Layer in OSI reference model</i>	55
Figure 30: <i>Optical layer -sub layers</i>	57
Figure 31: <i>Generic optical WDM network architecture</i>	58
Figure 32: <i>Interconnected City rings, AP-access points, B-intelligent bridges.</i>	60
Figure 33: <i>Opnet Transport Planner Flamingo based network model</i>	73
Figure 34: <i>Flamingo based Electro-Optical Network</i>	74
Figure 35: <i>OOO Network Performance with Random Traffic Matrix (1-15).</i>	76
Figure 36: <i>OEO Network Performance with Random Traffic Matrix (1-15)</i>	76
Figure 37: <i>Graph of OOO vs. OEO network (node utilization)</i>	78

Figure 38: <i>Graph of OOO vs. OEO network (Link Utilization)</i>	78
Figure 39: <i>Graph of OOO vs. OEO network (% traffic routed)</i>	79
Figure 40: <i>OOO Network Performance with doubled WDM Wavelengths</i>	80
Figure 41: <i>OEO Network Performance with doubled WDM Wavelengths</i>	80

List of Equations

Equation 1: Critical angle - Snell's Law.	13
Equation 2: Condition for Total Internal Reflection	14
Equation 3: Number of modes in a multimode fiber.	16
Equation 4: Normalized frequency.....	16
Equation 5: Max wavelengths converters for a node in WDM network.....	69

1. Optics: A Brief History

1.1 Introduction

‘Optics is the science of light’ or more formally “the branch of physics that deals with light and vision, chiefly the generation, propagation, and detection of electromagnetic radiation having wavelengths greater than x-rays and shorter than microwaves [1].” Optics is gaining increasing importance in various research areas due to a number of applications in military, medicine, industry, space explorations and telecommunications. The use of optics in telecommunications is the main focus of this thesis.

1.2 Past: Optics in Telecommunications

It would be interesting to know that in 1880s Alexander Graham Bell tried to use optical signal to carry voice through atmosphere. He made a telephone which he named *Photophone*. He attempted to send the optical signal through air. Disappointed by loss of signal in the air due to atmosphere, brilliant Alexander donated the experimental photo-phone to Smithsonian Institution, where it stayed on shelf for years [2].

The invention of optical fiber cable is attributed to Kao and Hockham (1965). The possibility of communication through total internal reflection over optical fiber was first discovered by Maurer et al. in 1970, without knowledge that he paved the way for biggest revolution of

telecom for a future two decades ahead. Invention of lasers also played a crucial role in making the attempts of optical signal transmission a reality.

1.3 Present: Optics in Telecommunications

Today optical communication has taken its place in access parts of telecom networks. With the widespread use of Internet over past decade, the requirement for high bandwidth transmission medium forced the use of optical fiber at physical layers. The introduction of fiber in transmission layer, replacing copper, has increased the available bandwidth many folds. Verizon's FTTH and NTT Docomo in Japan are examples of networks that have deployed this technology. FTTH technology is spreading across Europe and Asian parts of the world as well, serving people with high-speed Internet, video telephony, telemedicine, distance learning and cable services.

For using optical communication at lower layers we need O-E-O conversions. A light signal that leaves one end of transmission in optical domain is converted into electrical before processing and routing through core network. Transmission speeds are very high but processing speeds in core are comparatively slower due to electrical domain. Today the types of telecom services that have dominated the Internet are mostly data rather than voice like in the past. More and more bandwidth-intensive applications are coming and the existing capacity on fiber links seems to be lacking in its ability to support the surge. Moreover, O-E-O networks are only feasible on a smaller scale. As the traffic grows and network size increases, the equipment usage required for these conversions reduces the overall benefits of

optical communication. It is already anticipated that optical communication will ultimately become the survivor of World Wide Web when future applications are placed in it. The dream of optical Internet and many other large-scale telecom networks supporting future bandwidth demands could only be made a reality with next generation All-Optical networks. The possibility of optical communication over www is explored in this thesis with discussion on All-Optical networks in chapter 8.

1.4 Future: Optics in Telecommunications

The requirement of optical communication supporting future applications and larger scalable networks led to the concept of all-optical networks. Optical communication technologies employ optical signals to carry information over optical fiber at the speed of light. Until now optical networks used signal propagation in form of light pulses, but switching and routing was being done in the form of electrical signals. This involved O-E-O conversions. The conversion of optical signals into electrical and then back to optical involved high equipment cost, additional overhead and delays, while offering limited bandwidth. Today's ongoing research in all-optical networks ensures that all user-network and network-network interfaces are based on optical transmission. AONs also include network components, e.g., switches and routers that have the capability of processing optical signals. The main advantage of avoiding electro-optic conversions in the network is to keep a higher optical bandwidth throughout transmission which results in fewer bottlenecks in the network. In fact, the actual benefits of

optical communications could only be enjoyed when optical communication is brought to the upper layers of OSI model involving switching and routing.

A very important aspect in AONs is transparency, which means that the data flows through the network without being interpreted in switches or routers. Transparency brings advantages of security and ease in network upgrades, i.e., network upgrades at terminals do not require changes on networks themselves. Commercial all-optical networks are still not in place and mostly exist in research arena. Only limited AON functions are being deployed in commercial networks. AON is still considered a technology of the future!

There are two broad classes of AONs. The first class is WDM which uses various wavelengths of light as separate channels of traffic on a single fiber to carry different streams of traffic simultaneously. The second class is TDM which uses time-division multiplexing. This thesis will concentrate on WDM optical networks.

WDM networks can be further divided into two main classes; broadcast-and-select networks and wavelength-routed networks. In the first type all incoming signals are routed to all users and user's equipment then separates the required signal for use. In wavelength routing, each wavelength carries a particular user's signals and routing is done on basis of individual wavelengths. A particular wavelength arriving at one port is routed to another port at the same or a different wavelength.

Wavelength routing is an advanced version of WDM AONs. It can promise a higher scalability and dynamic routing for traffic optimization . While in simple broadcast-and-

select networks, there is less processing overhead and they are considered ideal for smaller networks. We will discuss the different approaches of implementing AONs in the next section.

1.5 Conclusion

In this section we discussed optics as a branch of science that deals with the study of light. The history of optics can be traced back to 17th century. The role of optics in telecommunications was initiated with the invention of Bell's photo phone and discovery of lasers. The role of optics in today's telecom infrastructure is already paramount. We also discussed the future of telecom networks when more and more optics will penetrate the networks, giving an incredibly high data rate for future networks.

2. Drivers for All-Optical Networks

2.1 Introduction

In this chapter we will discuss the reasons of migration towards all-optical networks. It was already discussed that Internet is becoming the center of future services and would require a much larger bandwidth that is only possible by completely avoiding electronic bottlenecks throughout the network. "The total bandwidth of radio on the planet is 25GHz, whereas each fiber hair has a capacity of 25,000GHz. Moreover, silica fiber can carry an infrared signal for many miles with extremely low loss" [1]. The promise of a bandwidth satisfying future demands is enough to bring the technology from research test bed to the market.

2.2 Use of Internet

Internet users are increasing exponentially. The expectations of users from their Internet are also increasing due to the availability of bandwidth intensive applications. Heavy graphical user interfaces, online gaming, Java-enabled active pages, live audio and video streaming put pressure on service providers to maintain an acceptable QoS along with meeting all future connections and service demands. The trend helps us visualize a future where not only the access part but entire network functions will perform in optical domain.

2.3 Graphics and 3D environment

Achieving realistic graphics quality requires both high-speed computing device and communication medium. Online gaming with quality graphics involves transmitting higher number of frames per second and high picture quality in each frame. Here we are talking about bandwidth nearly 1 GHz. Similarly, the use of Internet by scientists for observing simulations and sharing experimental results in run-time being millions of miles away (e.g., CERN) would require bandwidth of Giga bits/s with no delay.

2.4 Online medical care (Tele-Medicine)

Manual record keeping in hospital files is old fashioned. Each patient's history and reports are now saved electronically. Imagine a patient on travel who encounters a life-threatening emergency; his doctor would need his medical records instantly. Or a surgeon elsewhere might need to monitor his radiological reports (e.g., CT-Scan, MRI) online to make

immediate decisions. This would certainly require a high-speed network with excellent QoS. Here a bad QoS can mean loss of life. This could only be made possible by realizing an optical Internet for the future. Tele-medicine support to rural areas could also be achieved by improving tele-medicine feasibility.

2.5 Business Video Conferencing

In order to avoid business-related travel, many companies are moving towards the concept of video conferencing. The quality of image, number of frames/second, picture-voice delivery accuracy and avoiding delays are extremely challenging, as existing IP is just a best effort service. Even if there is a broadband connection, electronic bottlenecks might be present throughout the network.

2.6 Remote Assistance

In telecom and other industries vendor's headquarters are usually in one country while the equipment is deployed world over. Giving a level-3 support through remote assistance is a popular concept. Applying commands on a live network node will demand accuracy as well as reliable service quality. A packet loss or extra delay could mean millions of dollars loss in seconds.

2.7 Triple play and future home services

Telecom operators are already working to provide innovative recreational facilities to their users. Each application requires high bandwidth and excellent QoS so the operators are busy

deploying fiber in access parts of their networks also called as '*last mile*'. The trend of today's networks and pressure on service providers predicts that just getting fiber in the last mile would not be sufficient, as the number of users interested in these services is also increasing with every passing day.

2.8 Conclusion

The applications discussed are numerous and more are still emerging on the horizon that might lead towards a dream Internet made by all-optical WDM network, thus relieving the existing networks with strained network capacity and creating a new era of business and technology for human life.

3. AON Evolution

3.1 Introduction

An all-optical network is a powerful concept of future networks. Telecommunication networks went through various transitions and constantly evolve to meet bandwidth demands as applications and services are being developed. We will see three major evolution stages of telecom networks in this section.

3.2 Telecommunications Network Evolution

As they evolved, the networks can be broadly categorized in three generations:

- **1st Generation (Copper Cable)**

- 2nd Generation (Optical in Access, Electronic in Core)
- 3rd Generation (All-Optical Networks)

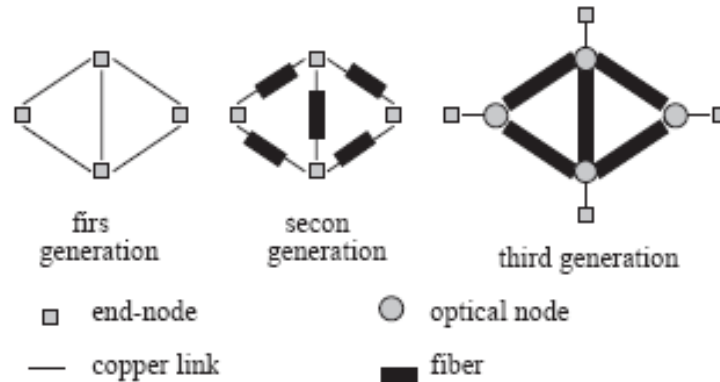

Figure 1: *Three Generations of Networks*¹

In 1G, the whole network was electronic. Transmission medium was completely based on copper cables (or radio waves), whereas the switching and routing was done through electrical equipment. With the invention of optical fibers as means of transmission medium for telecommunication signals, 2G networks exploited the high bandwidth and availability of fiber in the access network, while the core (switching and routing) still remained in the electrical domain. Although the huge bandwidth provided by optical fiber improved network bandwidth to a large extent, it also invited the application developers to introduce new features which were more bandwidth demanding. Soon the electronic core proved to be the bottleneck of the networks and full capacity of fiber optics could not be exploited. This led to

¹ Altan Kocygit, Demeter Gokisik, Semih Bilgen "All-Optical Networking", *Electrical and Electronics Engineering Department, Middle East Technical University, 06531 Ankara, TURKEY*, Turk J Elec Engin, VOL.9, NO.2 2001, C TU"BI_TAK

the concept of third generation of networks called all-optical networks. In this network, unlike its predecessors, the signal throughout end-to-end transmission remains optical. All switching and routing is done completely by optical devices.

3.3 Conclusion

We discussed three generations of telecommunications networks. The first stage was based only on copper, the second stage exists in today's telecom networks as 'some fiber' and the third generation future networks, when everything will be in the optical domain. We will discuss the third generation of communication networks throughout this text.

4. Optical Components Leading to AONs

4.1 Introduction

The devices that enabled the realization of all-optical networks in WDM environment are discussed in this section. These devices are responsible for end-to-end transmission of optical signals, ensuring the signal remains optical throughout.

4.2 Light Sources

The journey of an optical signal starts with the optical light source. It originates the light signals tuned to a particular wavelength, and directs it on the fiber link at a particular angle.

A good light source in communications is referred to as the one that has a wide range of wavelengths to which it can be tuned [8]. Also it should have a lower power consumption and

price to make it more commercially feasible and attractive [8] [16]. Tuning time is a very important factor of light sources. The source should be fast enough to avoid any bottlenecks. Generally, for packet switching, a faster light source is required as compared to circuit switching [8]. Various light sources are available, each with different characteristics and technology. A choice of a particular light source depends on the application it will be used for. Typically, tuning range (width of available wavelengths) and tuning time are the most important parameters to consider.

4.3 Optical Fiber

Starting off with most important, and the base of, an optical network, an optical fiber is either a glass or plastic hair-like fiber that is designed in such a way that enables it to carry light waves along its length. The light waves form electromagnetic carrier waves that are modulated to carry useful information. Use of fiber optics in communication technology has enabled transmission over longer distances and at higher than normal rates.

There are three layers in a single strand of fiber, namely:

- **Core:** is the innermost layer and is made up of Silica and a doping material. This is the layer that carries the light signal. A light wave once entering the fiber stays in the core by the phenomenon, '*total internal reflection, n*' in which the light wave reflects back inside the core after coinciding with the high refractive index material.

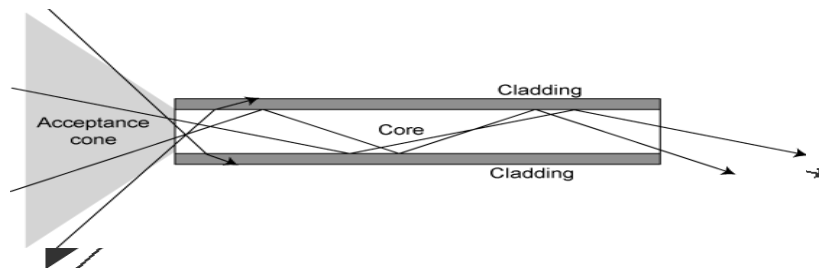

Figure 2: Propagation of Light through an Optical Fiber.²

- **Cladding:** is made up of pure silica and provides the high refractive index material that makes the light wave stay in the core.
- **Coating:** is the external covering material that protects the glass inside. It is usually made of acrylate (plastic).

Transmission of optical signals through a fiber is accomplished by total internal reflection. This phenomenon occurs when a light wave from rare medium (having low refractive index – core) enters the denser medium (high refractive index – cladding), and it is deviated away from normal (Figure 3). By increasing the incident angle, the corresponding refractive angle also increases. The incident angle at which the corresponding refractive angle is 90° is called ‘critical angle’, any angle greater than critical angle will result in light reflecting back into the rarer medium, thus resulting in total internal reflection.

² <http://en.wikipedia.org/wiki/Image:Optical-fibre.png>

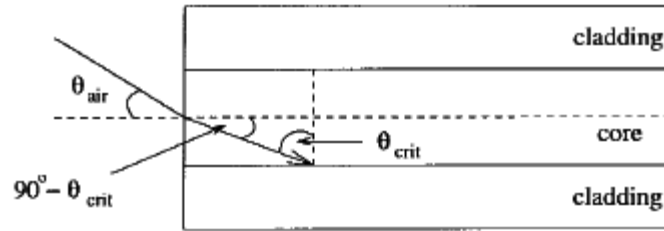

Figure 3: Total Internal Reflection in Optical Fibers.³

The critical angle can be mathematically expressed as

$$\theta_{crit} = \sin^{-1} \left(\frac{n_{clad}}{n_{core}} \right).$$

Equation 1: Critical angle - Snell's Law.⁴

Where,

n_{clad} is refractive index of cladding

n_{core} is the refractive index of core

θ_{crit} is the critical angle

Total internal reflection is achieved when

$$\theta_{crit} > \sin^{-1} \left(\frac{n_{clad}}{n_{core}} \right).$$

Equation 2: Condition for Total Internal Reflection⁵

³ M.S. Borella, J.P. Jue, D. Banerjee, B. Ramamurthy, B. Mukherjee, "Optical Components for WDM Lightwave Networks," *Proceedings of the IEEE*, vol. 85, no. 8, pp. 1274-1307, August 1997.

⁴ M.S. Borella, J.P. Jue, D. Banerjee, B. Ramamurthy, B. Mukherjee, "Optical Components for WDM Lightwave Networks," *Proceedings of the IEEE*, vol. 85, no. 8, pp. 1274-1307, August 1997.

⁵ M.S. Borella, J.P. Jue, D. Banerjee, B. Ramamurthy, B. Mukherjee, "Optical Components for WDM Lightwave

Fiber optic cable is selected because of its vast advantages over other transmission media. Because the transmission media is optic, therefore, more information can travel and that too, with the speed of light plus optical pulses, are immune to electromagnetic interference (EMI) and Radio Frequency Interference (RFI). It is not corroded by atmospheric conditions and offers a very low BER (Bit Error Rate) of the order of 10^{-11} . Fiber is flexible, and because it is made with the cheapest resource on earth, i.e., sand, it is environmental friendly; unlike copper it doesn't deplete natural resources. The only limiting factor for the bandwidth of an optical fiber is dependent on the equipment that lights the fiber (e.g., laser).

4.3.1 Single-Mode Vs Multimode Fiber

There are multiple ways that an optical signal can travel through the fiber; each of these ways corresponds to a particular mode. These modes are determined by the incident angle of the optical beam. Ideally, total internal reflection can occur at any angle greater than the critical angle, but light may not propagate through the fiber at all these angles. The reason is that, some incident angles result in destructive interference, which doesn't allow light to propagate. At other angles, it will cause constructive interference, which allows the light to propagate.

All the angles that allow propagation of light through the fiber result in a specific mode. The fiber that allows propagation of multiple modes of light is called a multimode fiber, and

Networks," *Proceedings of the IEEE*, vol. 85, no. 8, pp. 1274-1307, August 1997.

consequently the one that allows only one mode is single-mode fiber. Generally, fibers of thicker core are multimode.

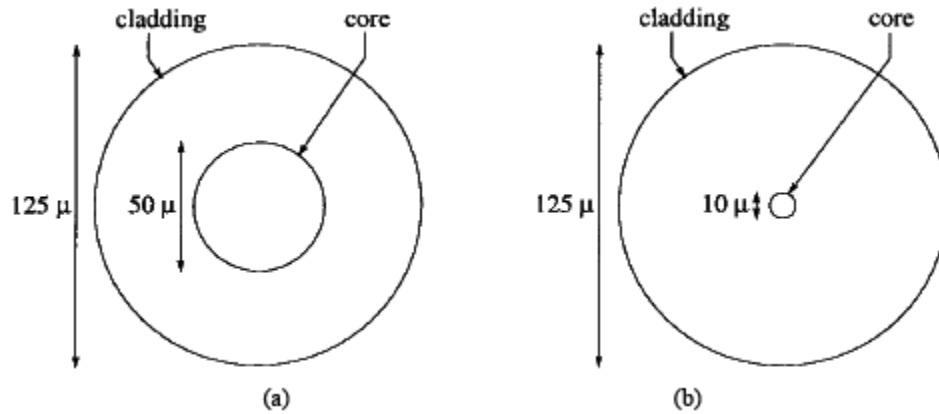

Figure 4: (a) Multimode Fiber (b) Single Mode Fiber.⁶

One of the advantages of multimode fibers is that light could be injected easily on bigger core and allow lesser coupling loss (the amount of power lost when the light is injected into the core), for example, through an LED.

The following equation shows the number of modes, m in a multimode fiber:

$$m \approx \frac{1}{2}V^2.$$

Equation 3: Number of modes in a multimode fiber.⁷

where,

V is the normalized frequency which is given by:

⁶ M.S. Borella, J.P. Jue, D. Banerjee, B. Ramamurthy, B. Mukherjee, "Optical Components for WDM Lightwave Networks," *Proceedings of the IEEE*, vol. 85, no. 8, pp. 1274-1307, August 1997.

⁷ M.S. Borella, J.P. Jue, D. Banerjee, B. Ramamurthy, B. Mukherjee, "Optical Components for WDM Lightwave Networks," *Proceedings of the IEEE*, vol. 85, no. 8, pp. 1274-1307, August 1997.

$$V = k_0 a \sqrt{n_{\text{core}}^2 - n_{\text{clad}}^2}$$

Equation 4: Normalized frequency.⁸

where,

$$k_0 = 2\pi/\lambda,$$

a is the core radius,

λ is the wavelength of light in a vacuum.

The main drawback of multimode fiber is the introduction of intermodal dispersion. This result is due to the difference in velocities of light for each incident angle; thus instead of a sharp beam, multiple light rays are received at the far end, all separated in the time domain. This effect increases with the distance between the two ends, thus offering a lower bit rate.

From Equation 3 and Equation 4, we see that the intermodal dispersion can be reduced by decreasing the number of modes which can be reduced by decreasing the core radius, reducing numerical aperture and/or increasing the wavelength of light.

With the invention of single mode fiber with a very small diameter of core [Figure 4(b)], the problem of intermodal dispersion has been overcome. It allows only a single beam of light to travel through, thus the signal can travel larger distances with limited signal loss. The invention of single mode fibers is one breakthrough that paved the way towards all-optical networks. The only problem with single mode fiber is difficulty in injection of light into a

⁸ M.S. Borella, J.P. Jue, D. Banerjee, B. Ramamurthy, B. Mukherjee, "Optical Components for WDM Lightwave Networks," *Proceedings of the IEEE*, vol. 85, no. 8, pp. 1274-1307, August 1997.

very thin core. Thanks to the invention of lasers, this problem has been overcome to quite an extent, further smoothing the way to all-optical networks.

4.4 All-Optical Wide-Band Amplifiers

Optical amplification is different from electro-optical amplification. Optical amplification is considered 1R (regeneration), whereas electro-optical is 3R (regeneration, re-clocking, reshaping). All optical amplification provides complete data transparency that is the desired property for future's all-optical networks. 3R amplification tends to slow down the system's overall performance due to lack of transparency, which makes it less practical for future optical networks with higher bit rates.

In electro-optical WDM systems, each wavelength must be separated for amplification in electrical domain and then recombined before further transmission. Electro-optical WDM systems need multiplexers and de-multiplexers, whereas optical amplification can amplify the entire WDM signal at once. Optical amplifiers use the concept of stimulated emission. Two popular types of optical amplifiers are semi-conductor laser amplifier and rare-earth doped fiber amplifiers.

4.4.1 Semi-conductor Laser Amplifier

These types of optical amplifiers make use of an adapted semi-conductor laser (Figure 5). Amplification is done by sending in a weak signal through the active region. Stimulated emissions are used to get a stronger signal that is then sent out for transmission.

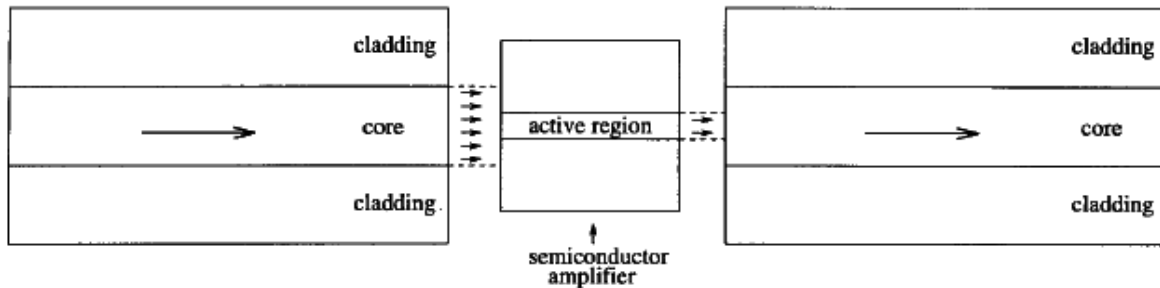

Figure 5: A semiconductor optical amplifier.⁹

4.4.2 Doped Fiber Amplifier

These amplifiers exist within the lengths of fiber by adding an impurity (rare earth element) which has a natural tendency of light amplification. Erbium is the most common rare earth element used, which amplifies wavelengths of 1525 – 1560 nm. A strong signal is injected at fiber end having lower wavelength (known as *pump wavelength*) which excites the rare earth doping element. When data signal passes through these excited atoms, they stimulate them to release photons which results in an amplified signal. This amplified signal is then normally transmitted through the remainder of the fiber. These dopant elements are added throughout the lengths of fibers at various intervals, thus providing optical amplifications as needed.

⁹ M.S. Borella, J.P. Jue, D. Banerjee, B. Ramamurthy, B. Mukherjee, "Optical Components for WDM Lightwave Networks," *Proceedings of the IEEE*, vol. 85, no. 8, pp. 1274-1307, August 1997.

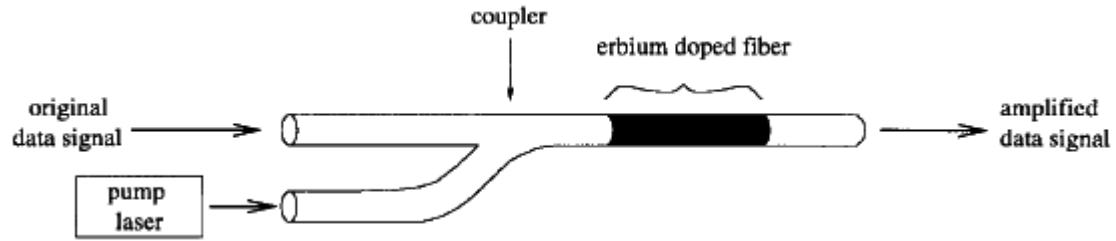

Figure 6: Erbium doped fiber amplifier.¹⁰

4.5 Optical Couplers

Optical couplers are the devices that split light out of the fiber or combine light into the fiber.

Splitters are the type of couplers that split the light out of the fiber into 2 or more fibers. The

reverse of a splitter is a combiner which combines light from 2 or more fibers into 1. Most

common types of splitters are 1 x 2 [Figure 7(a)], common combiners are the reverse of this,

i.e., 2 x 1 [Figure 7(b)]. A 2 x 2 coupler is simply a 2 x 1 combiner and then 1 x 2 splitter

[Figure 7(c)].

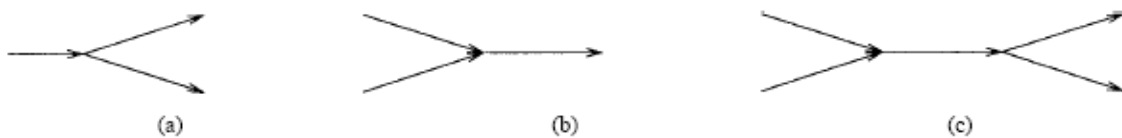

Figure 7: (a) Splitter, (b) combiner and (c) coupler.¹¹

¹⁰ M.S. Borella, J.P. Jue, D. Banerjee, B. Ramamurthy, B. Mukherjee, "Optical Components for WDM Lightwave Networks," *Proceedings of the IEEE*, vol. 85, no. 8, pp. 1274-1307, August 1997.

¹¹ M.S. Borella, J.P. Jue, D. Banerjee, B. Ramamurthy, B. Mukherjee, "Optical Components for WDM Lightwave Networks," *Proceedings of the IEEE*, vol. 85, no. 8, pp. 1274-1307, August 1997.

4.6 Tunable lasers (transmitters)

These lasers are such that their wavelengths can be tuned as desired before transmitting. Important factors to consider for tunable lasers are the tuning time (the time it takes to tune a laser to the desired wavelength), tuning range (range of wavelengths) and whether the laser can be tuned continuously within its range or whether only certain wavelengths can be achieved discretely.

4.7 Tunable Filters (receivers)

Tunable optical receivers or filters are another category of devices that made WDM all-optical networks a reality. Tunable optical filters are the ones that can pick a particular frequency out of WDM signal. Tuning time and tuning range are important characteristics of filters in WDM system. The range shows the number of possible channels that could be filtered by the receiver. Tuning time and range become very important in scenarios like WDM network when deployed with broadcast and select architecture.

4.8 Optical Switching

Current switching technique used in optical networks involves electro-optical conversions. Whenever a signal through high-capacity fiber reaches a switch/router, before any processing is done, the signal is converted back to its native state (electrical). Although electrical switches are far more efficient, flexible and advanced and have high processing capabilities, they are no match to the high speed and bandwidth of the light. Moreover, because of an

added electro-optical conversion each time the signal hits a switching device it results in added delay and overhead to the whole system. This further limits the overall performance of the system. Because of these reasons, an all-optical network concept has started to gain pace. It has optical switching devices that are able to process and route data without having to do any electro-optical conversions.

The control functions for switching in current optical-switching devices are still performed in electronic domain but the data signals stay optical throughout. This means that the optical signal is transparent to the switch and the switch is unaware of the signal format and its data rate. Wavelength-dependant switches are also being developed for WDM networks.

All optical switches can be broadly classified into two main classes as discussed below.

4.8.1 Relational Switches

This class of switches institutes a relationship of the inputs with outputs. This relationship is a control function of the switch and is not dependant on the actual input signal. The switch performs the same control function or set of control functions irrespective of the input. Directional couplers are one example of this class of switches. They perform either splitting or combining irrespective of the data carried by the signal. Switches belonging to this class can allow higher data rates as they cannot sense individual bits of the optic signal, instead as a single continuous stream. This is called *data transparency*. Depending on the situation, this characteristic can either prove to be beneficial or sometimes detrimental, as it reduces

flexibility since the individual portions of the signal cannot be sensed by the device and thus cannot be switched.

Some of the commonly used relational switches are discussed below.

a. Optical Cross-connects

An optical cross-connect switches incident signals from input to the output. This switch is considered to be wavelength independent because it cannot sense the wavelengths of incident signal and cannot provide any de-multiplexing functionality. One of the very basic and common optical cross connects is the 2 x 2 cross connect (Figure 8). It routes two input signals to two output signals with 2 states; cross and bar. When the switch is in bar state, both inputs follow the straight path to the output, i.e., input 1 to output 1 and input 2 to output 2 [Figure 8(a)]. When the state is cross, the two input signals are swapped at the output, i.e., input 1 becomes output 2 and input 2 becomes output 1 [Figure 8(b)].

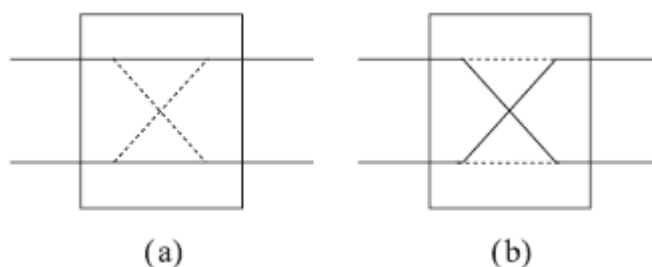

Figure 8: 2 x 2 optical cross-connect (a) bar and (b) cross state.¹²

¹² M.S. Borella, J.P. Jue, D. Banerjee, B. Ramamurthy, B. Mukherjee, "Optical Components for WDM Lightwave Networks," *Proceedings of the IEEE*, vol. 85, no. 8, pp. 1274-1307, August 1997.

b. Non-reconfigurable wavelength routers

Wavelength routing is an important aspect of WDM networks. In a wavelength router a mixture of wavelength received at one port is de-multiplexed into individual wavelengths. This router can send each wavelength to designated port where different wavelengths received can be recombined through a multiplexer into a WDM signal. The word non-reconfigurable refers to the phenomenon that, when signal is split into its constituent wavelengths, there are pre-defined fixed routes that a particular wavelength needs to follow. There is no switching process during this stage. A non-reconfigurable wavelength router is shown in the figure below.

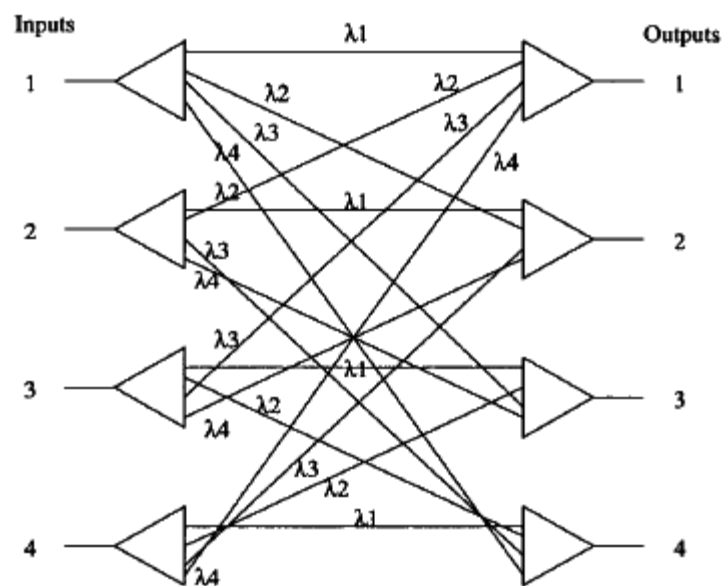

Figure 9: A 4 x 4 non-reconfigurable wavelength router.¹³

¹³ M.S. Borella, J.P. Jue, D. Banerjee, B. Ramamurthy, B. Mukherjee, "Optical Components for WDM Lightwave Networks," *Proceedings of the IEEE*, vol. 85, no. 8, pp. 1274-1307, August 1997.

The decision of wavelengths forwarding to a particular port is pre-determined through a matrix. This matrix is achieved through making permanent connections between de-multiplexers and multiplexers.

c. Reconfigurable wavelength router

This type of router offers greater flexibility in routing. In this scheme a WDM signal received at a certain port is de-multiplexed into individual wavelengths. There is an array of switches in column next to de-multiplexers as shown in the figure, each corresponding to a particular wavelength. The switches can route a particular wavelength to a particular port. All wavelengths received at a particular port are recombined into a WDM signal again. It is interesting to note that each switch is a relational device, basically a 2x2 cross point element receiving a fixed wavelength. This switch can be re-configured to a different wavelength through tuning. Therefore, the overall routing is based upon the actual wavelength of the signal and mode of the switch at which it is configured currently.

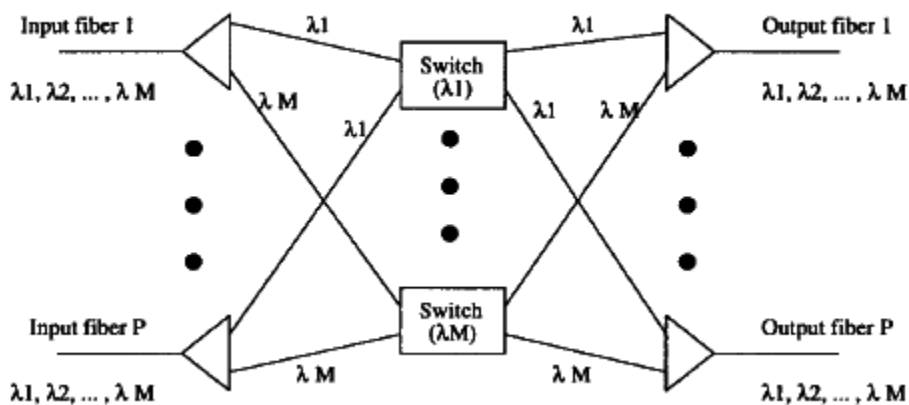

Figure 10: A $P \times P$ reconfigurable routing switch with M wavelengths.¹⁴

4.8.2 Logic Switches

These are the switches that interpret the data stream incident on the input, then process according to the information it carries and switch accordingly. The signal at the input controls the state of the switch such that some Boolean functions are performed on it. Since the device is interpreting the bits in the data and changing states accordingly, it should be fast enough to pace itself with the input data rate (or faster). This causes a limit on the data rate of the incident signal, although it does give the switch some additional flexibility.

Below we discuss some commonly used logic switches.

4.9 Photonic packet switches

The components discussed above are relational, i.e., they follow a pre-defined path for forwarding the packets. Such components are suitable in circuit-switched networks. For greater flexibility and scalable networks we need components in AONs that can perform

¹⁴ M.S. Borella, J.P. Jue, D. Banerjee, B. Ramamurthy, B. Mukherjee, "Optical Components for WDM Lightwave Networks," *Proceedings of the IEEE*, vol. 85, no. 8, pp. 1274-1307, August 1997.

some logical decisions on packets. In these types of switches the forwarding is based on the content of the packet instead of some pre-defined mechanism. Whenever there is any type of logical decisions, the device switch becomes a constraint recourse. Many packets may arrive before being able to be sent to the output port. This type of problem is easily solved in electronic domain by introducing buffer in switches and routers. Saving electrical data for some time is achieved through a series of flip-flops. But the problem of keeping data in buffers when it is in optical domain is still somewhat challenging. There are some solutions proposed for optical buffering, e.g., long rings of fibers may be introduced in the switching devices to create an artificial delay. An example of optical packet switch is Content Resolution by Delay lines (CORD) as shown in the figure below. By careful calculation of delays, the power and packet loses could be reduced to a minimum.

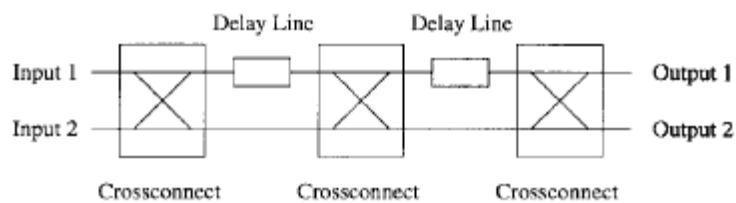

Figure 11: *The CORD architecture.*¹⁵

4.10 Wavelength conversion

In WDM networks each fiber carries a number of wavelengths. The devices' cross-connects are responsible for transmitting the signal onwards either by routing the same wavelength to a different port or by wavelength conversion. The optical switch treats each wavelength signal

¹⁵ M.S. Borella, J.P. Jue, D. Banerjee, B. Ramamurthy, B. Mukherjee, "Optical Components for WDM Lightwave Networks," *Proceedings of the IEEE*, vol. 85, no. 8, pp. 1274-1307, August 1997.

individually. Wavelength selective cross-connect (WSXC) as shown in the figure 12(a) is capable of sending a signal received on port and send it on to some other port.

Wavelength interchange cross-connect (WIXC) as shown in figure 12(b) is a device that carries out the operation of wavelength conversion. It is with the help of this cross-connect that the problem of ‘wavelength continuity constraint’ – which means the light paths needed to maintain the same wavelength all the way along the fiber, is resolved. It helps use network resources more efficiently. WIXC is a complex device and offers greater flexibility to the network model [33].

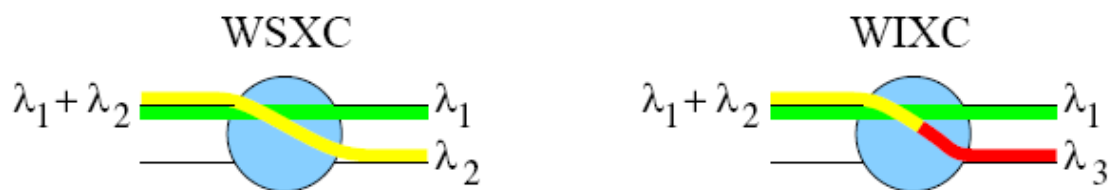

Figure 12: a) *Wavelength selective cross-connect* and) *wavelength Interchanging cross connect*¹⁶

4.11 Conclusion

In this chapter we discussed optical components that led to the concept of all-optical networks. Most important network components like light source, wide band amplifiers, optical switches and routers, tunable transmitters (lasers) and receivers are discussed. It is

¹⁶ Esa Hyyti's thesis "Dynamic Control of All-Optical WDM Networks" Supervisor: Professor Jorma Virtamo, HUT ,HELSINKI UNIVERSITY OF TECHNOLOGY Department of Electrical and Communication Engineering Networking Laboratory [online] available at http://www.netlab.tkk.fi/tutkimus/cost257/publ/thesis/thesis_esa_01.pdf

through the discovery of these optical components that all-optical networks could become a reality.

5. Multiplexing Techniques in AONs

5.1 Introduction

To fully utilize the vast bandwidth of optical fiber, concurrency can be initiated between various users' transmission. This phenomenon is called multiplexing. In this section we discuss various multiplexing techniques that are employed in all-optical networks.

5.2 OTDM – Optical Time Division Multiplexing

In this type of multiplexing, a single high-speed transmission channel on fiber contains numerous ultra-short pulses that are time interleaved. These ultra-short pulses make up the numerous low-speed user channels. By applying this multiplexing, a single fiber can be exploited to transmit data between multiple users/nodes, thereby increasing the network capacity by many folds. Since these short pulses are carrying all the information from one end to another, both the transmitters and receivers should be perfectly synchronized to the exact same channel (time slot) to make sure there is no interference.

5.3 CDM – Code Division Multiplexing

In this type of concurrent transmission technique, each channel is allocated a unique code. Various channels are projected onto the optical fiber. Signals are distinguished through their

unique codes. The range of codes is kept large to avoid a co-relationship between different signals travelling over the same fiber. The overall network capacity with this approach is huge allowing full utilization of fiber capacity. The restriction of synchronization at both ends is crucial in CDM technology as well.

5.4 WDM – Wavelength Division Multiplexing

In WDM, the wavelength of the light waves is exploited to carry multiple data streams on a single fiber. The existing spectrum of light (in its useable range 1300–1550 nm) is divided into multiple channels, each supporting the data rate higher than the peak electronic data rate. As a result the overall network capacity increases by the rate of each channel times the number of channels. Since each sending and receiving end can send multiple channels, multiple wavelengths are required. This is the reason tunable transmitters and receivers are required at both ends.

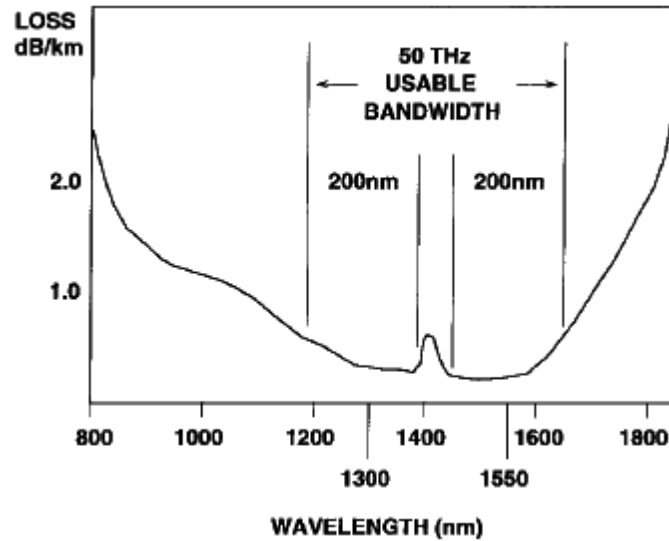

Figure 13: The low attenuation region of optical fiber.¹⁷

WDM is more popular than CDM or OTDM because of their complex requirements of hardware and synchronization. Moreover, the hardware required for WDM is commercially more available. The property of transparency of WDM also makes it a choice for present day AONs.



Figure 14: Block diagram of a WDM transmission system.¹⁸

Above figure (Figure 14) shows the block diagram of generic WDM network. A simple fiber link can make up the network medium. The transmitter consists of either a laser or a

¹⁷ M.S. Borella, J.P. Jue, D. Banerjee, B. Ramamurthy, B. Mukherjee, "Optical Components for WDM Lightwave Networks," *Proceedings of the IEEE*, vol. 85, no. 8, pp. 1274-1307, August 1997

¹⁸ M.S. Borella, J.P. Jue, D. Banerjee, B. Ramamurthy, B. Mukherjee, "Optical Components for WDM Lightwave Networks," *Proceedings of the IEEE*, vol. 85, no. 8, pp. 1274-1307, August 1997

modulator. In case of multiple wavelengths, a coupler is required to unite the wavelengths to be transmitted on a single optical fiber. Likewise, an optical de-multiplexer is required at the receiver end to separate different wavelengths, which are then directed to a photodiode array. Tunable laser can also be used to transmit a single wavelength and in this case, a tunable filter is also required at the receiving end to filter the desired wavelength.

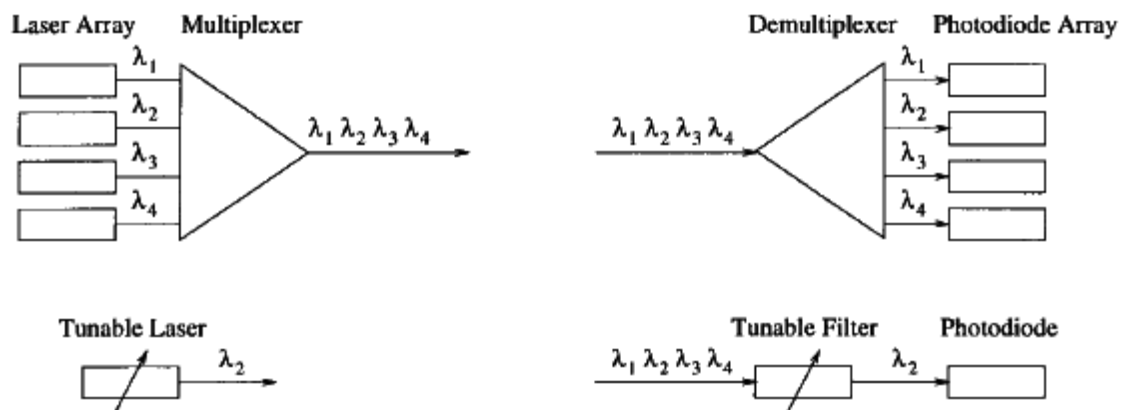

Figure 15: Transmitter and receiver structures.¹⁹

5.5 Conclusion

In this section we discussed three popular types of multiplexing that are used in all-optical networks. The concepts of Optical time division multiplexing (TDM), Code division multiple access (CDMA) and Wavelength division multiplexing (WDM) are discussed.

¹⁹ M.S. Borella, J.P. Jue, D. Banerjee, B. Ramamurthy, B. Mukherjee, "Optical Components for WDM Lightwave Networks," *Proceedings of the IEEE*, vol. 85, no. 8, pp. 1274-1307, August 1997

6. Architectural Forms of WDM Networks

6.1 Introduction

There are several architectural forms of WDM networks. Each has its own advantages and disadvantages. In this section we will discuss some of the most common forms of WDM networks. Basic architecture of each WDM network, its limitations in implementation and advantages and disadvantages are discussed.

6.2 WDM Links

In second generation networks (2G - Figure 1), there are several parallel fibers introduced between two end nodes; each fiber is designated for a single channel. The WDM link network is practically an upgraded version of that. In this network, a single-fiber link replaces all the parallel fibers. The different channels previously going on separate fibers are now multiplexed on the single fiber using different wavelengths (Figure 16). All channels are now amplified using a single-wide-band optical amplifier unlike 2G networks where each channel required a separate amplifier. This increases overall system's cost efficiency and the existing fibers are now being exploited proficiently.

WDM Link networks are popular because they are less costly and simpler to integrate with already running networks, and the technology is more mature.

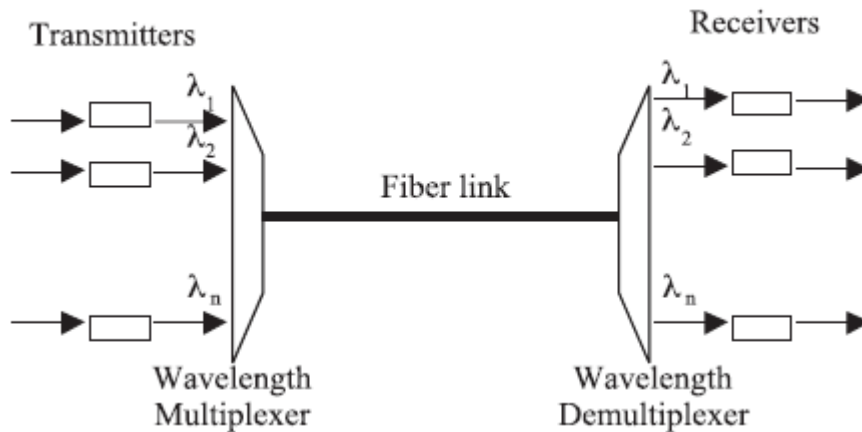

Figure 16: WDM Link.²⁰

6.3 Passive Optical Networks (PON)

The term ‘passive’ signifies the use of unpowered equipment in the network that doesn’t require electrical input. These include optical fiber itself, couplers (star and directional), filters and passive routers. This type of network is generally designed for small distance communications, typically 20 to 30 miles or less. Since the optical signals are travelling only a short distance, there is no impacting attenuation; therefore, no signal amplification is required. This approach is as inviting as it is low cost and provides high bandwidth and reliability, and for this reason are highly preferred when designing LANs or MANs.

PONs are commonly used for connecting various *Optical Network Units (ONUs)* at customer premises to the *Central Office (CO)* through optical fiber pairs to enable bi-directional transmission. CO is responsible for all routing in PONs.

²⁰ Altan Kocygit, Demeter Gokisik, Semih Bilgen “All-Optical Networking”, *Electrical and Electronics Engineering Department, Middle East Technical University, 06531 Ankara, TURKEY*, Turk J Elec Engin, VOL.9, NO.2 2001, C TU-BI-TAK

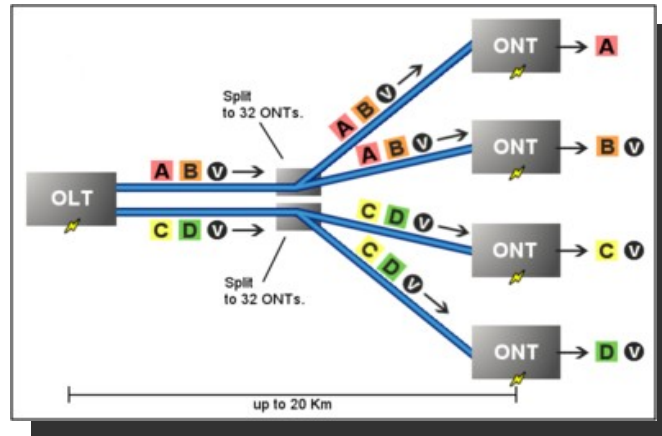

Figure 17: A Typical Passive Optical Network (PON)²¹

PONs can use all popular LAN and MAN topologies like bus, star, tree and ring. Also, they may be employed in Fiber-to-the-Home/Curb/Building (FTTH/C/B). Different PONs can become parts of the bigger network that might have active elements in the network. In that case, they can also be used for Point to Multipoint (P2MP) communications, connecting various sub networks to the backbone.

The only technological drawback of PONs is ONUs' design. Since they are at customer premises, they should be durable enough to withstand natural and unnatural disasters, yet cheap and simple to enable integration with pre-existing networks.

²¹ http://en.wikipedia.org/wiki/Fiber_to_the_premises

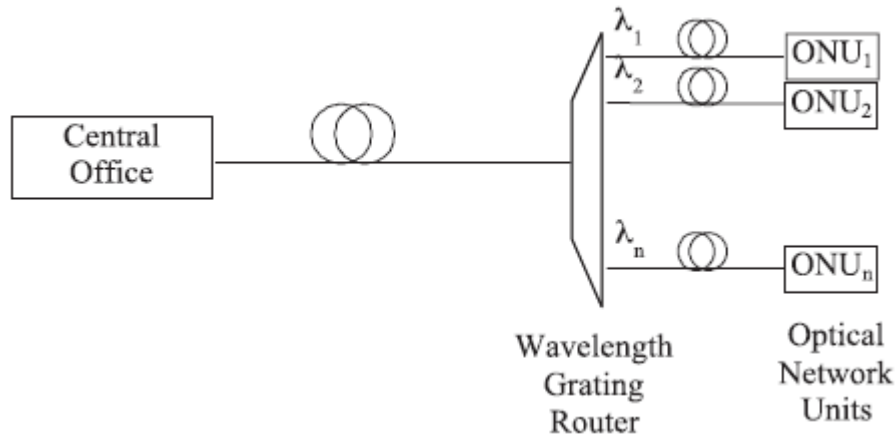

Figure 18: PON, connecting CO and ONUs.²²

6.4 Broadcast and Select Network

This most simple type of all optical WDM networks makes use of couplers. Various transmitters send data on distinct wavelengths. These wavelengths are combined in a combiner and aggregate signal is sent to each receiver. As shown in the diagram below, in the first stage all the signals are combined and the splitter sends the copy of this signal to all the users. Receiving end uses tunable receivers to get the wavelength intended for it.

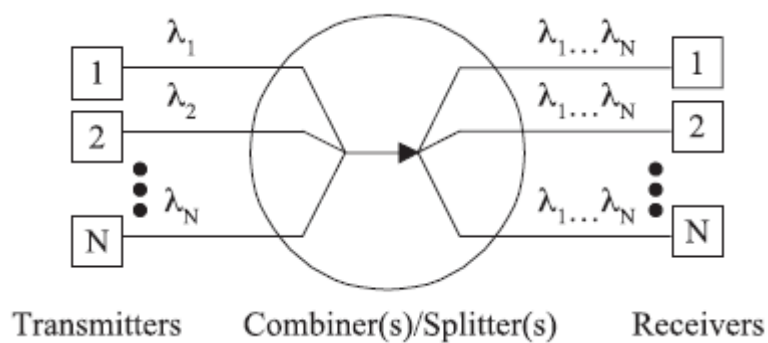

Figure 19: WDM network with combiner/splitter²³

²² Altan Kocygit, Demeter Gokisik, Semih Bilgen "All-Optical Networking", *Electrical and Electronics Engineering Department, Middle East Technical University, 06531 Ankara, TURKEY*, Turk J Elec Engin, VOL.9, NO.2 2001, C TU-BI-TAK

6.4.1 Physical topologies in Broadcast and select network

Different physical topologies of WDM broadcast and select network are utilized.

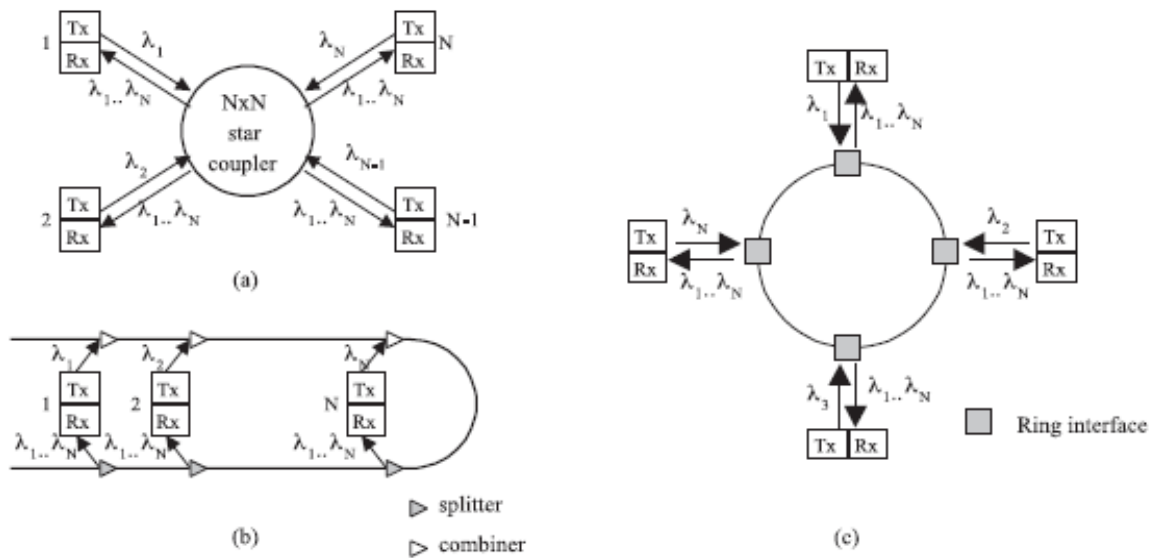

Figure 20: Broadcast and Select Organizations: a) Star b) Bus c) Ring.²⁴

d. Star WDM Architecture

The topology shown in Figure 20(a) consists of a passive star coupler, the most common and simplest type architecture of broadcast and select networks. The network in star WDM consists of an ‘ $N \times N$ ’ star coupler which is completely a glass body and is positioned in the centre. All nodes of the network that are part of this topology are connected by means of fiber pairs to the inputs and outputs of this coupler. The power of input optical signal in this approach is distributed evenly amongst the outputs. For example, the input signal on an ideal

²³ Altan Kocygit, Demeter Gokisik, Semih Bilgen “All-Optical Networking”, *Electrical and Electronics Engineering Department, Middle East Technical University, 06531 Ankara, TURKEY*, Turk J Elec Engin, VOL.9, NO.2 2001, C TU*BI_TAK

²⁴ Altan Kocygit, Demeter Gokisik, Semih Bilgen “All-Optical Networking”, *Electrical and Electronics Engineering Department, Middle East Technical University, 06531 Ankara, TURKEY*, Turk J Elec Engin, VOL.9, NO.2 2001, C TU*BI_TAK

$N \times N$ star coupler will be transmitted equally to all the output ports. The output power at each port will then be $P_{out} = P_{in}$, which is the same on all the output ports.

e. Bus WDM Architecture

In WDM bus architecture, pairs of combiners and splitters are connected to each end node separately and the fiber makes the bus topology. The nodes will receive data on the fiber using splitters and transmit their own to the fiber using combiners as shown in Figure 20(b). Amongst star and bus topology, efficiency of star topology is better than that of bus because it distributes optical power evenly, whereas in case of bus WDM network, each node receives power of different level.

f. Ring WDM architecture

Ring architecture is created by connecting all end nodes to the central fiber ring [Figure 20(c)]. Each node is connected to the fiber via a pair of combiner and splitter. For each node in this network, a unique wavelength is selected and transmitted, which is received by the tunable receivers that generally detect all available wavelengths in the network. Splitters are installed in the central fiber ring for a node to enable it to receive its data. When the node wants to send something, small combiners inject the data back into the fiber ring. If a signal is already in the ring, filters are inserted just before the combiner that filter out the previous info. As far as the optical power distribution efficiency is concerned, star topology is still more efficient than ring topology. Enhancing the ring topology by adding another parallel

ring and making both rings transmit information in opposite directions can make it more fault tolerant.

6.4.2 WDM broadcast and select network advantages/disadvantages

Advantages: Broadcast and select WDM networks as discussed are deployed using passive components which are resistant to environmental conditions, hence failures and outages are avoided. The second important feature of broadcast and select networks is simplicity. Due to presence of passive components in core, intelligence is shifted towards periphery and core is relieved from complex operations.

Disadvantages: This type of network involves broadcasting aggregate signal to all the end users which introduces a splitting loss. There are a maximum number of users that can be hooked to a particular broadcast and select network, as the signal power gets divided into all branches and the signal has to maintain certain strength. This problem can be overcome by adding wide-band amplifiers, which would reduce network's simplicity and also increase network cost [7]. The total number of end users can not be more than the number of available channels. It is not possible to use the same channel in other region of the network. Not being able to re-use a wavelength reduces network throughput and available bandwidth. Low spacing between the channels might increase the total number of available channels but this would require using very fine large range of tunable lasers as light sources and tunable filters for receiving the signal correctly. This type of network is only suitable for smaller networks like LANs and WANs [6], [7].

6.5 Wavelength Routing WDM Networks

Wavelength routed networks, also called WRN, are all-optical networks suitable for large-scale metropolitan networks. As discussed in the limitation of broadcast and select networks, scalability is the main driver of wavelength routing networks. Since there is no concept of wavelength re-use in broadcast and select WDM network, it becomes difficult for the signal to travel over larger distances keeping the same wavelength. The problem of power splitting loss is also present in broadcast and select networks. This also limits the number of users that can hook themselves on the network.

These issues are overcome in wavelength routing networks by introducing the concept of wavelength re-use and by sending the specific signal in a particular link instead of broadcasting, which saves signal power. Wavelength routing networks include wavelength routers and optical fibers connecting them. It is interesting to note that the routers are all-optical, which means no electro-optical conversions are required. The routing is a function of input port for the incoming signal and its wavelength. It is kept in mind that wavelength re-use is possible in wavelength routed networks but no same signals should be placed on same wavelength going through the same fiber at any point. This is known as wavelength continuity constraint. Each start to end path carrying optical signal is called a light path. Wavelength re-use allows a greater amount of signal to be transmitted over a smaller region.

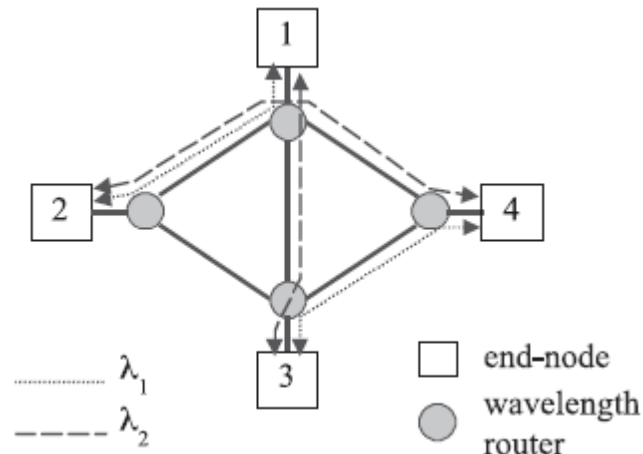

Figure 21: Wavelength routing network.²⁵

There are four types of wavelength routing networks [34].

6.5.1 WRN-Fiber Cross Connect

These networks employ simple and cheap devices called optical cross connects. These devices have two states, namely, bar state and cross state. The state of these devices is configured through electronics. These devices keep the signal transparent. These simple devices can be cascaded into an array and switches can be made. This is not a true wavelength routing but as the number of light paths increases many signals will follow the same route. Thus when deploying large scale networks, a mix of cross connects and wavelength routing devices achieve cost efficiency.

²⁵ Altan Kocygit, Demeter Gokisik, Semih Bilgen "All-Optical Networking", *Electrical and Electronics Engineering Department, Middle East Technical University, 06531 Ankara, TURKEY*, Turk J Elec Engin, VOL.9, NO.2 2001, C TU-BI_TAK

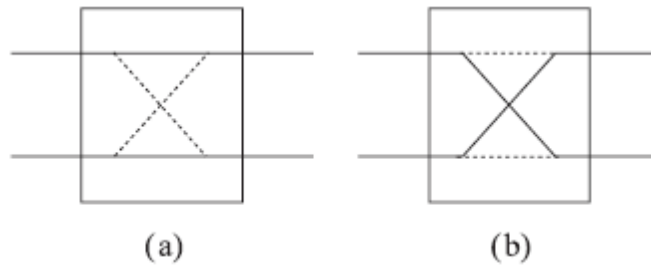

Figure 22: 2×2 Cross Connects, (a) Bar State and (b) Cross State.²⁶

6.5.2 WRN-Add drop Multiplexers

Implementing a wavelength-routed network using add drop multiplexer is still an experimental practice. This device consist of an input port (that receives a mixture of signals), a drop port (where some wavelengths from the input signal are dropped), an add port (where new wavelengths are added to the signal) and out port (to deliver the new signal back to the fiber) [6], [7].

This adds drop functionality can be fixed or tunable. In tunable add drop multiplexer, electronic domain is used to control the wavelength(s) to be dropped or added. One example is ‘*Acousto-optic Tunable Filter (AOTF)*’ as shown in figure 23.

Input signal enters the first block where polarization beam splits the signal into its constituent wavelengths. In the next block, the wavelength to be dropped is injected into polarization converter. In the third block the signal is finally dropped.

²⁶ Altan Kocygit, Demeter Gokisik, Semih Bilgen “All-Optical Networking”, *Electrical and Electronics Engineering Department, Middle East Technical University, 06531 Ankara, TURKEY*, Turk J Elec Engin, VOL.9, NO.2 2001, C TU“BI_TAK

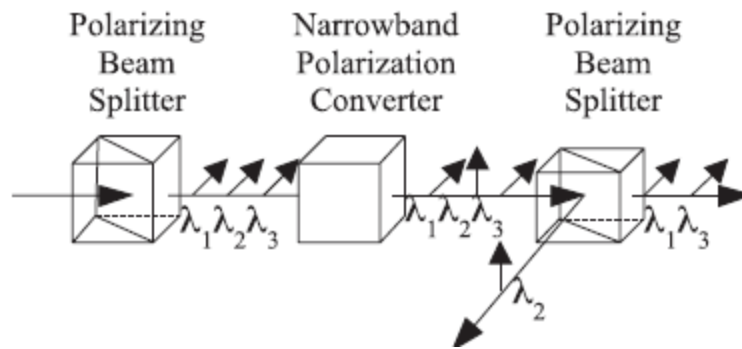

Figure 23: Acousto-optic Tunable Filter.²⁷

6.5.3 WRN-Static wavelength router

This type of arrangement is shown in figure 24. There is an array of de-multiplexers one for each input signal and there is an array of multiplexers at the output line. The series of de-multiplexers divides the input signal into its constituent wavelengths each wavelength is routed towards output multiplexers based on a defined connection. Multiplexer re-combines the signal and directs it towards output ports. It is interesting to observe that this arrangement can be static or dynamic. The routing decision is based on the matrix at the given time.

One example of static wavelength router is WGR. It is a passive component. Due to presence of fixed routing matrix this device offers a lesser flexibility. Some AONs deploy WGR fixed wavelength routing in level 1 network [4], [5].

²⁷ Altan Kocygit, Demeter Gokisik, Semih Bilgen "All-Optical Networking", *Electrical and Electronics Engineering Department, Middle East Technical University, 06531 Ankara, TURKEY*, Turk J Elec Engin, VOL.9, NO.2 2001, C TU-BI_TAK

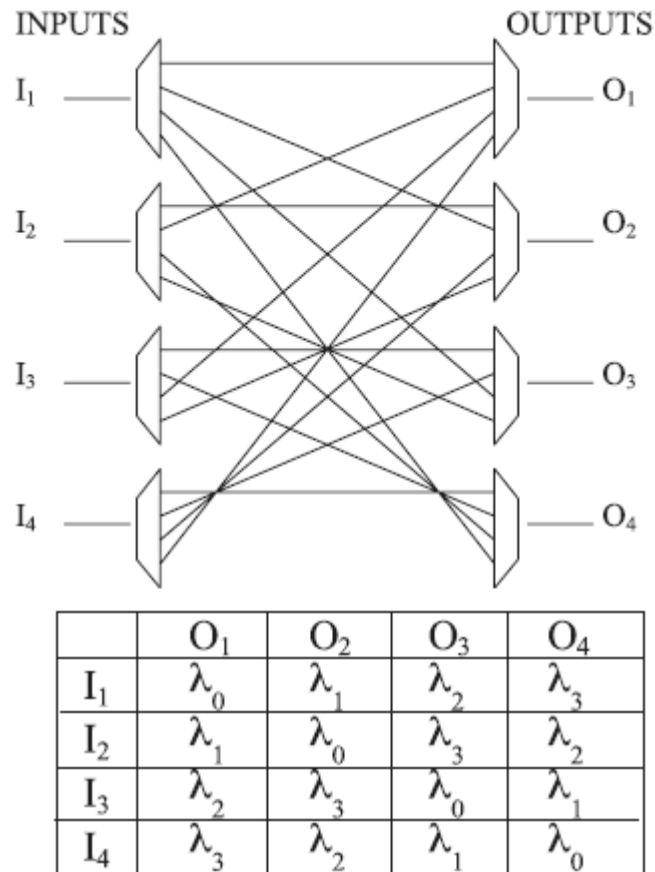

Figure 24: A 4 x 4 static wavelength router and its connections matrix.²⁸

6.5.4 WRN-Reconfigurable wavelength router

Re-configurable wavelength includes configuration options for wavelength routing. There is an array of N de-multiplexers on N input links which breaks the signal into different wavelengths. There is an array of N multiplexers re-combining the signals before sending them on the output ports. A number of photonic switches are placed between de-multiplexers and multiplexers in number W where W is the number of wavelengths. Multiplexers and de-multiplexers are exactly equal to the number of input/output ports. Signals of a particular

²⁸ Altan Kocygit, Demeter Gokisik, Semih Bilgen "All-Optical Networking", *Electrical and Electronics Engineering Department, Middle East Technical University, 06531 Ankara, TURKEY*, Turk J Elec Engin, VOL.9, NO.2 2001, C TU"BI_TAK

wavelength are directed to a specific switch. These switches are made from 2x2 optical cross connects. Different switches are connected to input/output ports in a way that any wavelength coming from any input port can be routed to any output port. Switches mechanism is controlled by electronics but the signal remains optical. Routing decisions at any point depend upon the entries of routing matrix.

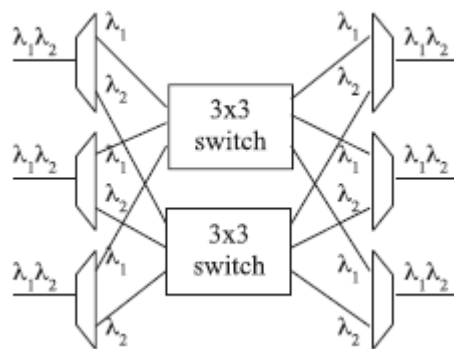

Figure 25: A 3 x 3 reconfigurable wavelength router.²⁹

6.6 Conclusion

In the above section, we discussed the different architectural types of WDM networks. We discussed the implementation of each type, along with its pros and cons. We also highlighted the challenges faced during the implementation of these types and what types of networks are most feasible for each type. WDM networks have to go a long way to reach their ultimate goal, but with the current technological advancements, that goal seems in sight.

²⁹ Altan Kocygit, Demeter Gokisik, Semih Bilgen "All-Optical Networking", *Electrical and Electronics Engineering Department, Middle East Technical University, 06531 Ankara, TURKEY*, Turk J Elec Engin, VOL.9, NO.2 2001, C TU-BI_TAK

7. Types of All-Optical networks

7.1 Introduction

In this section we will discuss three broad categories of all-optical networks. AONs can be implemented in different ways. Depending on the type of nodes used and rate of transmission, they can be classified into the following types [3] [4] [6].

- Passive Optical Networks (PONs)
- Transparent Optical Networks (TONs)
- Ultra-high-speed Optical Networks (UONs)

7.2 Passive Optical Networks (PONs)

The term 'passive' signifies the use of unpowered equipment in the network that doesn't require electrical input. These include optical fiber itself, couplers (star and directional), filters and passive routers. This type of network is generally designed for small distance communications, typically 20 to 30 miles or less. Since the optical signals are travelling only a short distance, there is no impacting attenuation; therefore, no signal amplification is required. This approach is as inviting as it is low cost and provides high bandwidth and reliability. For this reason they are highly preferred when designing LANs or MANs.

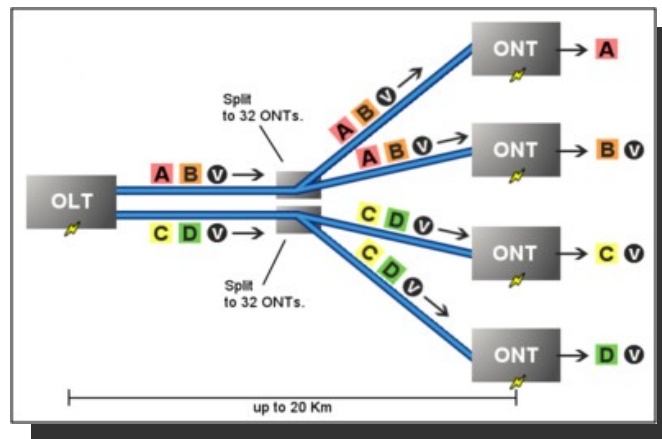

Figure 26: A Typical Passive Optical Network (PON)³⁰

PONs can use all popular LAN and MAN topologies like bus, star, tree and ring. Also, they may be employed in Fiber-to-the-Home/Curb/Building (FTTH/C/B). Different PONs can become parts of the bigger network that might have active elements in the network. In that case, they can also be used for Point to Multipoint (P2MP) communications, connecting various sub networks to the backbone.

7.3 Transparent Optical Networks (TONs)

Transparent Optical Networks (TONs) are optical network that allow signals to transmit without having any impacts from the basic transmission characteristics like data rate and signal modulation. The primary objectives of PONs are high performance, flexibility and extensive coverage both locally as well as globally. At present most of the optical equipment can easily be modified to be independent of these transmission characteristics; however, since

³⁰ http://en.wikipedia.org/wiki/Fiber_to_the_premises

each end-to-end communication can have a different performance criterion for data rates and modulation types, limitations do exist. An ideal form of transparency may never exist in a transparent AON; however, each network can provide this transparency to some extent by making one or more of the transmission characteristics transparent. TONs are, therefore, categorized as follows:

- **1T – Transparent:** Transmission format,
- **2T – Transparent:** Transmission format and clock frequency,
- **3T – Transparent:** Transmission format, clock recovery and line code,
- **4T – Transparent:** Transmission format, clock frequency, line code and modulation format.

7.4 Ultra-High Speed Optical Networks:

This type of AON has a characteristic of using very high-speed optical devices. Ultra-Short optical pulses [4] are generated which are transmitted over long distances. The important technologies required to construct these AONs are generation of ultra short pulses, multiplexing, high-speed transmission of these pulses, optical buffers, clock recovery . Typically, OTDM (Optical Time Division Multiplexing) is used in these AONs. These AONs have high performance, but because of the technology constraints they are not yet mature [4].

7.5 Conclusion

Types of AONs with respect to nodes type, data transmission rate and architecture were discussed in this section. Passive optical networks carry passive optical devices. Transparent

optical networks do not process or manipulate data. Ultra high-speed data networks were also discussed which are still going through the development process and the technology has not yet matured.

8. IP over All Optical Network

8.1 Introduction

In this section, we will discuss the importance of IP in today's communication and will propose how IP and AONs can work together to take advantage of the strengths of both technologies. The purpose is to highlight major challenges and issues in this process.

8.2 IP in Today's Communications

After its initiation in the 70s when it first started as a means of military and campus communication, Internet has now become the centre of all network services. Its huge success is attributed to the scalability, hierarchy, resilience, simplicity and robustness of Internet Protocol (IP), which has, therefore, become the center of networking protocols. Apart from what Internet was originally designed for, there is a variety of services hosted by Internet today which include audio/video telephony, banking, medicine, business, e-commerce, education and entertainment. Thus it is becoming an increasingly unavoidable commodity in human life.

With the recent surge of traffic due to the exponential growth of services as well as the greed for bandwidth at the application layer shrinkage of capacity at the transport layer has resulted. It is expected that this will continue to increase further incorporating those areas which by far have not yet been explored by today's Internet like television, radio and tele-medicine. This high demand of bandwidth hungry applications has led to the requirement of optimization in terms of both physical layer and supporting protocols at the upper layers.

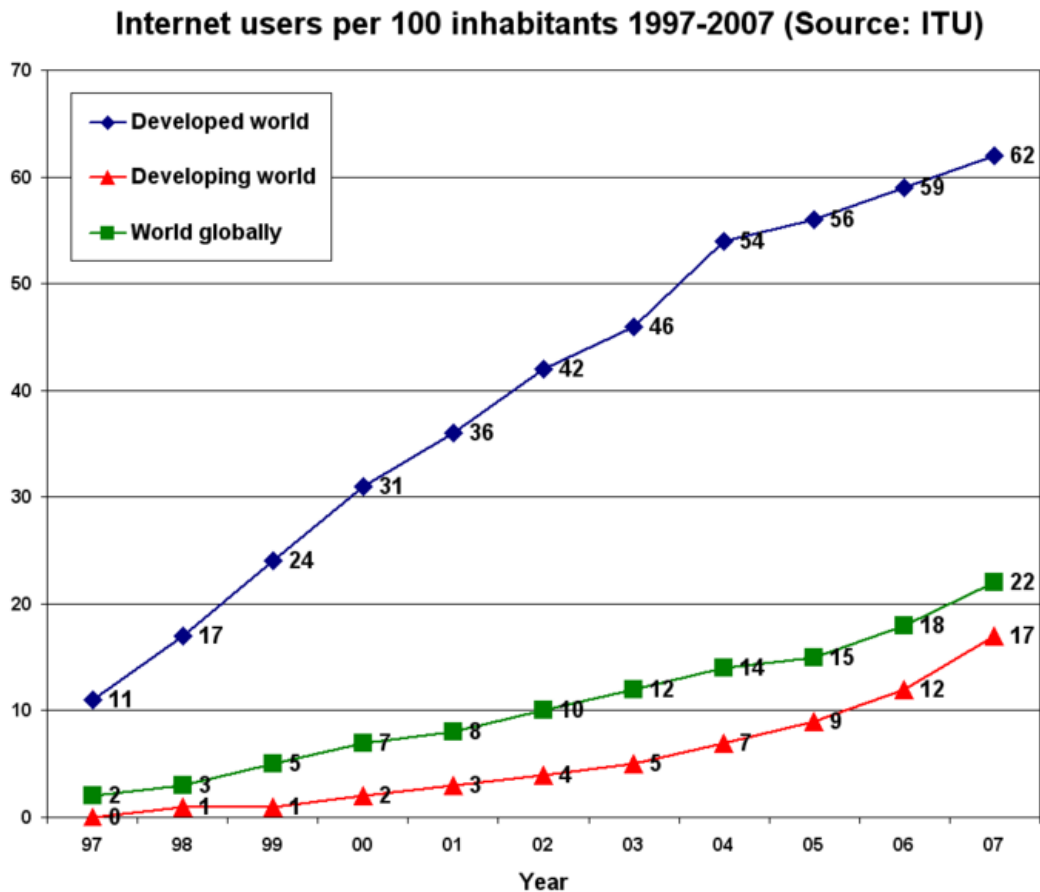

Figure 27: Graph of Internet users per 100 inhabitants between 1997 and 2007 by ITU

8.3 IP and Optical Communications

Along with the emergence of IP as a main network layer resource, there have been a lot of technological advancements in optics as a transmission medium. The view of optical layer as only the transmission medium is changing because of the huge difference of bandwidth between traditional copper cables and fiber optics plus the quick and effective reconfiguration potential of optical layer cross connects (OLXCs). Use of optical networks can provide opportunities to those applications that require huge bandwidth. It can also increase the number of services that a network may host, but at the same time the high speed reconfiguration and an enhanced number of optical channels can complicate the organization of resources (optical). Simple optical networks that are currently in operation use protocols and algorithms that are not resilient enough to incorporate IP. These need to be changed in order to enable it to keep up with the connectivity and capacity that is changing dynamically between network nodes. They should be robust enough to cope with the unavoidable network fluctuations that current day Internet can stand.

The challenge today is to design a network that has no bandwidth bottlenecks, that is responsive to catering to rapid reconfigurations, that is robust to survive network fluctuations yet that is simple enough to reduce any unnecessary and redundant overheads. Thus the challenge is to combine the strength of traditional IP with optical communications. Along with these strengths, the cost factor has to be kept in mind. Network management complexity is one major barrier for a network's responsiveness and cost.

Network management overhead can be attributed to the layered network protocols. Present day IP networks can have typically three or four layers (the number can vary depending on the type and vastness of services offered). For example; an IP packet can be carried in a frame using frame relay which is then encapsulated into an ATM cell. These ATM cells can be embedded into SONET frames [Figure 28(a)]. Each layer in such cases is largely self aware and fully autonomous, completing functions for its own layer and providing services to the layer above it. This increased number of layers reduces the bandwidth efficiency and increases network latency. Since the layers are mostly self aware, there is a lot of duplication of tasks performed by each, like resource management, topology discovery and failure recovery which at times even results in conflicting network management by acting against other layers, therefore, further degrading performance.

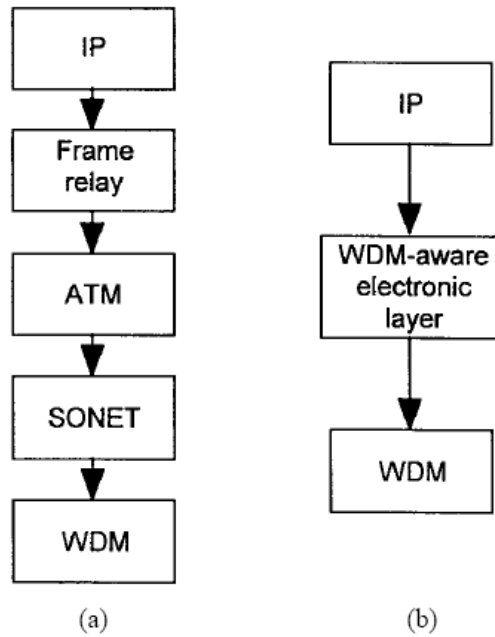

Figure 28: (a) Typical protocol stack and (b) simplified protocol stack³¹

A very effective solution to reducing this overhead and thus complexity of the network is by reducing the number of layers. With increasing capabilities of optical layer, it is highly inviting to have IP simply implemented over WDM [Figure 28 (b)]. This can be done by employing an intermediate WDM-aware electronic layer which will not only reduce the overhead, but being WDM-aware, this layer can also take advantage of the various services that optical layer has to offer. One thing that has to be kept in mind when designing WDM-aware electronic layer is that there are numerous functions that were being taken care of by the intermediate layers like fast restoration and multiplexing (SONET/SDH), traffic engineering (ATM). These along with other are important functionalities must be present in the new optical network. WDM-aware electronic layer can be implemented in various ways.

³¹ Vincent W. S. Chan, Katherine L. Hall, Eytan Modiano and Kristin A. Rauschenbach, "Architectures and Technologies for High-Speed Optical Data Networks" *Journal of Lightwave Technology*, vol. 16, no. 12, December 1998

It can be made part of the above lying IP layer or it can be embedded into the WDM transport network. Whatever the approach maybe, the best practice is to limit each functionality solely as a responsibility of only one layer.

8.4 Conclusion

In this section we discussed the ever increasing demands of Internet and its dependency on IP. We presented the bandwidth inefficiencies of current copper cable network, and proposed to implement IP over AONs. We later discussed the advantages of this approach as well as the challenges being faced. But with growing bandwidth and high-speed network requirements, these challenges will one day be met because when there is a will, there is a way and the will to have practically unlimited bandwidth will one day find its way.

9. Overall Network Architecture of AONs

9.1 Introduction

In this chapter overall network architecture of WDM optical networks is explained. The relationship of optical network layers with OSI reference model is highlighted. Then a generic AON service model architecture is presented to understand the functionality and communication of various layers.

9.2 Optical Layer in OSI reference model

To understand the functionality of optical WDM network while working with IP or other similar protocols, the functionality of the network is broken down into various network layers. The architecture of AONs can be understood by imagining an additional ‘optical layer’ between physical and data link layers. The physical medium in AONs remains optical and an end-to-end path is called a light path. The generalized architecture for WDM AON is important to allow interoperability of various network equipment and smooth transition of network from electronic to optical domain. It is expected that during the migration of Internet to WDM all optical network, heterogeneous network components will exist and hybrid electro-optical network will operate for a long transition time.

It is interesting to note that a lot of active research is going on to deploy WDM networks on large scale networks but little has been done to address the architecture of AONs in general.

ITU-T G.872 is about architectural layers of all optical WDM networks [11] [12].

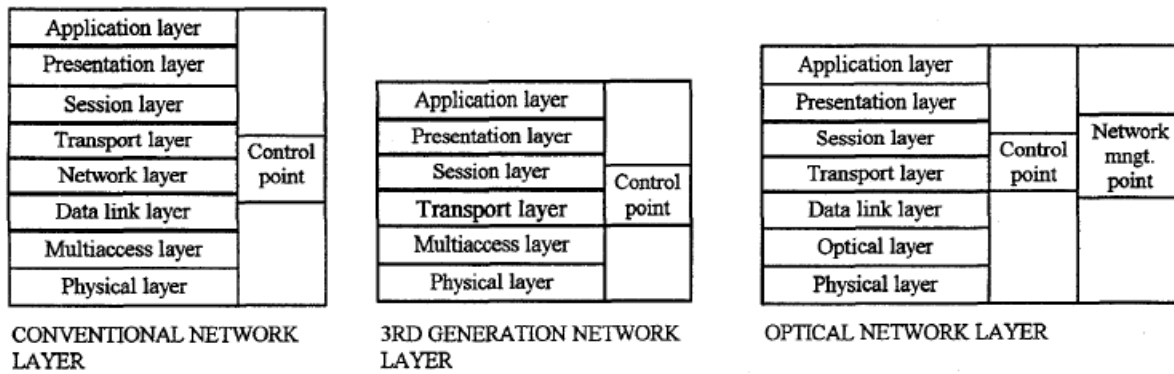

Figure 29: Evolution of Optical Layer in OSI reference model³²

With the presence of all-optical networks it is important to realize that upper layers will still be functioning in electronic domain due to presence of electronic devices. Due to very high bandwidth the existing applications and presentation layers might not be able to cope with AONs and changes will be needed to meet the high-speed network demands. In OSI reference model, some of the network functions were duplicated in more than one layer, e.g., error and flow control was implemented at both data link and transport layer. It is targeted that once all optical network is deployed this complexity can be avoided and clear distinction of responsibilities be made for each layer. Optical network architecture aims to simplify the structure thus making it efficient enough to utilize the bandwidth of optical network efficiently. AONs with circuit switched networks bring a higher degree of transparency. Three generations of network architecture are shown in (Figure 29) [11], [12] and [13].

Green suggested [11] the removal of data link and network layers from 7 layer model. The new optical network model has an ‘optical layer’ inserted between data link and physical

32 Debashis Saha, Debabrata Sengupta “SOME STUDIES ON THE ARCHITECTURAL ASPECTS OF NEXT-GENERATION OPTICAL NETWORKS” 1997 IEEE TENCON - Speech and Image Technologies for Computing and Telecommunications

layer. All the optical functions will be the responsibility of optical layer, e.g., wavelength routing, wavelength conversion, maintaining the information and state of light paths.

9.3 Sub-layers of Optical Layer

As with OSI reference model any layer communicates with its peer layer and layer above and below it. In Optical network model optical layer also talks to optical layer through messages called Service data units (SDUs) and to the layers above and below it by using Protocol data units (PDUs).

Optical layer has three sub layers [12]:

Optical channel layer: This layer is responsible for transmitting the data between end nodes transparently on the flight paths.

Optical multiplex section layer: It is responsible for the networking of light paths that have multiple wavelengths in each optical signal.

Optical transmission section layer: It deals with networking of light paths which contain different optical mediums multi and single mode fiber transmissions.

The overall goal of introducing the optical layer is to render the network functionalities, e.g., communicating with upper layers, provide services like transmit data onto light paths and receive data from light paths and send it to data link layer, perform the wavelength routing/conversion functions and maintain QoS and other network management issues.

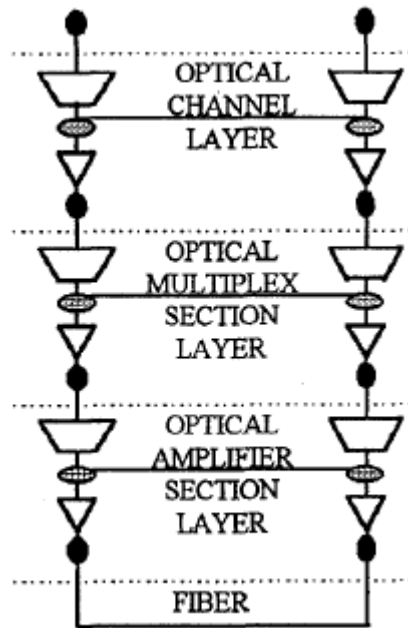

Figure 30: Optical layer -sub layers³³

9.4 Generic Architecture of Optical WDM network

In Figure 31, the broad distribution of optical and electrical layers is shown. It is shown that optical layer can serve various protocols and requests from client layer concurrently. The transparent nature of optical network makes it possible to provide transmission facilities to Sonet, ATM or IP packets at the same time. Light paths are not aware of message types, packet formats and protocols due to transparent nature of AONs. These provide simplicity and at the same time a very high speed and bandwidth.

³³ Debashis Saha, Debabrata Sengupta "SOME STUDIES ON THE ARCHITECTURAL ASPECTS OF NEXT-GENERATION OPTICAL NETWORKS" 1997 IEEE TENCON - Speech and Image Technologies for Computing and Telecommunications

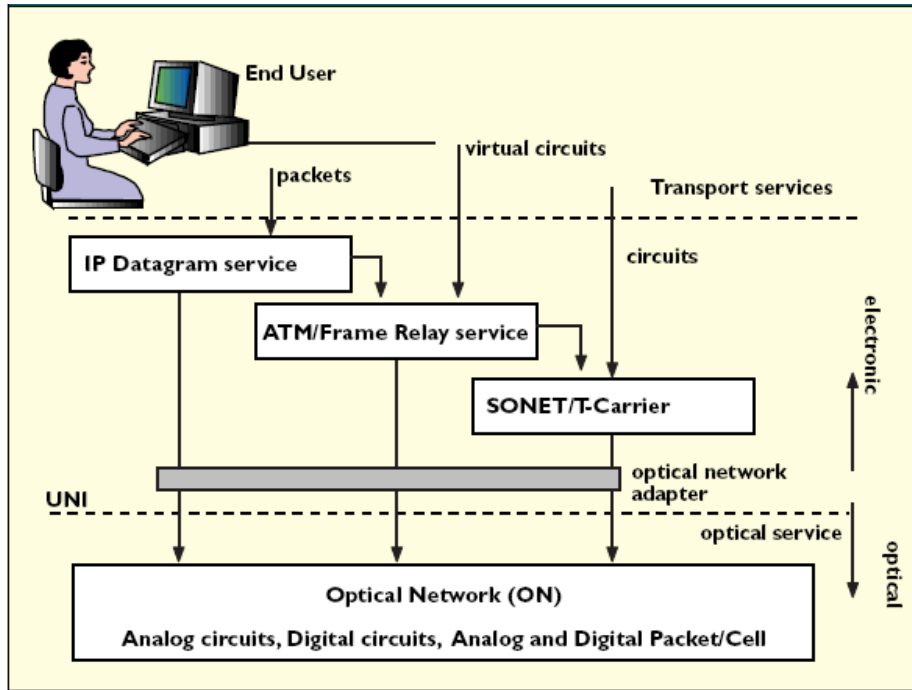

Figure 31: Generic optical WDM network architecture³⁴

Network links (light paths) information is maintained in optical layer. In case of link failure re-routing decisions are also carried out by optical layer, hence the network is reliable.

9.5 Conclusion

In this section standard architecture of all-optical networks is discussed. The introduction of optical layer in a seven layer OSI network model is discussed to show the interaction of various layers with optical layer. Sub layers of Optical layer and their functionalities are also discussed. At the end we gave a generic service model for all-optical network architecture to show how IP layers interact with client layers.

³⁴ A Book "WDM Optical Networks: Concepts, Design, and Algorithms" By Mohan Gurusamy and C. Siva Ram Murthy May 24, 2002

10.All-Optical Network: Project Flamingo

10.1 Introduction

When learning about AONs in general it becomes interesting to know about live test beds of all optical networking technology. A number of research organizations are working in United States, Japan and Europe (list included in Appendix-A). One such project initiated by Dutch Telecom in Netherlands also funded by ICCT (Centre for Telemetric and Information Technology) is Flamingo-Flexible multi-wavelength optical local access network supporting multimedia broadband services. In this chapter an overview to this project will be presented.

10.2 Flamingo's scope

The project was interesting for me because its scope closely matched the topic of my thesis.

The project group is working on different aspects of AONs, e.g., [15] [17].

Technology for optical components - The devices for AONs still need research for making them commercially available. Most important of these components are wavelength converters, optical switches and optical amplifiers.

Technology for transport layer - Various physical topologies are discovered to match with the requirements of WDM networks and higher layer protocols and applications.

Technology for networking layers - The most interesting part of this project was covering the aspects of this area. In order to exploit abundant bandwidth of optical networks higher

layer protocols need to be modified. Flamingo is working on layer 3 protocols to make them suitable for optical WDM networks.

10.3 Flamingo's all-optical network

The architecture of this metropolitan network is based on the concept of rings in each city. These rings make slotted rings architecture [15] [17] and [18]. The WDM rings are bi-directional. The rings are broken down in imaginary slots and access points are shown in figure 32 which access different parts of the ring. Intelligent bridges are used for various routing purposes which make use of buffers in electronic domain.

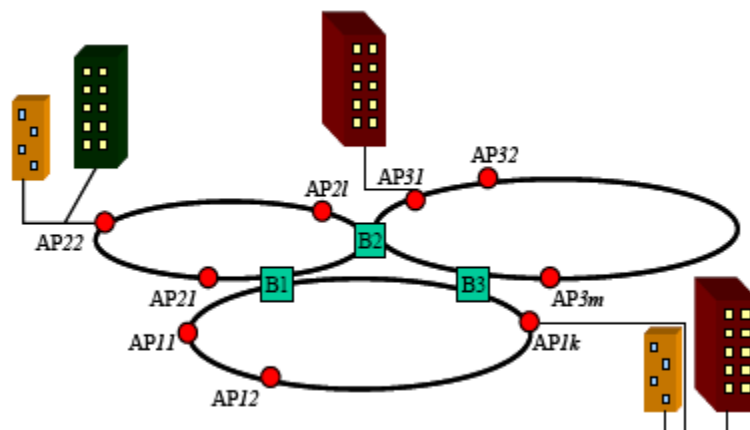

Figure 32: *Interconnected City rings, AP-access points, B-intelligent bridges*³⁵

In this figure, a MAN architecture is connected to heterogeneous networks WAN and LANs through Access points. The slotted ring concept is extended from TDM based network in which multi-channel WDM rings are divided into time slots. Among multiple channels along

³⁵ Marcos Rogério Salvador¹, Sonia Heemstra de Groot, Ignas Niemegeers “**Protocol and networking design issues for local access WDM networks**” Communication Protocols (COM) Group / Telematics Systems and Services (TSS) Centre for Telematics and Information Technology (CTIT) / University of Twente P.O. Box 217 - 7500 AE Enschede, the Netherlands *February, 1999*

circular paths one WDM channel is dedicated for signaling and control information, e.g., headers and other channels might be used for payload of data packets. APs can send data on one wavelength and receive on another wavelength. The channels for headers and payloads are synchronized in such a way that header reaches a bit earlier than the payload. The signaling information on the channels informs the AP if payload for a particular header is on its way on a particular wavelength on the WDM ring. This allows for faster processing of data. Similarly the control information in channel also informs AP about empty slots to put payload on it. This type of architecture offers a high throughput [18] and transports IP packets over all-optical WDM network. This also joins multiple heterogeneous networks through APs and bridges [15] [17] and [18] which is a needed feature for network migrations to AONs

10.4 Conclusion

Dutch Technology Foundation's project Flamingo is an extensive project. A general overview to this project is presented in this section. Additional information about this project can be found in [15] [17] and [18]. This project has addressed the scalability issues of AONs. It also sets out a plan for migration to all-optical networks through introducing devices that will join heterogeneous networks for Internet transition period. The scope of this project is very wide so the discussion is only limited to its unique network design which is considered relevant to the topic of this thesis. Good sources to study its architecture are [38] [39] and [40].

11. Routing in All-Optical networks

11.1 Introduction

This chapter presents an overview of routing in optical networks especially highlighting routing at networking layer in case of large and scalable networks. Routing protocols RIPS, IS-IS and OSPF with reference to optical networks are discussed here.

11.2 Routing in optical networks

Optical networks carry optical cross connects as switching devices. Routing in optical networks means delivering the optical signal to the right port in the cross connect. When an optical network is providing service to upper IP layers, IP network uses IGPs for learning topology of network and (EGPs) finding reachability information to other networks. Similar approach will be required in optical networks when switching and routing is all carried out in optical domain. It is interesting to note that various existing protocols for IP world like RIP, OSPF and IS-IS are explored to work in optical networks. Exactly where these protocols can be used in Optical IP based networks depends upon the overall network architecture. Architecture of optical networks is discussed in chapter 9.

11.3 Routing Information Protocol (RIP)

RIP is a distance vector routing protocol, i.e., it maintains information about network nodes and its distance from each node. RIP is an extension of Belmenford algorithm [20], especially developed for dynamic environment. When this protocol is allowed to work in optical

domain the networking nodes like optical switches or optical cross connects will take the place of routers. The limitations of this routing protocol like network size, slow convergence, and count to infinity can occur in optical domain as well. Therefore the study suggests that RIP is not a very successful routing protocol in large optical networks, e.g., MANs.

11.4 Intermediate systems-intermediate systems (IS-IS)

IS-IS is a link state routing protocol which means that it maintains the information of links. This way a link state algorithm maintains topology information at each node. In case of optical networks, the links state information '*light paths*' will be saved [19] [20] [21]. IS-IS has many desirable features like supporting scalability and QoS but it is not an Internet Engineering Task Force (IETF) standard. IS-IS can work in an environment where multiple protocols are running therefore it can be an ideal for optical networks at its heterogeneous stage. The only risk involved in extension of this protocol for WDM optical networks would be that it is no longer an open standard.

11.5 Open shortest path first (OSPF)

Open shortest path first (OSPF) overcomes the problems of RIP and IS-IS as it is scalable to large networks. It is also a defined IETF standard. OSPF is considered a simple and generic networking protocol that can work in heterogeneous networks. An extension of OSPF is already developed for optical networks. RFC3717 is a document that explains implementation of OSPF in optical network domain [20] [21]. OSPF is a successful routing

protocol in networking and its extension to optical domain seems promising as it incorporates sophisticated traffic engineering and QoS features that will be required at application layer of modern IP based networks of future.

11.6 Conclusion

An overview of routing in optical domain is presented with emphasis on third layer routing protocols in IP environment. Possible extension of networking protocols like RIP, IS-IS and OSPF in optical domain is also discussed. OSPF seems to be a promising layer 3 protocol that can work with optical networks as discussed in its RFC 3717.

12.Challenges faced in deploying AONs

12.1 Introduction

In this chapter, we discuss few of the most important challenges faced in deployment of all optical WDM networks. Widely deployed WDM networks today are not completely optical, i.e., the connection between two nodes is optical as long as it's a direct connect not involving any switching or routing. But for wider networks, there are lots of elements in the network that require electro-optical conversions which affect the overall network performance and bandwidth. The race has already started for migrating today's '*semi-optical networks*' to all-optical networks. But the ultimate goal to reach a network where, except for the physical end nodes, there are no electrical components and there are no intermediate conversions, where the vast bandwidth of optical fibers and the high speed of light are fully utilized, is not easily

attainable. There are several major challenges that must be overcome in order to realize this dream. There are issues like network design and topologies, wavelength assignment, supporting multivendor environments and control.

12.2 Routing and Wavelength Assignment

Routing and Wavelength Assignment (RWA) [10] [19] [53] algorithm is used to select the nodes, wavelengths between those nodes and best routes in the network. Since a WDM network is totally based on '*light paths*' between nodes, to establish the connection, wavelengths have to be assigned continuously. Therefore, it is very important to use the correct form of RWA algorithm.

12.2.1 Static Vs Dynamic Traffic Demand

Wavelength allocation in a WDM network can be static or dynamic. Each mode has its own pros and cons, and each has its own hurdles. With static demand, the connections between different nodes are all pre-determined. These connections are based on the long term usage of the links between those nodes. The goal is to satisfy all demands with the assignment of routes and wavelengths, so as to fulfill maximum demands using minimum number of wavelengths. This problem is known as '*static light path establishment (SLE)*' problem [10]. So far, the SLE problem is categorized as NP-Complete [10][19]; this is the class of problems that have no known algorithm that gives the right solution, therefore, the only solution that are currently available are the ones that will produce results close to but not exactly optimal.

With dynamic demand, the routes and wavelengths are assigned as required. Whenever a demand is received for a connection between two nodes, a new or previously used wavelength (which requires disconnection of the previous nodes) is assigned based on the type of request. This wavelength is assigned for a finite time and can be discontinued once it is required to fulfill other demands. New demands can be for a new connection between nodes as well as a re-route due to network failure and congestion of links or nodes. In dynamic RWA, unlike static, the requests have to be entertained online so the solution required should be simple (computationally) as well as fast and dynamic. The goal here is to maximize the number of demands satisfied.

Static RWA is more efficient in wavelength assignments than dynamic, as the connections requests in dynamic algorithm are never known and it can never look into the future demands so it will only satisfy the demands as needed. In static mode, however, all the routes are pre-calculated and wavelengths assigned. These assignments in static RWA are on the basis of some heuristics, one of which can be to assign wavelengths first to those requests that have a higher number of hops as they are more likely not to find the same wavelength through their journey [10][53]. For AONs, the challenge is to modify RWA algorithm in such a way that it will be able to produce results for the static traffic demands in real time.

12.2.2 Centralized Vs Distributed Control

In centralized RWA control, one of the nodes is assigned as a controller that has the correct information about the state of complete network whereas in distributed control, no node

controls the network. Moreover, in this mode, none of the nodes has the latest info about the network. Whenever a new light path connection needs to be assigned, in centralized RWA, the controller assigns routes and wavelengths (it might use static or dynamic traffic demand) and in case of disconnection, it is again the controller which sends the control messages for releasing the light path. With distributed approach, whenever a node receives this request for a new connection, it may perform the breadth first search to assign routes and wavelengths. It will send control messages to other neighboring nodes for wavelength reservations. Once confirmation is received, it will send switching information. Similarly, for disconnects, the node sends out release signals to neighboring nodes to free the wavelength and route.

Centralized control is ideal for smaller networks, but a single node cannot maintain the complete network information for bigger networks. For wider networks, distributed RWA control is a better choice.

The greater challenge in RWA control is the *fairness* problem [10] [53]. When two simultaneous requests are received for new light path, the one requiring fewer hops is likely to be satisfied first because there is more chance for the greater hops request that the same wavelength will not be found. This problem is still limited in smaller networks using centralized control but as the network grows, the problem is worsened with distributed RWA control. Since the ultimate aim of optical networks is to have optical WDM Internet (or *optical Internet*) this has become a major challenge for designers of AONs. This approach is needed that will not compromise network performance, but improve the fairness issue in

control of WDM network. One resolution proposed for this issue is to use wavelength convertible networks explained below. Such equipment is not commercially available and is still in its infancy, plus it will further increase the network cost.

12.2.3 Wavelength Convertible Networks

One of the possible solutions to overcome above issue is by using wavelength converters that enable the use of one wavelength in one hop and if the same wavelength is not available in the next hop for the same data signal, the information can be transferred to another wavelength and then sent forward. Such a network is called *wavelength convertible network*. A node having a wavelength converter is a wavelength converting node and the number of wavelength it can convert is the degree of its conversion. A node with full degree of conversion [10] [53] is the one that has a conversion degree of all the wavelengths times fibers connected.

The maximum number of converters a node can have is

$$F_{in} \times W$$

Equation 5: *Max wavelengths converters for a node in WDM network.*³⁶

Where, F_{in} is the number of fiber links on the node and W is the number of wavelengths per fiber.

When all the nodes in the network that require full degree conversion achieve it, the network becomes best achievable network in terms of performance but that is not economically

³⁶ A Book “WDM Optical Networks: Concepts, Design, and Algorithms” By Mohan Gurusamy and C. Siva Ram Murthy May 24, 2002

feasible because of the expensive converters which are not readily available commercially. Therefore, to keep the network cost efficient, only a certain number of nodes can have the wavelength converters but the challenge is how many nodes can have this luxury, what are the number of converters a node can have is and what are the criteria of choosing or discarding a node to have converters. It is proven that a wavelength convertible network has a better performance [10] [19] than *wavelength selective network* (the one without any wavelength conversion) but the above challenges need to be overcome in order to fully utilize the vast optical bandwidth.

12.3 Lack of Switching/Routing Equipment

Optical fibers have been in place for quite some time but only in the access network. The core has so far not been a part of this new innovation. The switches and routers are still electric which means a lot of electro-optical conversions for a message during its transmission between two nodes. There are optical switches that are in research stages but no switching exists that is *perfectly* optical. With so much work done on electrical switches and routers, they have much more flexibility and control, but the same seems very far away in optical domain. With the signals being all optical, optical switches will need to be fast enough to switch them efficiently without loss of data. This is a very big challenge in realization of AONs today.

12.4 High CAPEX for AONs

Since the optical networks are still in their infancy, the optical equipment available today is very expensive. Replacing the existing networks with AONs means replacing the old electrical equipment with new optical equipment which will be a big step for the industry. High cost issue needs to be overcome to encourage the big companies to invest in AONs. For example, the optical amplifiers are required throughout the optical network at regular distances but they are very cost inefficient which make the overall cost of the network go very high when the network expands [14]. Since the legacy networks have been in place for so long, the equipment is far more available and inexpensive as compared to optical equipment. Plus with so many years of advancements in electrical domain, electrical switch, routers and microprocessors are far more superior in functionality than their counterparts in optical domain. This is a big challenge because the big market players are looking for the same superiority and flexibility in optical equipment as they currently have in electrical ones.

12.5 Lack of Network Intelligent Tools

A network can never be successful if it has no network management tools that gather important information from the network, decode the messages intelligently and provide human interpretable data about the performance, faults, and utilization of the network. An optical network consists of high-speed fiber links which carry light signals. The network management tools currently being used for electrical networks cannot be used for the optical

domain as the speed of the data in both is incomparable. A system of intelligent tools is required that is fast enough to capture the signals travelling on every fiber link and process the information to produce readable results. Moreover, the migrating from legacy to optical network can never be a one night process. It will involve transition periods when both electrical and optical networks will co-exist, and operators will not want to have two separate management tools. So the need is to have a hybrid network management system that enables the operator to migrate smoothly from electrical to optical, giving it the power over faults and allowing it to take immediate steps to overcome those faults [14] and [41].

12.6 Lack of Trained Professionals

Finally, there are not enough individuals trained to work on the AONs. It takes time to train professionals on the new technology and bring them up to speed. For the development of new equipment, new tools, deployment of AONs and finally managing them, all of this requires trained personnel.

12.7 Conclusion

In this section we have reviewed the problems faced by AONs in commercial deployment. These challenges are being addressed by research groups working on AONs in US, Japan and European parts of the world. Some possible solutions to these challenges are also discussed hence it is realized that AONs commercial deployment may seem difficult but it is not impossible!

13. Optical Transport Planner Simulations

13.1 Introduction

SP Guru® Transport Planner is a powerful tool that allows network planning and optimization in simulated environment. This SP Guru tool is especially designed for optical networks. Network designers can model various networks and use advanced optical components in opaque, transparent and test networks over a number of traffic and fault conditions. It also allows comparing costs of various network models. More details about this software could be found at [66]. In this section we will explore some interesting facts about WDM networks through this tool and draw conclusions.

13.2 Designing a Network based on Flamingo Model

In figure 33, a network topology is created based on Flamingo model discussed in section 10. There are three cities namely City A, B and C. Each city contains a multi-channel WDM ring. Three rings are further joined by another multi-channel WDM ring to provide a bi-directional link between cities which also makes the network resilient. This diagram shows the basic topology. We have used OCC (optical cross connects) in this diagram but we will also use EOCC (electro-optical cross connects) for various comparisons. Appendix B contains figures for setting up the network in transport planner.

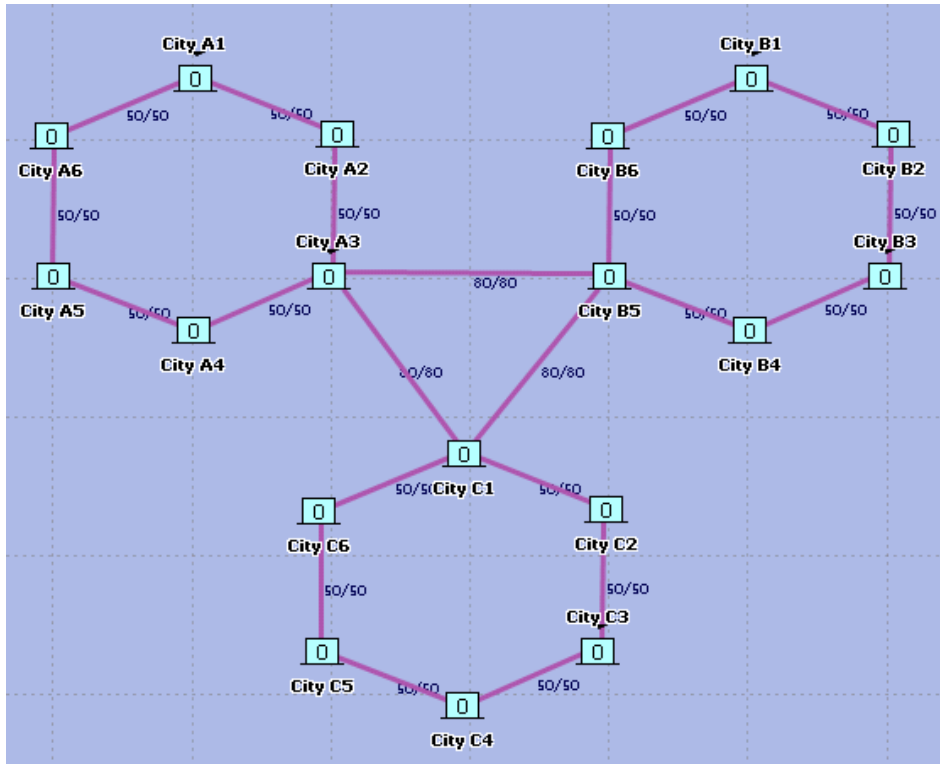

Figure 33: *Opnet Transport Planner Flamingo based network model*

13.3 Performance Comparison: OOO Vs OEO Networks

We have configured two types of networks in transport planner, both based on the Flamingo topology. The first one as shown earlier in figure 33 is an all-optical network (or OOO network) with completely optical elements. The signals in this network remain optical throughout their transmission. The second network is shown below in Figure 34 which has electro-optical cross connects. As before, the transmission links are still optical fibers, but the switching is done in electrical domain, so this network involves conversions from optical to electrical and back to optical domain.

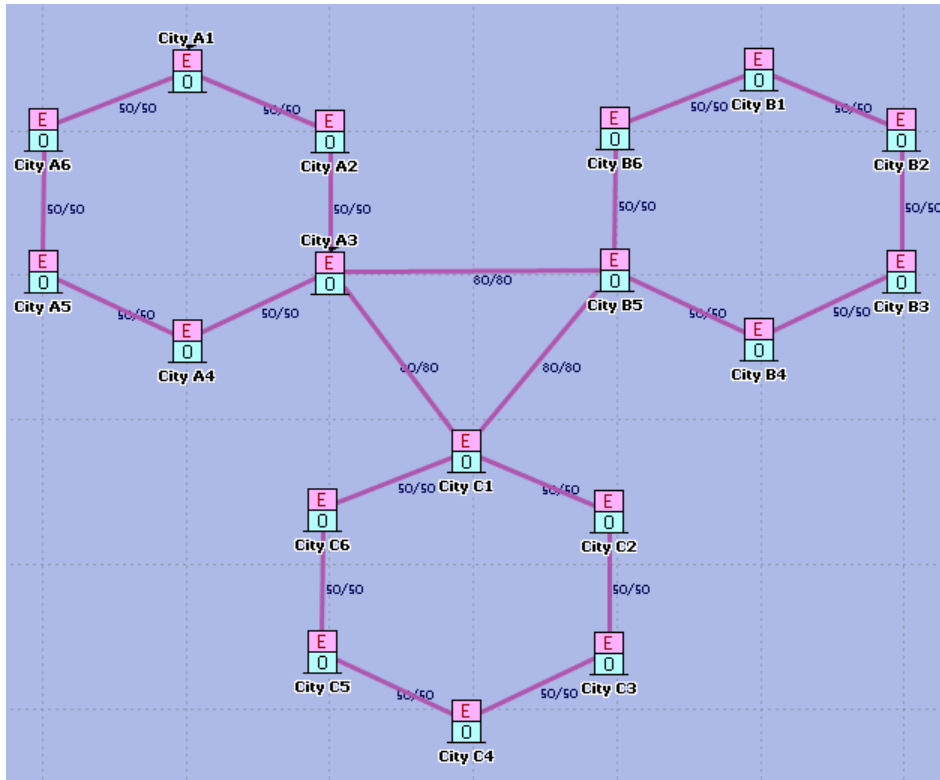

Figure 34: *Flamingo based Electro-Optical Network*

Both networks are designed with identical network properties. Transport planner has a feature to transmit traffic on each link as desired. The available values are 0 and greater. These are arbitrary values and are only used for comparison purposes. For example, for a particular link, if we choose traffic 4, that means this link is carrying traffic more than the ones having traffic 3 or less and is less than the ones having traffic 5 or greater.

For comparing the performance of OOO and OEO networks, we first presented each network with a traffic matrix having values randomly chosen between 1 and 15. Figure 35 and Figure 36 are the summarized web reports generated by transport planner for OOO and OEO networks respectively. Important points to note in these reports are the percent traffic routed and node and link utilization. As can be seen in below reports, both networks have routed

100% traffic with almost same link utilization (threshold set for link utilization is 80% after which next fiber pair is utilized from the unused bunch). The only thing worth noticing is that the node utilization in OOO network is much less as compared to OEO (which suffers from electro-optical conversion bottlenecks).

Overview						
Used Traffic Matrices						
Traffic Matrix	Newly Routed Connections	Total Routed Connections	Demanded Connections	Percent Routed	Total Hops of Working Paths	Mean Hops of Working Paths
OCH_Random (1_15)	1,165	1,165	1,165	100.0	3,715	3.189

Utilization	
Variable	Value
OCH Used Link Capacity	3,715 wavelengths
OCH Equipped Link Capacity	5,160 wavelengths
OCH Link Utilization	72.0%
OCH Node Utilization	13.24%

Figure 35: OOO Network Performance with Random Traffic Matrix (1-15)

Overview						
Used Traffic Matrices						
Traffic Matrix	Newly Routed Connections	Total Routed Connections	Demanded Connections	Percent Routed	Total Hops of Working Paths	Mean Hops of Working Paths
OCH_Random(1-15)	1,185	1,185	1,185	100.0	3,850	3.249

Utilization	
Variable	Value
OCH Used Link Capacity	3,850 wavelengths
OCH Equipped Link Capacity	5,240 wavelengths
OCH Link Utilization	73.47%
OCH Node Utilization	21.66%

Figure 36: OEO Network Performance with Random Traffic Matrix (1-15)

To have a precise comparison, next each network is presented with uniform traffic matrix (each link in each network carrying the same amount of traffic). Both networks are tested

with uniform traffic matrices of 5, 10, 20, 50 and 100 and Table 1 below summarizes the results. The web reports for tests are available in Appendix B.

	OOO			OEO		
Traffic Matrix	Node Util.	Link Util.	% Routed	Node Util.	Link Util.	% Routed
Random (0 – 15)	13.24	72.0	100	21.66	73.47	100
Uniform (5)	9.03	71.25	100	20.65	71.25	100
Uniform (10)	18.07	75.0	100	40.76	78.22	100
Uniform (20)	36.13	77.73	100	66.4	75.17	92.55
Uniform (50)	74.27	79.27	94.12	97.56	67.98	35.59
Uniform (100)	79.91	79.37	61.44	98.0	74.87	17.85

Table 1: Performance Comparison between OOO and OEO Networks

The graph in figure 37 shows the comparison of node utilization in all optical and electro-optical networks. It is shown that as the traffic on the network increases, node utilization also increases. In case of electronic nodes which involve electro-optical conversions, node utilization is always higher. It reaches critical zone of 90% and above for a traffic matrix of 50.

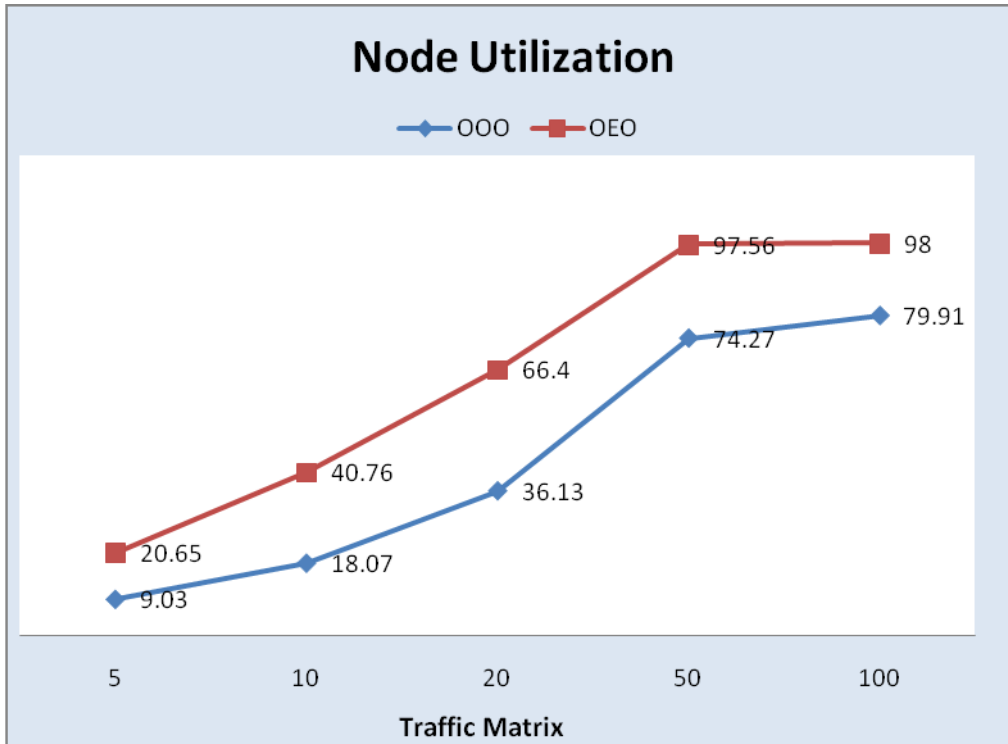

Figure 37: Graph of OOO vs. OEO network (node utilization)

The following graph shows link utilization in OOO and OEO networks. All-optical network performs very well with increase in traffic matrix.

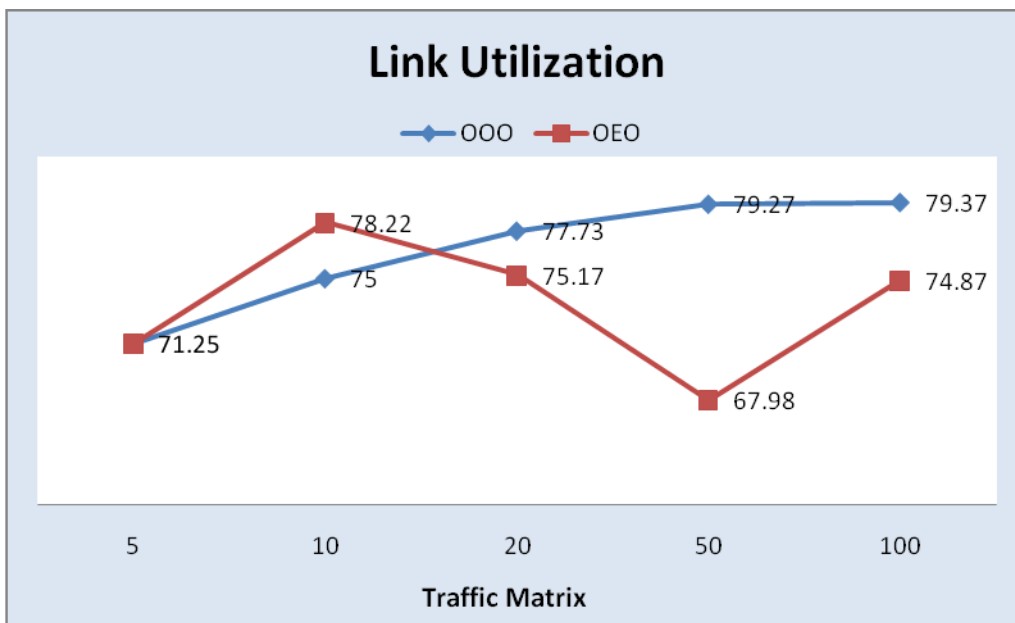

Figure 38: Graph of OOO vs. OEO network (Link Utilization)

The graph shown in figure 39 shows the comparison between the percentage of traffic routed in both the OOO and OEO networks. With the increase in traffic over the network, all-optical network keeps the percentage of routed traffic in higher levels as compared to EOE network.

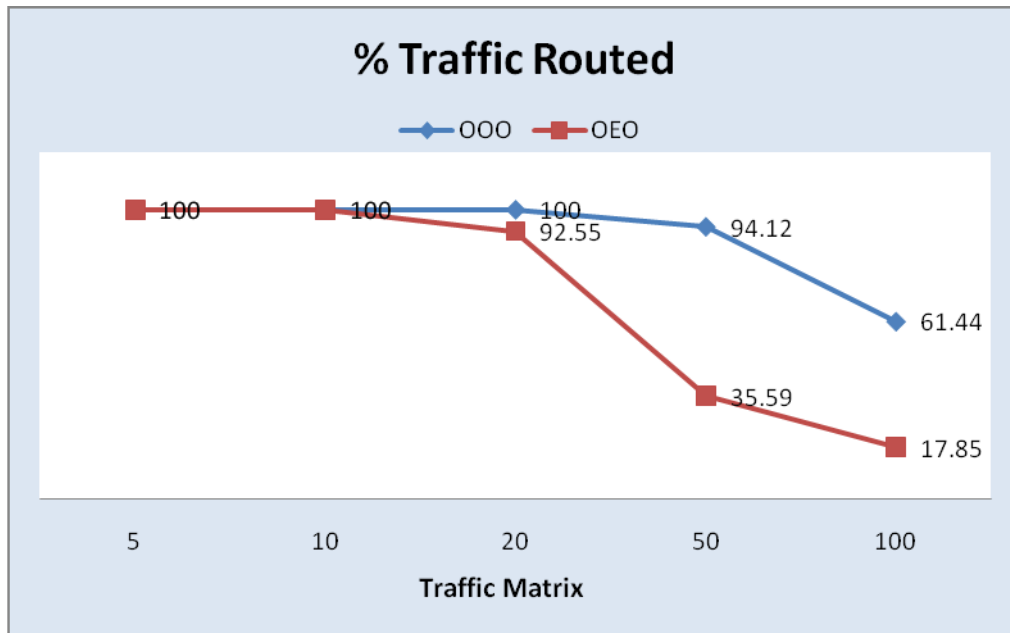

Figure 39: Graph of OOO vs. OEO network (% traffic routed)

13.4 Impact of Increasing Number of WDM wavelengths

In all above tests, we used the default number of WDM wavelengths, i.e., 40 per fiber. We now test both networks with doubled number of wavelengths, i.e., 80 per fiber and compare the performance. Both networks will be tested with uniform traffic matrix of 100.

Overview

Used Traffic Matrices

Traffic Matrix	Newly Routed Connections	Total Routed Connections	Demanded Connections	Percent Routed	Total Hops of Working Paths	Mean Hops of Working Paths
OCH_0	14,400	14,400	15,300	94.12	47,500	3.299

Utilization

Variable	Value
OCH Used Link Capacity	47,500 wavelengths
OCH Equipped Link Capacity	59,920 wavelengths
OCH Link Utilization	79.27%
OCH Node Utilization	98.81%

Figure 40: OOO Network Performance with doubled WDM Wavelengths

Overview

Used Traffic Matrices

Traffic Matrix	Newly Routed Connections	Total Routed Connections	Demanded Connections	Percent Routed	Total Hops of Working Paths	Mean Hops of Working Paths
Unifrom100	9,862	9,862	15,300	64.46	26,098	2.646

Utilization

Variable	Value
OCH Used Link Capacity	47,903 wavelengths
OCH Equipped Link Capacity	70,480 wavelengths
OCH Link Utilization	67.97%
OCH Node Utilization	98.75%

Figure 41: OEO Network Performance with doubled WDM Wavelengths

The results shown in Figure 40 and Figure 41 clearly show that doubling the number of wavelengths improves the percentage of traffic routed. This improvement in OOO network takes it to route almost 95% again. However, there is a limit to increasing the number of wavelengths as the equipment becomes very sensitive and thus expensive and difficult to design.

13.5 Conclusion

In this section we designed Flamingo based OOO and OEO networks using Opnet transport planner. We provided a comparison between these two networks using different traffic matrices. It was shown in each case that OOO network performs better than OEO as it doesn't suffer the electro-optical conversion bottlenecks. .

14. Conclusion

This thesis has explored various aspects of all-optical networks and proved that all-optical networks perform better than electro-optical networks in a number of ways. The performance is compared in Opnet Transport Planner Simulations with varying traffic matrices and it is proved that node utilization, link usage and percentage traffic routed in case of all-optical networks remain better.

Telecommunications networks are constantly evolving in order to meet bandwidth demands of booming telecom industry. The migration from legacy to optical network can never be a one night process. It will involve transition periods when both electrical and optical networks will co-exist. A high bandwidth is an explicit dream but it is still a dilemma whether transparency is the ultimate goal for network evolution. At times transparency is good and at times it is not. It is observed that for packet based networks transparency is not ideal as in normal mode of IP, the router reads and forwards a packet. In order to achieve the same

flexibility of IP optical Internet should not be purely transparent. While for circuit switched networks transparency is perfect!

Internet was one revolution that emerged about ten years ago. It is very hard to predict anything for telecom networks during next ten years but optical communication will surely make its place in changing face of telecom infrastructure.

It is realized that packet switching took over typical circuit switching in the past both in its benefits to the scalability and network costs to operators. History will repeat itself for optical networks and one day networks will again start using opaque optical devices for high level functions like routing and setting up policies and QoS in all-optical domain.

15. References

- [1] Sci-Tech encyclopedia at <http://www.answers.com/topic/optic>
- [2] Samir Chatterjee and Suzanne Pawlowski “Enlightening the Effects and Implications of Nearly Infinite Bandwidth,” Communications of the ACM, June 1999 Vol. 42, No. 6 [Online] <http://portal.acm.org/citation.cfm?id=303865>
- [3] National Communications System – Technical Information Bulletin 00-7 “All-Optical Networks (AON),” [Online] http://www.ncs.gov/library/tech_bulletins/2000/tib_00-7.pdf
- [4] S.B. Alexander, R.S. Bondurant, D. Byrne, V.W.S. Chan, S.G. Finn, R. Gallager, B.S. Glance, H.A. Haus, P. Humblet, R. Jain, I.P. Kaminov, M. Karol, R.S. Kennedy, A. Kirby, H.Q. Le, A.A.M. Saleh, B.A. Scho_eld, J.H. Shapiro, N.K. Shankaranayanan, R.E. Thomas, R.C. Williamson, R.W. Wilson, “A Precompetitive Consortium on Wide-Band All-Optical Networks,” IEEE Journal of Lightwave Technology, Vol. 11 No. 5/6, pp. 714-735, May/June 1993.
- [5] I.P. Kaminov, C.R. Doerr, T. Koch, U. Koren, A.A.M. Saleh, A.J. Kirby, C.M. Ozveren, B. Scho_eld, R.E. Thomas, R.A. Barry, D.M. Castagnozzi, V.W.S. Chan, B.R. Hemenway, D. Marquis, S.A. Parikh, M.L. Stevens, E.A. Swanson, S.G. Finn, R.G. Gallager, “A Wideband All-Optical WDM Network”, IEEE Journal on Selected Areas in Communications, vol. 14, no. 5, pp. 814-823, June 1996.

- [6] Altan Kocycit, Demeter Gokisik, Semih Bilgen "All-Optical Networking", Electrical and Electronics Engineering Department, Middle East Technical University, 06531 Ankara, TURKEY, Turk J Elec Engin, VOL.9, NO.2 2001, C TU`BI_TAK.
- [7] M.S. Borella, J.P. Jue, D. Banerjee, B. Ramamurthy, B. Mukherjee, "Optical Components for WDM Lightwave Networks," Proceedings of the IEEE, vol. 85, no. 8, pp. 1274-1307, August 1997.
- [8] Esa Hyyti, thesis on "Dynamic Control of All-Optical WDM Networks" Supervisor: Professor Jorma Virtamo, Helsinki University of Technology, Department of Electrical and Communication Engineering Networking Laboratory [online] http://www.netlab.tkk.fi/tutkimus/cost257/publ/thesis/thesis_esa_01.pdf
- [9] Marian Marciniak "OPTICAL TRANSPARENCY AND OPTICAL OPACITY IN FUTURE ALL-OPTICAL PACKET SWITCHED NETWORK" National Institute of Telecommunications, Department of Transmission and Fiber Technology, [online] <http://www.ursi.org/Proceedings/ProcGA02/papers/p1719.pdf>
- [10] A Book by Mohan Gurusamy and C. Siva Ram Murthy "WDM Optical Networks: Concepts, Design, and Algorithms", May 24, 2002
- [11] P.E.Green, "The future of Fiber-Optic Computer Networks," IEEE Computer, pp. 78-87, September 1991.
- [12] Debashis Saha, Debabrata Sengupta "SOME STUDIES ON THE ARCHITECTURAL ASPECTS OF NEXT-GENERATION OPTICAL NETWORKS" 1997 IEEE Tencon - Speech and Image Technologies for Computing and Telecommunications.
- [13] B.Mukhejee, D.Banerjee, S.Ramamurthy, and A.Mukherjee, "Some principles for designing a wide area WDM optical network," IEEE/ACM Trans. Networking, vol. 4, no. 5, pp. 684-696, October 1996
- [14] Shoa-Kai Liu "Challenges of All-Optical Network Evolution" IEEE Lasers and Electro-Optics Society Annual Meeting, 1998. LEOS apos;98. IEEE Volume 1, Issue , 1-4 Dec 1998 Page(s):182 - 183 vol.1
- [15] Dey, D. van Bochove, A. Koonen, A. Geuzebroek, D. Salvador, M. Fac. of Electr. Eng., Twente Univ., Enschede, Netherlands "FLAMINGO: a packet-switched IP-over-WDM all-optical MAN" Presented in IEEE Optical Communication, 2001. ECOC '01. 27th European Conference, Volume: 3, On page(s): 480- 481 vol.3
- [16] Jaafar M. H. Elmirghani and Hussein T. Mouftah. "Technologies and architectures for scalable dynamic dense WDM networks," IEEE Commun. Mag., 38(2):58-66, February 2000.
- [17] Marcos Rogério Salvador¹, Sonia Heemstra de Groot, Ignas Niemegeers "Protocol and networking design issues for local access WDM networks" Communication Protocols (COM) Group / Telematics Systems and Services (TSS) Centre for Telematics and Information Technology (CTIT) / University of Twente P.O. Box 217 - 7500 AE Enschede, the Netherlands February, 1999
- [18] D. Dey, A.M.J. Koonen, A.C. van Bochove "Scalability of an All-optical Multiwavelength Slottedring Metropolitan Area Network Proceedings Symposium IEEE/LEOS Benelux Chapter, 2002, Amsterdam 135

- [19] H. Zang, J. Jue, and B. Mukherjee. A Review of Routing and Wavelength Assignment Approaches for Wavelength-Routed Optical WDM Network. *Optical Networks Magazine*, August, 1999
- [20] Ghassen Ben Brahim - Bilal Khan - Abdella Battou - Mohsen Guizani - Ghulam Chaudhry "Routing Protocols for Optical Network" [online] available at: <http://www.cmf.nrl.navy.mil/ccs/project/public/DC/web/projects/tron/pdcs2000/html/paper1.html>
- [21] RFP 3717 - IP over Optical Networks: A Framework [online] available at <http://www.faqs.org/rfcs/rfc3717.html>
- [22] Arjan Durresi¹, Raj Jain², Nikhil Chandhok¹, Ramesh Jagannathan¹, Srinivasan Seetharaman¹, and Kulathumani Vinodkrishnan¹ "IP over all-optical networks – Issues" IEEE Global Telecommunications Conference, 2001. Globecom '01. IEEE Publication Date: 2001 Volume: 4, On page(s): 2144-2149 vol.4 [online] available at http://www.cs.wustl.edu/~jain/papers/ftp/ipo_issues.pdf
- [23] Vincent W. S. Chan, Fellow, IEEE, Katherine L. Hall, Senior Member, IEEE, Member OSA, Eytan Modiano, Member, IEEE, and Kristin A. Rauschenbach, Member, IEEE "Architectures and Technologies for High-Speed Optical Data Networks," *Journal of Lightwave Technology*, Vol 16, No. 12, December 1998.
- [24] B. Mukherjee, "WDM-based local lightwave networks, Part I: Singlehop systems," *IEEE Network*, May 1992.
- [25] All-Optical Networks, <http://cello.asc.cise-nsf.gov/ncri/giga/allopticalnets.paper.txt>
- [26] I.Kaminow, C. Doerr, and et al. "A Wideband All-Optical WDM Network," *IEEE Journal on Selected Areas in Communications*, Vol. 14, No. 5, Jun. 1996
- [27] Mari W. Maeda, "Management and Control of Transparent Optical Networks," *IEEE Journal of Selected Areas in Communications*, Vol. 16, No. 7, Sep. 1998
- [28] Michael J. O'Mahony, Senior Member, IEEE, Christina Politi, Student Member, IEEE, Dimitrios Klondis, Member, IEEE, Reza Nejabati, Member, IEEE, and Dimitra Simeonidou, Member, IEEE "Future Optical Networks" *Journal of Lightwave Technology*, Vol. 24, No. 12, December 2006
- [29] L. Gillner, C. P. Larsen, and M. Gustavson, "Scalability of Optical Multiwavelength Networks: Crosstalk Analysis", *Journal of Lightwave Technology*, vol. 17, no. 1, January 1999, pp. 58-67
- [30] R. A. Barry, V. W. S. Chan, K. L. Hall, E. S. Kintzer, J. D. Moores, K. A. Rauschenbach, E. A. Swanson, L. E. Adams, C. R. Doerr, S. G. Finn, H. A. Haus, E. P. Ippen, W. S. Wong, and M. Haner, "All-optical network consortium-ultrafast TDM networks," *J. Lightwave Technol./IEEE J. Select. Areas Commun.*, vol. 14, no. 5, p. 999, 1996
- [31] D. Banerjee, J. Frank, B. Mukherjee, Passive Optical Network Architecture Based on Waveguide Grating Routers," *IEEE Journal on Selected Areas in Communications*, vol. 16, no. 7, pp. 1040-1050, September 1998.
- [32] M.S. Borella, B. Mukherjee, Efficient Scheduling of Nonuniform Packet Trac in a WDM/TDM Local Lighthwave Network with Arbitrary Transceiver Tuning Latencies," *IEEE Journal on Selected Areas in Communications*, vol. 14, no. 5, pp. 923-934, June 1996.

- [33] B. Ramamurthy, B. Mukherjee, "Wavelength Conversion in WDM Networking," *IEEE Journal on Selected Areas in Communications*, vol. 16, no. 7, pp. 1061-1073, September 1998.
- [34] R. Ramaswami, K.N. Sivarajan, "Design of Logical Topologies for Wavelength-Routed Optical Networks," *IEEE Journal on Selected Areas in Communications*, vol. 14, no. 5, pp. 858-867, June 1996.
- [35] A.R. Modarressi, S. Mohan, "Control and Management in Next-Generation Networks: Challenges and Opportunities," *IEEE Communications Magazine*, pp. 94-102, October 2000.
- [36] T. Li, "MPLS and the Evolving Internet Architecture," *IEEE Communications Magazine*, pp. 38-41, December 1999.
- [37] E. Modiano, R. Barry, and E. Swanson, "A novel architecture and medium access control (MAC) protocol for WDM networks," in *Proc. OFC'98*, San Jose, CA, Feb. 1998.
- [38] D. Dey, A.M.J. Koonen, D. Geuzebroek, M.R. Salvador, "FLAMINGO: A Packet-switched IP over WDM Metro Optical Network", in *Proceedings of Networks and Optical Communications Conference (NOC)*, June 2001, pp 400-406.
- [39] D. Dey, A. van Bochove, A. Koonen, D. Geuzebroek, M. Salvador, "FLAMINGO: A Packet-switched IP-over-WDM All-optical MAN", in *Proceedings of the 27th European Conference on Optical Communications (ECOC)*, September 30 – October 4, 2001, vol. 3, pp 480-481.
- [40] D. Dey, A.M.J. Koonen, M.R. Salvador, "Network Architecture of a Packet-switched WDM LAN/MAN", in *Proceedings of the IEEE/LEOS Symposium, Benelux Chapter*, October 30, 2000, pp 251-254.
- [41] B. Mukherjee, "WDM Optical Communication Networks: Progress and Challenges," *IEEE Journal on Selected Areas in Communications*, vol. 18, no. 10, pp. 1810-1824, October 2000.
- [42] M. Alanyal, E. Ayano, "Provisioning Algorithms for WDM Optical Networks," *IEEE/ACM Transactions on Networking*, vol.7, no. 5, October 1999.
- [43] P. P. Iannone, N. J. Frigo, and T. E. Darcie, "WDM passive optical network architecture with bidirectional optical spectral slicing," in *Proc. OFC'95*.
- [44] Pablo Molinero, Nick McKeown, Nick McKeown "Is IP going to take over the world (of communications)?" *ACM SIGCOMM Computer Communications Review* Volume 33, Number 1: January 2003
- [45] R. Ramaswami, "Multi wavelength lightwave networks for computer communication," *IEEE Commun. Mag.*, vol. 31, pp. 78–88, Feb. 1993.
- [46] A. Ishimaru, *Electromagnetic Wave Propagation, Radiation, and Scattering*. Englewood Cliffs, NJ: Prentice-Hall, 1991.
- [47] J. P. Powers, *An Introduction to Fiber Optic Systems*. Homewood, IL: Irwin, 1993.
- [48] A. R. Chraplyvy, "Limits on lightwave communications imposed by optical-fiber nonlinearities," *IEEE/OSA J. Lightwave Technol.*, vol. 8, pp. 1548–1557, Oct. 1990.
- [46] I. Tomkos and A. Tzanakaki "Towards Digital Optical Networks" *IEEE Conference Transparent Optical Networks, 2005, Proceedings of 2005 7th International Conference - Publication Date: 3-7 July 2005 Volume: 1, On page(s): 1- 4 Vol.1*

- [47] Samir Chatterjee and Suzanne Pawlowski “All Optical Networks” Communications of the ACM June 1999/Vol. 42, No. 6
- [48] Juan Diao and Pak L. Chu “Analysis of Partially Shared Buffering for WDM Optical Packet Switching” Journal of Lightwave Technology, Vol. 17, No. 12, Dec 1999
- [49] Muriel Médard, Douglas Marquis, and Stephen R. Chinn “Attack Detection Methods for All-Optical Networks” IEEE Conference Optical Fiber Communication Conference and Exhibit, 1998. OFC '98., Technical Digest On page(s): 272-273
- [50] Debashis Saha, Debabrata Sengupta “An Optical Layer Protocol for Lightpath Management in WDM Networks” IEEE Performance, Computing and Communications Conference, 1999. IPCCC '99. IEEE International Publication Date: 10-12 Feb 1999
- [51] Hongqing Zeng and Changcheng Huang “Spanning-Tree Based Monitoring-Cycle Construction for Fault Detection and Localization in Mesh AONs” Communications, 2005. ICC 2005. 2005 IEEE International Conference on Publication Date: 16-20 May 2005 Volume: 3, On page(s): 1726- 1730 Vol. 3
- [52] D. Saha “An Efficient Wavelength Reservation Protocol for Lightpath Establishment in all-optical networks (AONs)” IEEE Global Telecommunications Conference, 2000. GLOBECOM '00. IEEE Publication Date: 2000 Volume: 2, On page(s): 1264-1268 vol.2
- [53] K. Lee and V. O. K. Li, “Optimization of a WDM optical packet switch with wavelength converters,” in Proc. IEEE INFOCOM'95, vol. 2, pp. 423–430.
- [54] Alferness, R.C “The all-optical networks” IEEE Communication Technology Proceedings, 2000. WCC - ICCT 2000. International Conference on Volume 1, 21-25 Aug. 2000 Page(s):14 - 15 vol.1
- [55] Otani, T “All-optical networking testbed demonstration” IEEE Photonics in Switching, 2008. PS 2008. International Conference on 4-7 Aug. 2008 Page(s):1 – 2
- [57] Saleh, A.A.M “All-optical networking in metro, regional and backbone networks” All-Optical Networking: Existing and Emerging Architecture and Applications/Dynamic Enablers of Next-Generation Optical Communications Systems/Fast Optical Processing in Optical Transmission/VCSEL and Microcavity Lasers. 2002 IEEE/LEOS Summer Topi 15-17 July 2002 Page(s):MG3-15
- [58] Pankaj, R.K.; Gallager, R.G “Wavelength requirements of all-optical networks” Networking, IEEE/ACM Transactions on Volume 3, Issue 3, June 1995 Page(s):269 – 280
- [59] Ramaswami, R.; Sivarajan, K.N “Design of logical topologies for wavelength-routed all-optical networks”. INFOCOM '95. Fourteenth Annual Joint Conference of the IEEE Computer and Communications Societies. Bringing Information to People. Proceedings. IEEE 2-6 April 1995 Page(s):1316 - 1325 vol.3
- [60] Saleh, A.A.M “Defining all-optical networking and assessing its benefits in metro, regional and backbone networks”. Optical Fiber Communications Conference, 2003. OFC 2003 23-28 March 2003 Page(s):410 - 411 vol.1
- [62] Gillner, L. “Transmission limitations in the all-optical network” IEEE Optical Communication, 1996. ECOC '96. 22nd European Conference on Volume 2, 15-19 Sept. 1996 Page(s):39 - 44 vol.2

- [63] Sartorius, B. "3R regeneration for all-optical networks" IEEE Transparent Optical Networks, 2001. Proceedings of 2001 3rd International Conference on 18-21 June 2001 Page(s):333 - 337
- [64] Marciniak, M. "Optical transparency in next generation IP over all-optical networks" IEEE Transparent Optical Networks, 2001. Proceedings of 2001 3rd International Conference on 18-21 June 2001 Page(s):329 - 332
- [65] Chunming Qiao; Myoungki Jeong; Guha, A.; Xijun Zhang; Wei, J. "WDM multicasting in IP over WDM networks" IEEE Network Protocols, 1999. (ICNP '99) Proceedings. Seventh International Conference on 31 Oct.-3 Nov. 1999 Page(s):89 – 96
- [66] Opnet SP Guru Transport Planner homepage and documentations:
http://www.opnet.com/solutions/network_planning_operations/spguru_transport_planner.html
- [67] Marcos Rogério Salvador¹, Sonia Heemstra de Groot, Ignas Niemegeers, "Protocol and Networking Design Issues for Local Access WDM Networks," [Online]
<http://www.ub.utwente.nl/webdocs/ctit/1/00000018.pdf>

16. Appendix A

Table I: List of All-Optical Networks in Test Beds

Table I. Sample of major optical networking initiatives in North America and Europe.

Project & Research Group	Key Participants	Focus of work and salient characteristics
Columbia University Lightwave Group (www.ctr.columbia.edu/~georgios/lightwave.html)	Bellcore, AT&T, GTE, Northern Telecom, NEC, Phillips, Southwestern Bell	<ul style="list-style-type: none"> • Goal is to devise new network architectures using state-of-the-art photonic device technologies that can form the basis for a new optical network infrastructure on a national scale • Focus more on a systems-level perspective rather than a pure physical-level and device-level approach • Produce systems-level architecture and new control methodologies appropriate for lightwave networks
IBM Optical Networking Group (www.research.ibm.com/wkm)	Work includes collaborative initiatives with Corning and LANL	<ul style="list-style-type: none"> • Research aims to define the architecture of an optical layer by using multiwavelength WDM technology • IBM and Corning are investigating scalable architectural issues based on WDM or wavelength routing • This group has also been developing the Rainbow-II metropolitan area network deployed in an applications testbed at Los Alamos National Laboratory
ACTS (Advanced Communications Technology and Services Programme) Photonics Projects (www.intec.rug.ac.be/horizon/photonic/html)	The European Union research programs on photonic technology includes industry, academia, and government partners	<ul style="list-style-type: none"> • 31 ACTS projects addressing the concepts, design and management of optical networks, customer access networks, multiplexing and transport, sub-system and key component development, and switching and routing • Major optical networks projects in the Programme include: OPEN, KEOPS, COBNET, METON, PHOTON, MEPHISTO, MOON, PELICAN, DEMON, HORIZON, PLANET, MEPHISTO, and SONATA
All-Optical Networking Consortium (www.ll.mit.edu/aon/)	AT&T Bell Laboratories, Digital Equipment Corporation, and the Massachusetts Institute of Technology sponsored by DARPA	<ul style="list-style-type: none"> • Deployment of a static wavelength routing testbed in the Boston metropolitan area to demonstrate feasibility and interaction of architectures, optical technologies and applications
MONET: Multiwavelength Optical Network (www.bell-labs.com/project/MONET/)	Bellcore, Lucent Technologies, AT&T, Bell Atlantic, BellSouth, Pacific Telesis, Southwestern Bell Technologies Resources, Inc. (In cooperation with NSA/NRL; partial support from DARPA)	<ul style="list-style-type: none"> • Objective is to integrate network architecture, advanced technology, network management, and business drivers to achieve high capacity, high performance, cost-effective, reliable, transparent multiwavelength optical networking • Develop an understanding of operational issues associated with network deployment
NTONC: National Transparent Optical Network Consortium (www.ntonc.org/)	Nortel Networks, GST Telecom, Lawrence Livermore National Laboratory, Sprint Communications Company (DARPA sponsorship)	<ul style="list-style-type: none"> • Development of an advanced optical networking research testbed running from San Diego to Seattle, with nodes in Los Angeles, San Francisco, and Portland; and an optically switched ring around the San Francisco Bay • Provide a field test environment for high-bandwidth applications • Examine "flat network architecture" a meshed network with dynamically adjustable link capacities and nodes that provide data packaging into "containers" for transport

17. Appendix B

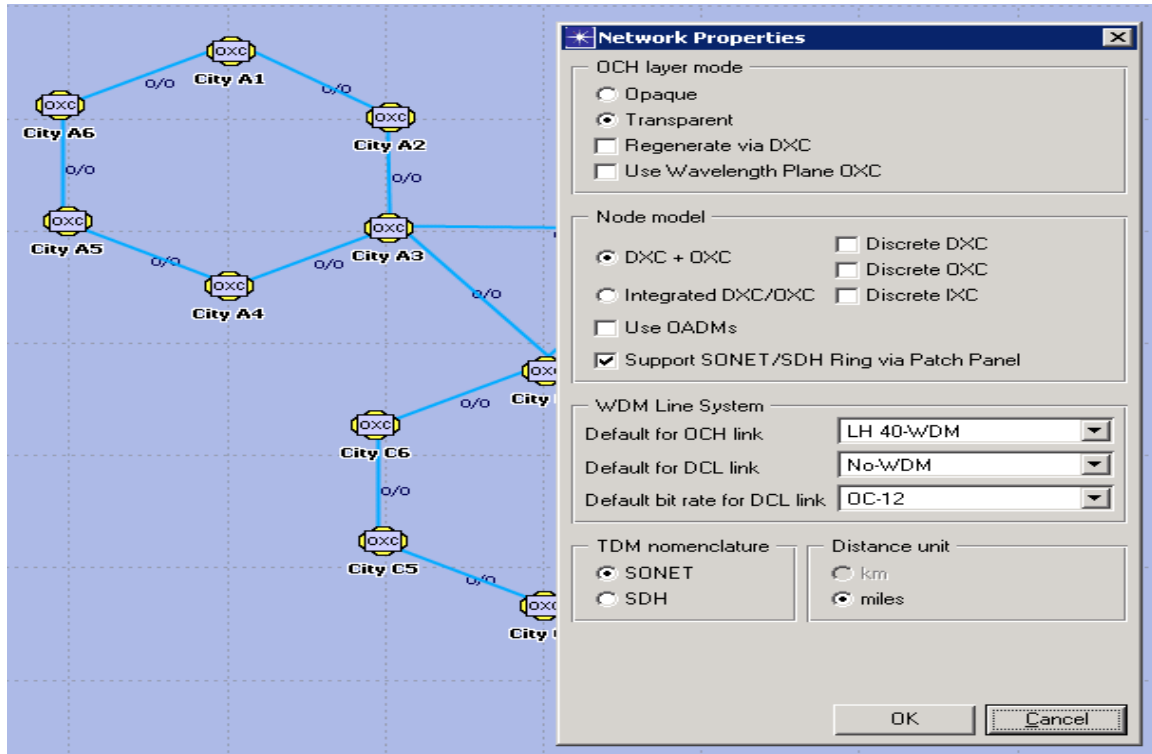

Diagram I: Setting up network properties

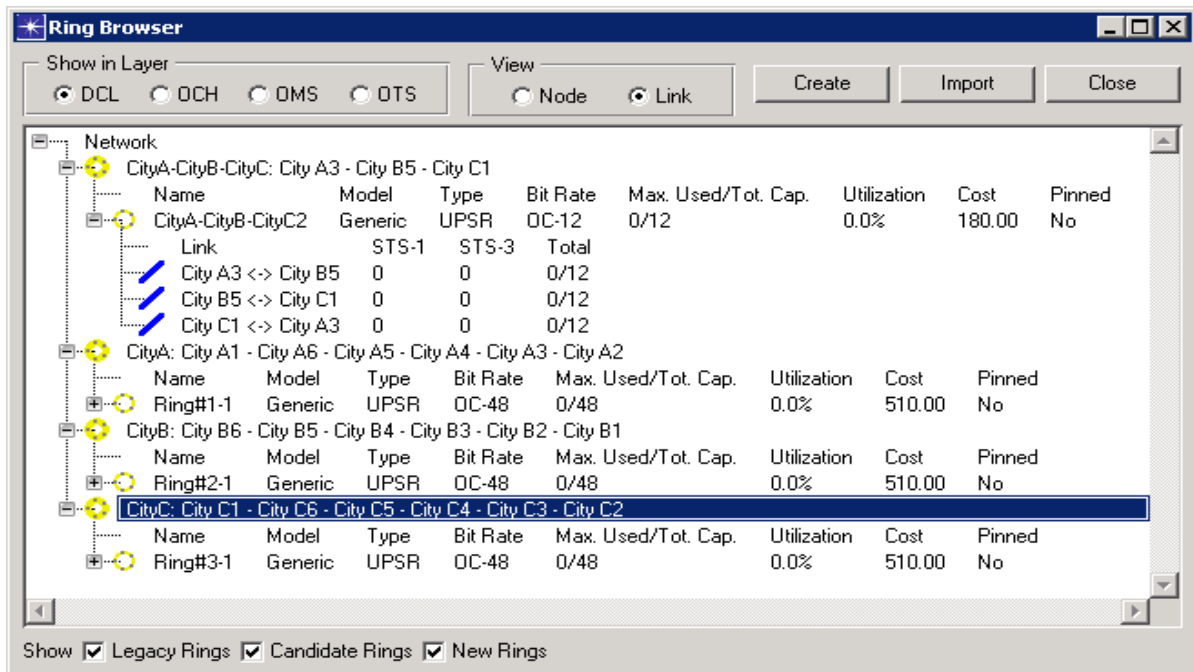

Diagram II: Ring browser creating ring properties

Layer: DCL OCH OMS OTS

Name	Fiber Pairs	Reg. Stations	OA Stations	Length	Delay	Designed	User Cost
City A1 <-> City A2 (1)	50	0	0	142.6 miles	0.713 ms	No	0.00
City A1 <-> City A6 (1)	50	0	0	151.3 miles	0.757 ms	No	0.00
City A3 <-> City A2 (1)	50	0	0	123.0 miles	0.615 ms	No	0.00
City A3 <-> City B5 (1)	80	0	0	247.0 miles	1.235 ms	No	0.00
City A4 <-> City A3 (1)	50	0	0	144.9 miles	0.725 ms	No	0.00
City A5 <-> City A4 (1)	50	0	0	153.4 miles	0.767 ms	No	0.00
City A6 <-> City A5 (1)	50	0	0	118.0 miles	0.590 ms	No	0.00
City B1 <-> City B2 (1)	50	0	0	142.6 miles	0.713 ms	No	0.00
City B1 <-> City B6 (1)	50	0	0	151.3 miles	0.757 ms	No	0.00
City B3 <-> City B2 (1)	50	0	0	123.0 miles	0.615 ms	No	0.00
City B4 <-> City B3 (1)	50	0	0	144.9 miles	0.725 ms	No	0.00
City B5 <-> City B4 (1)	50	0	0	153.4 miles	0.767 ms	No	0.00
City B5 <-> City C1 (1)	80	0	0	202.8 miles	1.014 ms	No	0.00
City B6 <-> City B5 (1)	50	0	0	118.0 miles	0.590 ms	No	0.00
City C1 <-> City A3 (1)	80	0	0	202.3 miles	1.011 ms	No	0.00
City C1 <-> City C2 (1)	50	0	0	142.6 miles	0.713 ms	No	0.00
City C1 <-> City C6 (1)	50	0	0	151.3 miles	0.757 ms	No	0.00
City C3 <-> City C2 (1)	50	0	0	123.0 miles	0.615 ms	No	0.00
City C4 <-> City C3 (1)	50	0	0	144.9 miles	0.725 ms	No	0.00
City C5 <-> City C4 (1)	50	0	0	153.4 miles	0.767 ms	No	0.00
City C6 <-> City C5 (1)	50	0	0	118.0 miles	0.590 ms	No	0.00

Show designations Show fibers Show in-line sites Close

Diagram III: Setting up the properties of links

0 Regeneration sites added;
1 OA sites added at 100 miles;

Performed link design on City C6 <-> City C5 (1) (length = 118.038):
0 Regeneration sites added;
1 OA sites added at 100 miles;

Performed link design on City C5 <-> City C4 (1) (length = 153.395):
0 Regeneration sites added;
1 OA sites added at 100 miles;

Performed link design on City C4 <-> City C3 (1) (length = 144.917):
0 Regeneration sites added;
1 OA sites added at 100 miles;

Performed link design on City C3 <-> City C2 (1) (length = 123.016):
0 Regeneration sites added;
1 OA sites added at 100 miles;

Performed link design on City C1 <-> City C2 (1) (length = 142.58):
0 Regeneration sites added;
1 OA sites added at 100 miles;

Performed link design on City C1 <-> City A3 (1) (length = 202.252):
0 Regeneration sites added;
2 OA sites added at 100, and 200 miles;

Performed link design on City A3 <-> City B5 (1) (length = 247.018):
0 Regeneration sites added;
2 OA sites added at 100, and 200 miles;

Performed link design on City B5 <-> City C1 (1) (length = 202.8):
0 Regeneration sites added;
2 OA sites added at 100, and 200 miles;

Close

Diagram IV: Regenerators and optical amplifiers added on links

Overview

Used Traffic Matrices

Traffic Matrix	Newly Routed Connections	Total Routed Connections	Demanded Connections	Percent Routed	Total Hops of Working Paths	Mean Hops of Working Paths
OCH_Uniform5	765	765	765	100.0	2,565	3.353

Utilization

Variable	Value
OCH Used Link Capacity	2,565 wavelengths
OCH Equipped Link Capacity	3,600 wavelengths
OCH Link Utilization	71.25%
OCH Node Utilization	9.03%

Diagram V: OOO Network Performance with Uniform Traffic Matrix (5)

Overview

Used Traffic Matrices

Traffic Matrix	Newly Routed Connections	Total Routed Connections	Demanded Connections	Percent Routed	Total Hops of Working Paths	Mean Hops of Working Paths
OCH_Uniform10	1,530	1,530	1,530	100.0	5,130	3.353

Utilization

Variable	Value
OCH Used Link Capacity	5,130 wavelengths
OCH Equipped Link Capacity	6,840 wavelengths
OCH Link Utilization	75.0%
OCH Node Utilization	18.07%

Diagram VI: OOO Network Performance with Uniform Traffic Matrix (10)

Overview

Used Traffic Matrices

Traffic Matrix	Newly Routed Connections	Total Routed Connections	Demanded Connections	Percent Routed	Total Hops of Working Paths	Mean Hops of Working Paths
OCH_Uniform20	3,060	3,060	3,060	100.0	10,260	3.353

Utilization

Variable	Value
OCH Used Link Capacity	10,260 wavelengths
OCH Equipped Link Capacity	13,200 wavelengths
OCH Link Utilization	77.73%
OCH Node Utilization	36.13%

Diagram VII: OOO Network Performance with Uniform Traffic Matrix (20)

Overview

Used Traffic Matrices

Traffic Matrix	Newly Routed Connections	Total Routed Connections	Demanded Connections	Percent Routed	Total Hops of Working Paths	Mean Hops of Working Paths
OCH_Uniform50	7,200	7,200	7,650	94.12	23,750	3.299

Utilization

Variable	Value
OCH Used Link Capacity	23,750 wavelengths
OCH Equipped Link Capacity	29,960 wavelengths
OCH Link Utilization	79.27%
OCH Node Utilization	74.27%

Diagram VIII: OOO Network Performance with Uniform Traffic Matrix (50)

Overview

Used Traffic Matrices

Traffic Matrix	Newly Routed Connections	Total Routed Connections	Demanded Connections	Percent Routed	Total Hops of Working Paths	Mean Hops of Working Paths
OCH_Uniform100	9,400	9,400	15,300	61.44	24,700	2.628

Utilization

Variable	Value
OCH Used Link Capacity	24,700 wavelengths
OCH Equipped Link Capacity	31,120 wavelengths
OCH Link Utilization	79.37%
OCH Node Utilization	79.91%

Diagram IX: OOO Network Performance with Uniform Traffic Matrix (100)

Overview

Used Traffic Matrices

Traffic Matrix	Newly Routed Connections	Total Routed Connections	Demanded Connections	Percent Routed	Total Hops of Working Paths	Mean Hops of Working Paths
Uniform5	765	765	765	100.0	2,565	3.353

Utilization

Variable	Value
OCH Used Link Capacity	2,565 wavelengths
OCH Equipped Link Capacity	3,600 wavelengths
OCH Link Utilization	71.25%
OCH Node Utilization	20.65%

Diagram X: OEO Network Performance with Uniform Traffic Matrix (5)

Overview

Used Traffic Matrices

Traffic Matrix	Newly Routed Connections	Total Routed Connections	Demanded Connections	Percent Routed	Total Hops of Working Paths	Mean Hops of Working Paths
Uniform10	1,530	1,530	1,530	100.0	5,130	3.353

Utilization

Variable	Value
OCH Used Link Capacity	11,545 wavelengths
OCH Equipped Link Capacity	14,760 wavelengths
OCH Link Utilization	78.22%
OCH Node Utilization	40.76%

Diagram XI: OEO Network Performance with Uniform Traffic Matrix (10)

Overview

Used Traffic Matrices

Traffic Matrix	Newly Routed Connections	Total Routed Connections	Demanded Connections	Percent Routed	Total Hops of Working Paths	Mean Hops of Working Paths
Uniform20	2,832	2,832	3,060	92.55	8,900	3.143

Utilization

Variable	Value
OCH Used Link Capacity	20,445 wavelengths
OCH Equipped Link Capacity	27,200 wavelengths
OCH Link Utilization	75.17%
OCH Node Utilization	66.4%

Diagram XII: OEO Network Performance with Uniform Traffic Matrix (20)

Overview

Used Traffic Matrices

Traffic Matrix	Newly Routed Connections	Total Routed Connections	Demanded Connections	Percent Routed	Total Hops of Working Paths	Mean Hops of Working Paths
Uniform50	2,723	2,723	7,650	35.59	6,803	2.498

Utilization

Variable	Value
OCH Used Link Capacity	27,248 wavelengths
OCH Equipped Link Capacity	40,080 wavelengths
OCH Link Utilization	67.98%
OCH Node Utilization	97.56%

Diagram XIII: OEO Network Performance with Uniform Traffic Matrix (50)

Overview

Used Traffic Matrices

Traffic Matrix	Newly Routed Connections	Total Routed Connections	Demanded Connections	Percent Routed	Total Hops of Working Paths	Mean Hops of Working Paths
Unifrom100	2,731	2,731	15,300	17.85	4,558	1.669

Utilization

Variable	Value
OCH Used Link Capacity	31,806 wavelengths
OCH Equipped Link Capacity	42,480 wavelengths
OCH Link Utilization	74.87%
OCH Node Utilization	98.0%

Diagram XIV: *OEO Network Performance with Uniform Traffic Matrix (100)*