

Rochester Institute of Technology

RIT Digital Institutional Repository

Theses

12-2021

The use of Reverse Vending Machine (RVM) for less plastic in Dubai

Sarah Obaid Al Shamsi
soa2787@rit.edu

Follow this and additional works at: <https://repository.rit.edu/theses>

Recommended Citation

Al Shamsi, Sarah Obaid, "The use of Reverse Vending Machine (RVM) for less plastic in Dubai" (2021). Thesis. Rochester Institute of Technology. Accessed from

This Master's Project is brought to you for free and open access by the RIT Libraries. For more information, please contact repository@rit.edu.

The use of Reverse Vending Machine (RVM) for less plastic in Dubai

by

Sarah Obaid Al Shamsi

**A Capstone Submitted in Partial Fulfilment of the Requirements for
the Degree of Master of Science in Professional Studies:**

Smart Cities

Department of Graduate Programs & Research

Rochester Institute of Technology

RIT – Dubai

Dec 2021

RIT

Master of Science in Professional Studies: Smart Cities

Graduate Capstone Approval

Student Name:

Sarah Obaid Al Shamsi

Graduate Capstone Title:

The use of Reverse Vending Machine (RVM) for less plastic in Dubai

Graduate Capstone Committee:

Name: Dr. Sanjay Modak

Date:

Chair of committee

Name: Dr. Khalil Al Hussaeni

Date:

Member of committee

Acknowledgments

I would like to thank my family for their endless support, especially my husband who supported me in every step through this journey.

I wish to extend my special thanks to my mentor, Dr. Khalil Al Hussaeni, who guided me through this project, and supported me in every step.

Furthermore, I would like to thank my professors for their time, effort, and endless support during this program.

Finally, I would like to thank RIT for giving me the chance to continue my higher education in the hard times of Covid-19, where many around the world could not continue their education.

Abstract

Plastic pollution is affecting negatively on the environment, it affects trees, animals, marine life, and even humans. One of the most common plastic types is plastic bags, it is widely spread due its special characteristics such as light weigh, and cheap price. In Dubai City, plastic bags are widely used especially in the supermarkets, with the increase in the population of Dubai, the number of plastic bags will increase and the impacts will be more appearance. Dubai City is a leading city in the region for its ability to change and adapt with new strategies that serves the citizen and the environment as a whole. In this project, plastic bags issue in Dubai will be studied and analyzed, beside suggesting a possible solution for this problem. The research will focus on the size of the problem and how it is affecting the environment from different aspects. Moreover, the study will use a descriptive analysis to provide a deep look at the problem. Furthermore, a secondary study will be used to help with supporting the solution. The suggested solution in this study is using reverse vending machines (RVM) in one of the biggest supermarkets in Dubai, which is Union-Coop supermarket. The research focuses on a solution that matches the vision of Dubai, towards utilizing and harnessing the technology to make citizens life easier, and save the environment from misuse of resources.

Keywords: Plastic pollution, Plastic bags, Supermarkets, Reverse Vending Machine (RVM), Recycling, Dubai, Technology.

Table of Contents

Acknowledgments	iii
Abstract.....	iv
List of figures.....	vi
List of tables.....	vi
Chapter 1	1
1.1 Background of the Problem	1
1.2 Statement of Problem	4
1.3 Project goals	4
1.4 Methodology	5
1.5 Limitation of the Study.....	6
Chapter 2 - Literature Review.....	7
Chapter 3 - Project Analysis	14
<i>Project Description</i>	14
<i>Plastic and paper recycling in Dubai</i>	15
<i>Union-Coop Supermarkets</i>	16
<i>Number of plastic bags used in Union-Coop Supermarket</i>	17
<i>Carbon emissions produced by plastic bags</i>	17
<i>Calculating carbon emissions produced by plastic bags used in Union-coop Supermarkets.</i> ..	17
<i>RVM as a solution</i>	18
<i>Proposed RVM machine</i>	20
<i>Reason behind using RVM machines</i>	21
<i>A study on the behavior of citizens towards using RVM</i>	22
Chapter 4	25
4.1 Conclusion	25
4.2 Recommendations	25
4.3 Future work.....	26
References	27

List of figures

Figure 1: World plastic production from 1950 to 2015.....	1
Figure 2: Total MSW Generations.....	8
Figure 3: The hypothesis stated by the authors that plastic bags are harmful for the agriculture.....	9
Figure 4: Waste Management hierarchy (WMH).....	11
Figure 5: Samples of plastic concrete blocks.....	11
Figure 6: Plastic waste recycling in Dubai according to Dubai Municipality.....	15
Figure 7: Paper waste recycling in Dubai according to Dubai Municipality.....	16
Figure 8: Union-Coop branches map as shown in Google maps.....	19
Figure 9: Design of the proposed reverse vending machine (RVM)	20
Figure 10: Education level effect on recycling rate.....	23
Figure 11: Types of motivations that respondents prefer while using RVM.....	24

List of tables

Table1: Average number of plastic units used by business sector per month, Trinidad and Tobago.....	7
Table 2: Carbon emissions produced by Union-coop Supermarket.....	18

Chapter 1

1.1 Background of the Problem

Plastic in the world

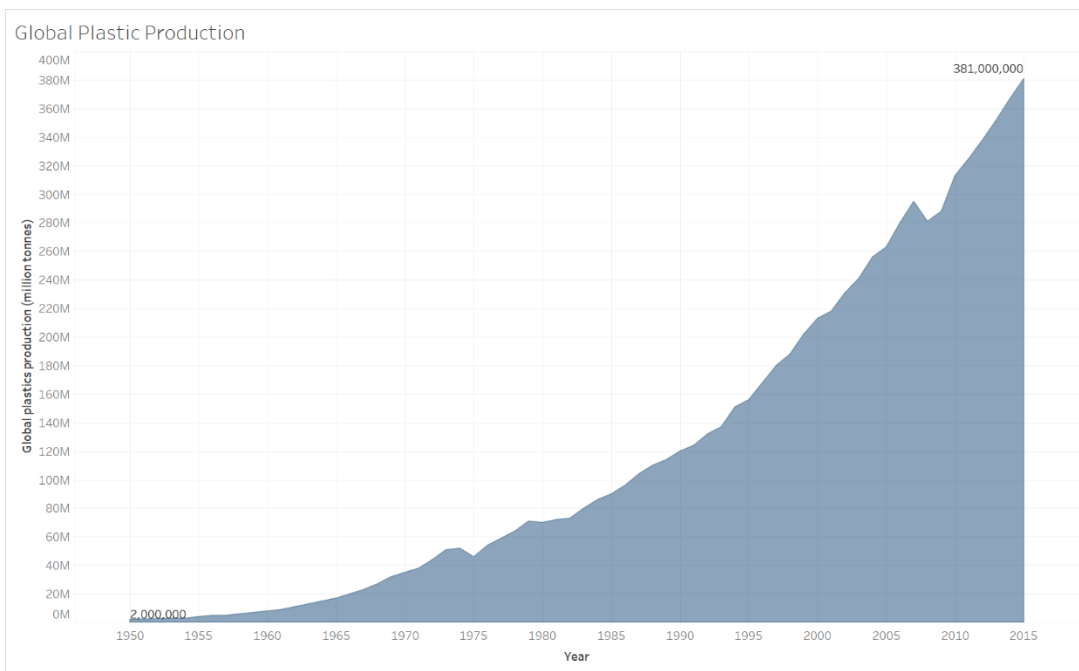

Figure 1: World plastic production from 1950 to 2015 (Ritchie, 2018)

Plastic is found around us in huge quantities, it is used for material packaging, carrying different things, and other practices such as protecting surfaces. The continuous increase in the world's population leads to the increase in the solid waste such as plastic waste. As we can see from figure1, plastic production was about 2 million tons in the year of 1950, and it increased to reach 381 million tons by 2015. This is considered as a massive change in production that led to a noticeable effect on the ecosystem (Ritchie, 2018).

Plastic in the ocean

In the ocean, plastic can be found with huge amounts and quantities. It is considered to be one of the most issues that threatens marine life (PARKER, 2019). While 8% of the plastic in the ocean breakout to be microplastic along the years, over 90% of it keep floating in the ocean. An estimation done in 2015 of the amounts of plastic in the ocean, the result showed that about 150 million metric tons of plastic are polluting the ocean and they are responsible for the death of 80 different species (Readfearn, 2020). Number of plastics in oceans is expected to reach 600 million metric tons by 2040. (PARKER, 2019)

Plastic bags in the world

Plastic bags are consumed in huge amounts during the day. People are using plastic bags to carry different things such as groceries, food, and other things. An average of 160,000 plastic bags are used every second in the world (forbes, 2020). This means that about 5 trillion plastic bags are used yearly. It is surprising to know that only 3% of these bags are being recycled, and the rest remains on earth for 10 to 100 years (Sedaghat, 2018). Plastic bags are made from fossil fuel and other oil derived substances. In the decomposition of plastic bags, greenhouse gases are released, these gases accumulate in the air and causes air pollution that leads to the increase of climate change phenomenon (Vasarhelyi, 2021).

Population growth in Dubai

Dubai is considered as a leading city in the gulf region for its vision to be a global city. It gathers different nationalities from different continents. According to Dubai Statistics Center, Dubai population reached 3,411,200 in 2020 with a growth rate of 1.63% (DSC, 2021). Many factors attributed in this increase in population of Dubai, such as the livability of the city, the quality of services provided by the government, and the business movement that attracts people from around the world.

Plastic in Dubai

In the UAE, 11 billion plastic bags are used yearly, this means that each person is consuming around 1,130 plastic bags each year. In Dubai, the total consumption of plastic bags reached above 3 billion bags yearly (emirates247, 2013). The plastic recycling rate in the UAE is lower than other materials, only 4% of the used plastic is recycled (PAULSEN, 2020). As the whole world is threatened by plastic accumulation, Dubai suffers from plastic accumulation too. A study done by the environmental scientist Dr. Marcus Erikson, and the veterinary microbiologist Dr. Ulrich Warney showed that after investigating the different reasons of camel's death, the study reveals that between 30,000 dead camels, 300 died as a result of ingestion plastic items and specifically plastic bags. After ingestion the plastic, it starts to impede the digestion system from working normally, at the end it blocks the intestine and cause a bacterial infection that leads to death (HANEY, 2020).

1.2 Statement of Problem

In Dubai, plastic is used widely specially in supermarkets. As the population of Dubai is increasing day by day, plastic consumption will increase and the negative impacts of plastic waste will be more noticeable. This project is focusing on the study and the analyses of plastic bags use in Dubai. It aims to find a suitable solution to limit plastic bags use and increase plastic recycling in Dubai.

1.3 Project goals

- 1- Study and analyze the issue of plastic bags waste in Dubai.
- 2- Explore the use of plastic bags in big supermarkets in Dubai.
- 3- Study the environmental impacts of using plastic bags.
- 4- Find a suitable solution for plastic bags waste in Dubai

1.4 Methodology

Research Design

The research design used in the project is descriptive research as the studied environment is not affected. This type of research design helps the researcher with being aware of the issue without making changes to it. Descriptive design enhances the understanding of the problem by asking multiple questions such as: Why? Who? When? All of these questions enable the researcher to have a better understanding of the idea in order to get to the best solution.

Qualitative Research

The research is done based on qualitative analysis, where many factors are studied in the research environment that cannot be provided by quantitative analysis. The acceptance of the society, the ability to change, and the customer behavior, are some of the factors that can be studied through a qualitative analysis.

Sources of Data for the Project

In this project, many data and information were extracted from reliable sources such as government and authorities' websites, to help with having a clear picture of the problem and to find the most suitable solution. There was a need for data to have a clear idea about plastic waste in Dubai. Some collected data about plastic recycling were provided by Dubai Municipality, these data have been studied and analyzed in the research. Other information was provided through email by Union-coop supermarkets in Dubai to help in understanding the consumption of plastic bags among the supermarkets.

Secondary data

Secondary data is a possible method used in researches and studies that allow the researcher to rely on data from other source and reflect it on the research of his own. Data such as datasets, tables, and figures are extracted and analyzed from secondary data source. In this project, the data were extracted from research done in Kazakhstan on the integration of RVM in waste management system, and to study the behavior of citizens towards using RVM.

1.5 Limitation of the Study

There were different limitations to this research such as lack of data sources about waste in Dubai. Moreover, some entities have not published any updated data since more than 10 years, which is considered as huge gap between what happened years ago and today. Furthermore, lack of data forces the research to rely on secondary data and researches that have been implemented in another country. In addition, most of the published data was talking about the issue in a scientific way, only few have studied the problem from a customer or a society point of view.

Chapter 2 - Literature Review

Plastic waste is a big concern in most of the cities around the world, people from different countries are working to find a suitable solution for plastic waste problem. Some prefers recycling of plastic, while others consider replacing plastic with other materials as the best solution.

A case study about “Economic implications of the ban on single-use plastics in the Caribbean” showed that supermarkets in Trinidad and Tobago are considered as a high consumer of plastic, especially plastic bags (Phillips, 2020). The study showed that the average number of white-medium plastic bags used in the supermarkets per month is the highest with 15000 plastic-bag compared to a bakery, food manufacturer, and restaurants.

The solution that they have implemented is about banning single-use plastic. In this way they are forcing all related sectors to move towards a clean, recyclable and eco-friendly replacement.

Paper bags were the replacement of plastic bags, they affected the total monthly operating cost in supermarkets by 532 011 TTD. Their solution was good for the environment, but from economic perspective it increases the cost by 9.6% to 16.9% across different business sectors including supermarkets (Phillips, 2020).

Product	Material	Bakery	Caterer	Food manufacturer	Restaurant	Supermarket	Vegetable Market
Burger Containers	Styrofoam	500	200	50	600	600	50
Straws (long)	Plastic	500	200	50	1000	300	50
Spoons	Plastic	500	200	50	1000	300	50
Forks	Plastic	500	200	50	1000	300	50
Plates (large)	Plastic	450	200	50	600	200	30
Plates (small)	Plastic	450	200	50	600	200	30
Plates (small)	Styrofoam	600	350	50	800	2400	50
Plates (large)	Styrofoam	600	350	50	800	2400	50
Bowls (small)	Plastic	600	100	50	600	1000	-
Food containers (medium)	Styrofoam	500	350	50	800	4000	50
Food containers (large)	Styrofoam	600	350	50	800	4000	50
Food containers (small)	Plastic	500	200	1500	400	4000	-
Food containers (large)	Plastic	800	200	1500	400	4000	-
White bags (medium)	Plastic	6000	500	1500	800	15000	300

Table1: Average number of plastic units used by business sector per month, Trinidad and Tobago 2020 (Willard Phillips, 2020)

According to a study published by WPI about “Reduce, Reuse, and Replace: A study on solutions to plastic wastes”, plastic is responsible for 11.7% of the municipal solid waste (MSW) in the United States as shown in figure 2 (Li, 2009). Moreover, the study mentioned that although the percentage of the plastic in MSW is not that high, but it has the lowest rate of recycling and recovery among other materials such as glass and metals.

The study suggested many solutions for over plastic production, one of the solutions was chemical decomposing. They suggest to develop a technology that helps in converting plastic into non-harmful particles as this will be a good solution on the economic and environmental level. The study gives many reasons behind this solution, such as the cheap production of the plastic, the easy transportation of the plastic as it occupies less space compared to other materials like fabric and paper. In addition, it pays attention to the workers in plastic industries, many will lose their job if plastic production has stopped.

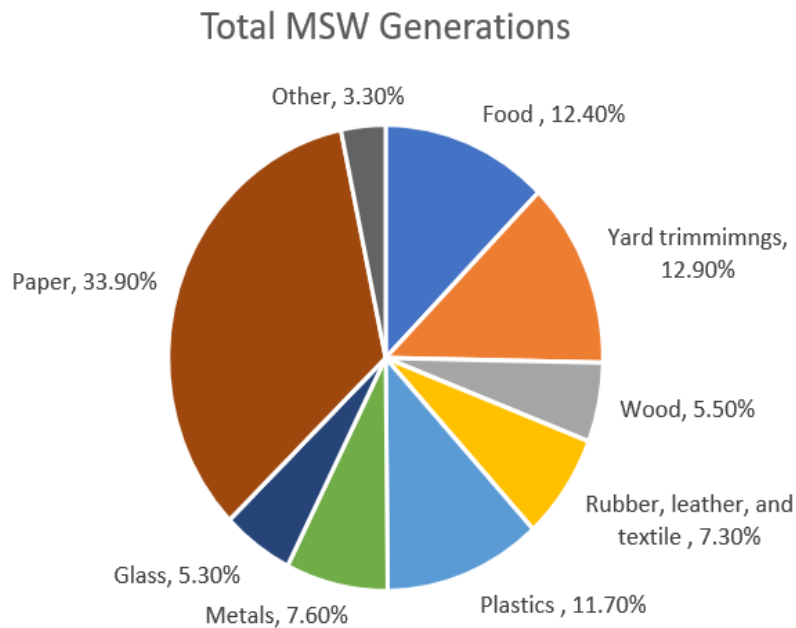

Figure 2: Total MSW Generations - Municipal Solid Waste Generation, Recycling and Disposal in the United States (Ningwei Li, 2009)

A study in Nigeria, specifically in the Federal University of Technology emphasized that with the enormous increase in the number of produced plastics, and the different land, ocean, and sea pollution. The objective of the study was to analyze the effect of plastic bags increase on agriculture, and to find a solution for this problem.

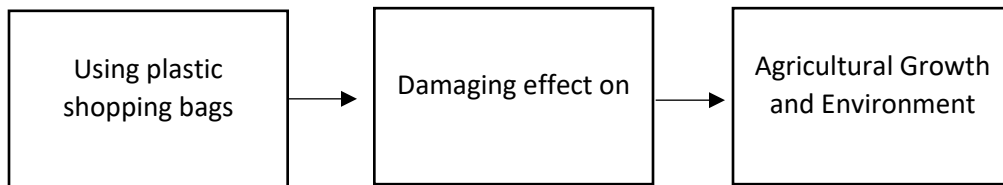

Figure 3: The hypothesis stated by the authors that plastic bags are harmful for the agriculture. (Nannu Mian, 2013)

One of the examples for plastic problems that were mentioned in the study was how plastic can prevent a plant from growing. Plastic bags stay for a long time in the soil, it blocks the roots growing and therefore interrupts the lifecycle of the plant. One of the most important solutions is increasing people awareness of this topic beside other solutions such as using bioplastics (Okunola A Alabi, 2019). Nannu Mian from University of Bangladesh, and Muhammad Khalilur Rahman from University of Malaysia, suggested many solutions to overcome this problem. One of the solutions was to replace plastic bags with jute bags as they are biodegradable, eco-friendly, cheap, and heavy-duty bags (Mian, 2013).

A study about “Solutions and Integrated Strategies for the Control and Mitigation of Plastic and Microplastic Pollution” showed that the misuse and the mismanagement of using plastic has led to noticeable plastic pollution. Plastic pollution is causing a huge harm to the environment and the living creatures, it is harmful for humans, animals, plants, and organisms. The authors studied the possible improvements in plastic production, plastic disposal, and consumption which can reduce the effects of plastic pollution on the entire ecosystem (Prata, 2019).

The Article “Plastic Prohibition: The Case for A National Single-Use Plastic Ban in The United States” highlights the huge impact of single use plastic bags on the environment, and the problem of plastic recycling. In the United States, only 9.1% of plastic is being recycled. In addition, only 1% of plastic bags is being recycled. Recently, eight states banned the use of single-use plastic which are: California, Connecticut, Delaware, Hawaii, Maine, New York, Oregon, and Vermont. Moreover, not all plastics are recyclable, some types of plastics are hard to process and it cause machines damages. For that reason, US and other countries were exporting plastic waste to another countries in order to sort it and recycle it, the biggest country in this field was China. In 2018, China stopped the importing of plastic wastes because a huge percent of it cannot be recycled, and it ends in the landfills and causes more environmental issues. This made it harder for the countries that used to export plastic wastes to China, such as US, so they are studying a plan to expand the ban of single use plastic bags (Kolcon, 2021). China is considered as the largest global industry for plastic with 29%, whereas Japan has a small share of 4% in plastic bags industry. The total plastic production worldwide reached 335 million tons in 2020, although the pandemic was on its peak, plastic industry kept increasing (Zjup, 2019). As a result of banning plastic waste imports in China, many countries reconsidered plastic production and plastic recycling. Furthermore, EU released different strategies to eliminate plastic waste such as restrict use of microplastics and single use plastics.

The article “A Look at Plastic Bags and Alternatives” emphasizes on the importance of using waste management hierarchy, it must be followed in order to avoid waste and reduce its impacts on the environment. The figure below shows waste management hierarchy. The study suggested the use of paper bags as an alternative for one use plastic bags as they can be produced using different fiber materials depending on their use. Paper bags as preferred because the percentage of the recycling of paper around the world is high, it reaches about 58% from the total recycled materials. Moreover, the study suggests other replacements such as tote bags, jute bags, and biodegradable bags (Oji, 2020).

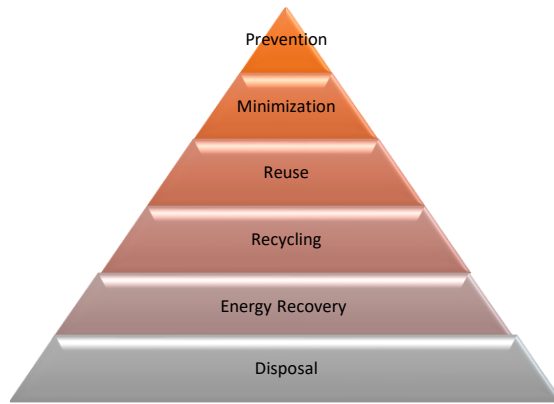

Figure 4: Waste Management hierarchy (WMH)
(Samuel Oji, 2020)

According to the article “Recycling Waste Plastic Bags as a Replacement for Cement in Production of Building Bricks and Concrete Blocks”, the special characteristics of plastic gave it an advantage over other materials as its waterproof, low cost, and suitable for carrying different objects. These characteristics makes plastics hard to be replaced, therefore the study focused on finding different ways to recycle this plastic instead of replace it with another material. A suggested solution was to use plastic in constructions, this will be done through producing concrete blocks, and bricks using sand and waste plastics.



Figure 5: Samples of plastic concrete blocks (Hassanien, 2020).

They found that the amount of waste plastics used in making concrete blocks and plastic bricks, is affecting their thermal conductivity. By increasing the number of plastic wastes, the thermal conductivity decreases (Hassanien, 2020).

According to the article “Integrated Plastic Waste Management: Environmental and Improved Health Approaches”, there are concerns about plastic waste and plastic recycling worldwide. The need for waste management systems is increasing day by day. Plastic has different advantages over other materials due to its easy production. As the population is increasing rapidly, plastic consumption is also increasing. In order to help with plastic waste management, countries around the world must have a dataset to monitor plastic waste in each country. Moreover, any lack of data will affect the global recording about plastic waste management. Waste management reflects a good picture of any city around the world, until now there are some countries that lack a good waste management system which affects the public health of the society. The challenge is more serious nowadays, because waste has different forms rather than food waste, it can be plastic packaging, different forms of paper, and electronic devices. The global attention goes for plastic waste more than other types of waste due to its non-biodegradability, and its huge effect on the environment. The study suggests to increase the awareness of the negative impacts of plastics among the society, as well as enhancing the technology used in plastic waste recycling by following a coding system that makes the segregation of each type of plastic simple and easy (Singh, 2015).

The spread of Covid-19 had different impacts on many sectors and industries. According to the article “Challenges and strategies for effective plastic waste management during and post COVID-19 pandemic”, the pandemic led to the increase of plastic consumption around the world. Plastic was used widely during the pandemic, it was used for precautionary practices such as protecting surfaces, goods packaging, and human protection (such as single use plastic gloves in supermarkets). As a result of the precautionary practices around the world, some countries such as the United States have suspended the recycling process in order to contain the spread of the pandemic in recycling centers. Moreover, many environmental summits were postponed during the pandemic, as a result of this delay, many countries have shifted their agendas towards environmental health for a longer time. Looking at all of these practices, we can say that waste in general will increase in huge amounts in the coming years.

European Union promised to make at least 25% of its uses of plastic during the pandemic made of eco-friendly materials. The study emphasizes on the roles of personal behaviors and social institutional awareness to overcome this problem (Vanapalli, 2021).

As we can see, solutions are different from country to another, many factors control plastic waste management such as the economy of the country, and the amount of plastic waste data in each country. Some countries have already started the journey towards banning single use plastic bags, while other countries focus on improving the recycling methods of plastic and make it more efficient with minimum dangers for the ecosystem as a whole.

Chapter 3 - Project Analysis

Project Description

The research starts with highlighting the problem of plastic in the world, and how it is affecting the world and the environment. Then it studies the problem of plastic bags in Dubai, and how the increase of population is affecting it.

Moreover, it studies different researches that have been done in the field of plastic, plastic waste, and plastic bags waste, and the different solutions of this problem. The researches techniques are different from a researcher to another according to the purpose of the research, as well as the introduced solutions for plastic bags, and plastic waste issue.

Furthermore, the research is done through descriptive research. The analysis done in this research for different data from multiple sources will help in providing a better understanding for the problem, and to suggest a suitable solution for it. A secondary data will be used to help in providing data about customer behavior, as these data are not available in Dubai. The findings of the analysis for the secondary data will be reflected on Dubai to help with creating a comprehensive picture of the possibilities.

The proposed solution in this project is integrating RVM in one of the biggest supermarkets in Dubai, which is Union-coop. The machine will help in increasing the recycling of plastic bags, saving effort and money for recycling centers, and benefiting the customer by providing discounts for each amount of inserted recyclable material.

Plastic and paper recycling in Dubai

Using data provided by Dubai Municipality about plastic recycling done in the recycling center of Dubai Municipality only, the research found that the recycling of plastic waste has a slight decrease in 2020 compared to 2021. This may be as a result of the spreading of covid-19, and the increase of plastic used for protection purposes.

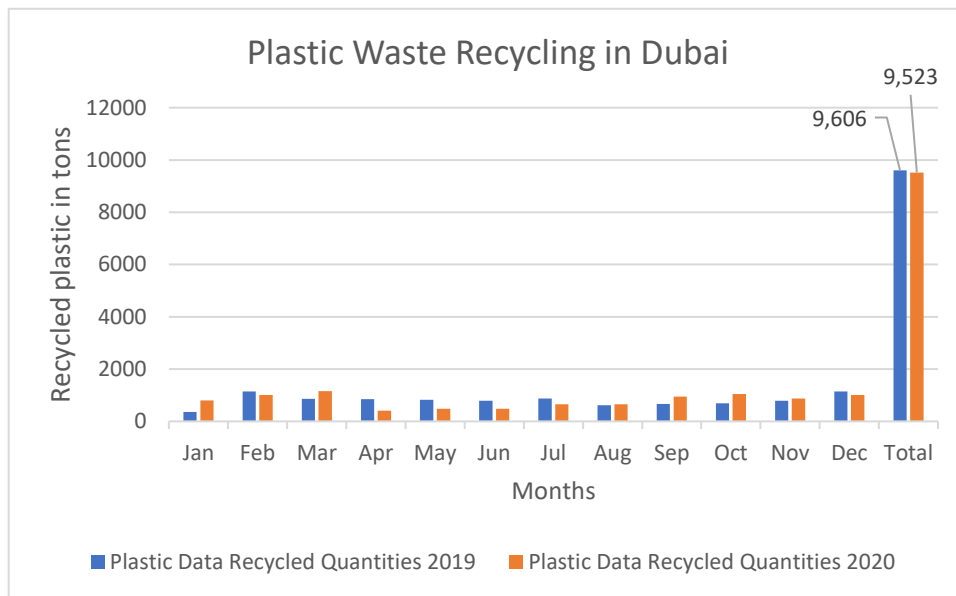

Figure 6: Plastic waste recycling in Dubai according to Dubai Municipality (DM, 2021)

Using data provided by Dubai Municipality about paper recycling in Dubai, the research found that paper waste recycling in Dubai has increased from 14,627 tons to 14,989 tons between 2019 to 2020 (DM, 2021).

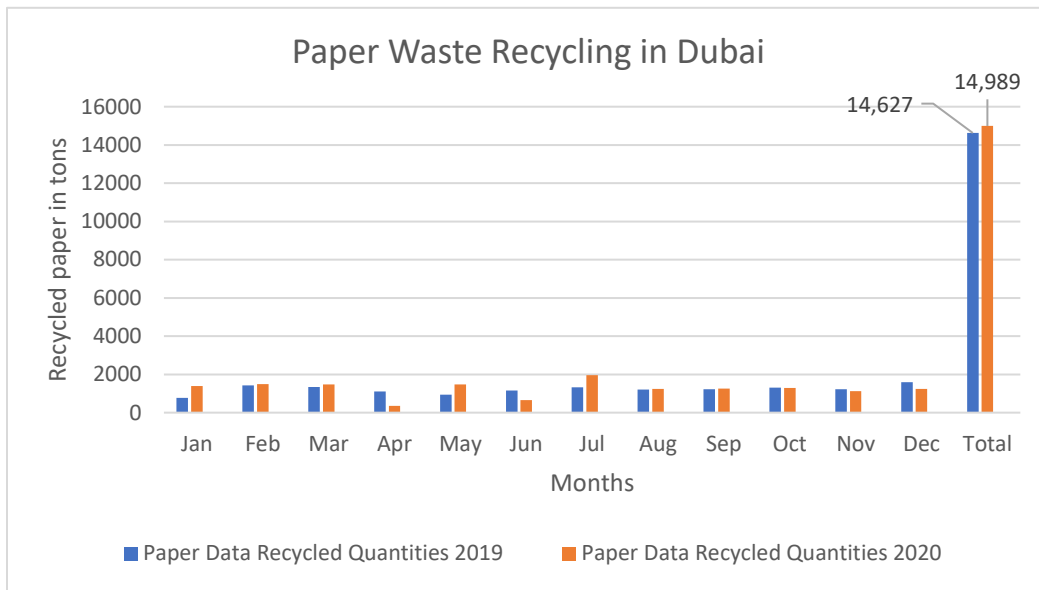

Figure 7: Paper waste recycling in Dubai according to Dubai Municipality (DM, 2021)

From the two graphs, we can see that paper waste recycling in Dubai is higher than plastic waste recycling. This can lead to the fact that paper is more likely to be recycled than plastic, adding to that the fact that paper is more eco-friendly material (DM, 2021).

Union-Coop Supermarkets

Union-Coop supermarket has 23 branches across Dubai. The special feature that Union-coop supermarket has over other supermarkets, that it has different social and community initiatives. It pays attention to the society and the environment as a whole. Union-coop supermarkets has a vision towards recycling materials. They have made contracts with companies to collect the used cartons in the supermarket for recycling. Furthermore, plastic bags used in Union-Coop are 100% biodegradable. They believe in the concept of Reduce, Reuse, Recycle (Coop, 2021).

Number of plastic bags used in Union-Coop Supermarket

Union-coop supermarket is one of the biggest supermarkets in Dubai. In 2011, there was 10 branches for Union-Coop supermarket in Dubai, nowadays there are 23 branches across the city. Union-Coop supermarket uses around 2400 kg of plastic bags per day (union-coop, 2021). As a standard, there is around 50 plastic bags in 1 kg of plastic bags. A simple calculation will give us the approximate number of plastic bags used daily in Union-Coop supermarket:

Total Number of Plastic Bags = Plastic bags in Kg * Number of plastic bags in 1 kg

Total Number of Plastic Bags = 2400 * 50

Total Number of Plastic Bags = 120,000 plastic bag.

Carbon emissions produced by plastic bags

Plastic bags are a big source of carbon dioxide, from manufacturing, transportation, until disposal. One kilogram of a single use plastic bags produces around 3 kg of carbon dioxide in the planet. This is a huge amount of carbon dioxide looking at the huge production and consumption of plastic bags around the world (Cross, 2019).

Calculating carbon emissions produced by plastic bags used in Union-coop Supermarkets.

Taking the total amount of plastic bags(kg) used in Union-Coop supermarkets in Dubai, which is 2400 kg per day, the total amount of CO₂ produced daily by the bags used in Union-Coop supermarkets will equal to 7200 kg of CO₂. This amount of carbon dioxide is considered high on a daily base especially with the UAE Net Zero vision to limit the emissions that are responsible for climate change (UAE.GP, 2021).

	No. plastic bags/kg	Carbon emissions (CO2)/kg
CO2 produced by 1 kg of plastic bags	1	3
CO2 produced by n number of plastic bags used in Union-Coop Supermarket	2400	7200

Table 2: Carbon emissions produced daily by plastic bags used in Union-coop Supermarket.

RVM as a solution

The proposed solution in this research for the problem of plastic bags is using Reverse Vending Machines (RVM) in the supermarkets of Dubai. These machines will work as plastic collection hub, they will be used for plastic bags only. Every time the consumer inserts plastic bags, he can get points that can be used as a discount in the supermarket. The number of points depends on the weight of the material inserted by the customer. The machines will be distributed initially in one of the biggest supermarkets in which is Union-Coop.

Phase 1

The project will be implemented in 2 phases to see how likely are people to use the machine. In the first phase of the project, 10 machines will be distributed across 10 branches of union-coop supermarket. Data such as number of users of the machine, and the weight of plastic materials inserted every day will be monitored to help in creating a clear picture about the effectiveness and the efficient of the machine.

Phase 2

Through the data gathered from phase1, a decision will be made for whether to integrate more machines in the left 13 branches, or there are some improvements that must be made to increase the efficiency of the machine and make it more attracting for the customers.



Figure 8: Union-Coop branches map as shown in Google maps.

Proposed RVM machine

The proposed RVM will be designed specifically to meet the purpose of the machine, it will have a material inlet window, a button to proceed, and a small outlet for discount coupons. The design must be simple in order to be easy for different categories of people. The dimensions of the machine will be similar to standard big size vending machines, with 2 meters height, 1.2 meters width, and 1 meter depth (Gaitonde, 2019).

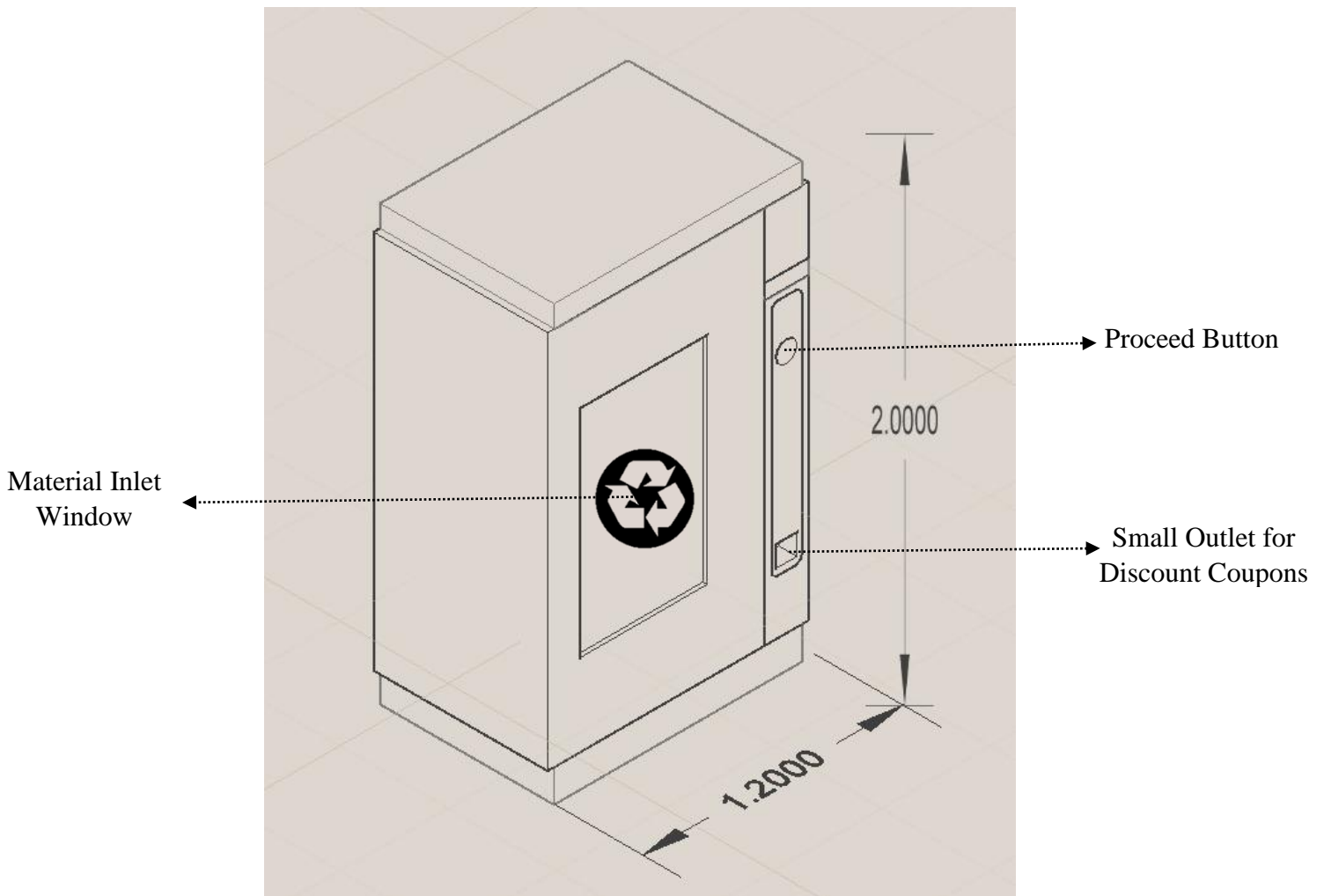

Figure 9: Design of the proposed reverse vending machine (RVM)

Reason behind using RVM machines

A possible reaction towards these machines would be that they are not necessary, and plastic bags can be collected manually at the cashier point. A study made in Thailand about the effect of using RVM in plastic recycling found that when RVM was used, there was a noticeable increase in the quantity of plastic that was collected in the machine (Tiyarattanachai, 2015). This is because VM in general, are easy to be used among young and older people. They are simple, easy, safe, and time saver. Moreover, the RVM concept depends on collecting the material, and scan it in order to classify it before it goes for the recycling centers. This helps in sorting the materials from the early stage before reaching the recycling center, therefore it will save time, effort, and money for the recycling centers.

Moreover, the recycling rate of plastic bags is very low. In the United States, from 102 billion used plastic bags, 92.8 are not recycled. This is because the separation of plastic bags is very hard. When plastic bags are passing through sorting machines, they stuck in the machine causing big plastic jam that destroys the machinery (BEHM, 2019). By specifying a RVM for plastic bags only, this can save time and money in the recycling process.

A study on the behavior of citizens towards using RVM

In Kazakhstan, research was done to study the integration of RVM in the waste system of Kazakhstan. A survey was conducted to highlight the different factors affecting plastic waste, such as education level, type of waste generated by people, the total awareness in the society, and the behavior of people towards using RVM. The study was conducted among different categories of the society. They were classified according to the gender, age, education, and occupation.

How can the study be reflected on Dubai?

The study can be reflected on Dubai as the two regions are sharing the same characteristics such as extended family, strong family bonds, and the middle eastern taste of food. These characteristics are what make the supermarket visit a must in both Dubai, and Kazakhstan (Hays, 2016). Moreover, 6 in 10 people in Dubai prefer to visit the supermarket over online orders (Nair, 2020). They are not fully dependent on online food orders and delivery, which make the implementation of RVM idea successful in both places. Furthermore, both places share the concept of smart city, they focus on the development of the city with maintaining a sustainable vision of development (UN, 2020).

The study found that 29% of the participants are recycling the waste, and people with higher education has a higher recycle rate among others (Amantayeva, 2020). This means that people with low level of education need to be more aware of the problem. A study was done in Malaysian Universities to test the effect of the education on the awareness of environmental issues. It showed that factors such as education, age, and family status affect the awareness of the environmental issues positively. People who are older, married, and educated are more aware of the environmental issues than others (Aminrad, 2011). Awareness must be equal among all categories of the society in order to overcome plastic pollution problem, and other environmental problems. It should start from the young generations because they have the power and the ambition towards drawing a better future.

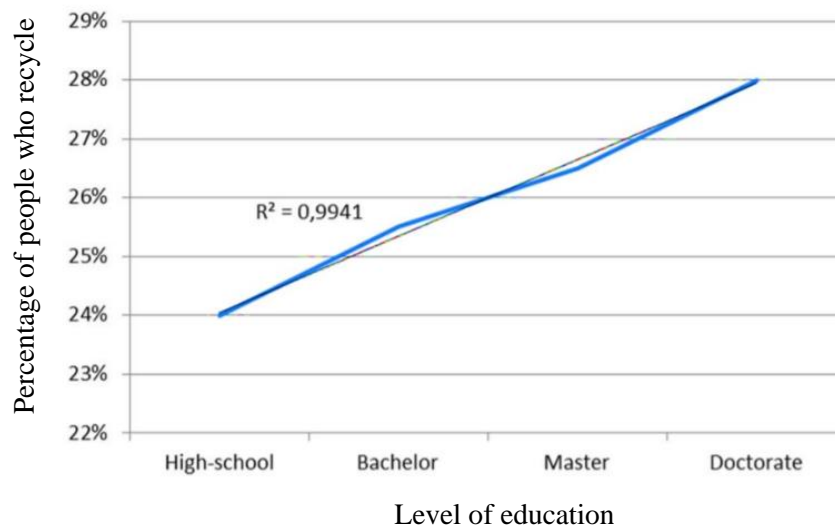

Figure 10: Education level effect on recycling rate (Amantayeva, 2020).

Moreover, the study found that people prefer to get discount rates in the supermarkets rather than having other kind of rewards such as bank card deposit, or free Wi-Fi (Amantayeva, 2020). Customers are more attracted to different discount forms such as vouchers, coupons, points. Some of the customers purchase things that they do not need or plan to purchase, only because it is discounted (ROESLER, 2018). This supports the proposed solution of making the recycling process more attractive by adding discount points. This will encourage people to collect plastic bags wherever they see it. In this way we will achieve different goals such as increasing the recycling of plastic bags, cleaning the environment from plastic bags, and saving money for the customer as a reward of recycling.

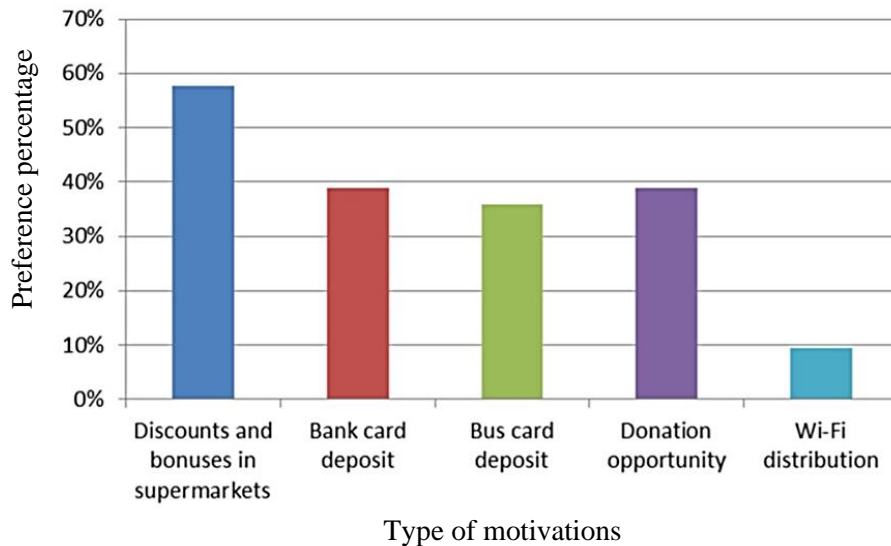

Figure 11: Types of motivations that respondents prefer while using RVM (Amantayeva, 2020).

Chapter 4

4.1 Conclusion

The research found that recycling rate of plastic waste in Dubai is low compared to other materials such as paper waste. This leads to a possible consideration of replacing plastic bags with other materials that are more recyclable such as paper. Moreover, the research found that the amount of plastic used in Union-Coop supermarket only, leaves a considerable carbon footprint in the environment which increases the plastic pollution around us, that eventually leads to the increase in air pollution. This issue must be studied by the supermarkets in Dubai and other emirates in order to limit and control the number of used plastic bags for each customer. Furthermore, the study -with the reliance on secondary data- found that using RVM helps in increasing the quantity of recyclable materials by the customers. In addition, customers prefer to get bonus and discounts to be used in the supermarkets, rather than having other motivations such as free Wi-Fi.

4.2 Recommendations

The wide use of plastic bags must be considered in further studies. Specific data collection is required in order to have a clear picture about how serious is the problem, and how it can be solved. Additionally, more researches and studies are required to help with understanding the customer behavior and how likely would the customer prefer to replace plastic bags with bags from another material.

4.3 Future work

Regarding the implementation of the solution of the integration of RVM in Union-Coop Supermarkets, this project must be completed in different phases to test the community response to it, and to have the opportunity for additional improvements. A big part of solving this problem is by spreading awareness among the society by conducting different lectures about plastic pollution for the public. Moreover, workshops about plastic pollution and plastic bags alternatives, must held in schools to spread the awareness from early stages among the young generations. Furthermore, the government can help encouraging people towards using plastic bags alternatives by specifying a suitable price that satisfies all the categories of the society for reusable bags.

After testing the machine for a certain period of time, the idea can be implemented in other supermarkets such as Carrefour, and Spinneys. This will help in increasing the recycle rate of plastic bags, therefore the overall plastic recycling rate in the UAE will increase.

References

- Amantayeva, A. (2020). A systems engineering study of integration reverse vending machines into the waste management system of Kazakhstan.
- Aminrad, Z. (2011). Influence of Age and Level of Education on Environmental Awareness and Attitude: Case Study on Iranian Students in Malaysian Universities.
- BEHM, J. (2019, July 25). *Pros and Cons of the Plastic Bag Ban Debate*. Retrieved from [www.dumpsters.com: https://www.dumpsters.com/blog/plastic-bag-bans](https://www.dumpsters.com/blog/plastic-bag-bans)
- Coop, U. (2021). *CARING FOR THE ENVIRONMENT*. Retrieved from [corporate.unioncoop.ae: https://corporate.unioncoop.ae/en/union-coop-policies-standards/environmental-safety/](https://corporate.unioncoop.ae/en/union-coop-policies-standards/environmental-safety/)
- Cross, D. T. (2019). Single-use plastics leave a large carbon footprint.
- DM. (2021, Nov). Personal communication through email about plastic waste in Dubai. Dubai, Dubai, UAE.
- DSC. (2021). *DSC: Dubai Population is 3.4 Million and Hosts 4.4 Million Daily*. Retrieved from [www.dsc.gov.ae: https://www.dsc.gov.ae/en-us/DSC-News/Pages/Dubai-Population-is-3.4-Million-and-Hosts-4.4-Million-Daily.aspx](https://www.dsc.gov.ae/en-us/DSC-News/Pages/Dubai-Population-is-3.4-Million-and-Hosts-4.4-Million-Daily.aspx)
- emirates247. (2013). *Dubai says no to plastic: Annual usage is 2.9m bags*. Retrieved from [www.emirates247.com: https://www.emirates247.com/news/emirates/dubai-says-no-to-plastic-annual-usage-is-2-9m-bags-2013-05-11-1.506012](https://www.emirates247.com/news/emirates/dubai-says-no-to-plastic-annual-usage-is-2-9m-bags-2013-05-11-1.506012)
- forbes. (2020, Oct 22). *Pollution, Solving The Problem Of Plastic Bag*. Retrieved from [www.forbes.com: https://www.forbes.com/sites/businessreporter/2020/10/22/solving-the-problem-of-plastic-bag-pollution/?sh=3baffc504c8a](https://www.forbes.com/sites/businessreporter/2020/10/22/solving-the-problem-of-plastic-bag-pollution/?sh=3baffc504c8a)
- G7, O. f. (2018). *Improving Plastics Management: Trends, Policy responses, and the role of international cooperation and trade*. OECD.
- Gaitonde, A. (2019, Nov 17). *Vending Machine design — A State design pattern approach*. Retrieved from [medium.com: https://medium.com/swlh/vending-machine-design-a-state-design-pattern-approach-5b7e1a026cd2](https://medium.com/swlh/vending-machine-design-a-state-design-pattern-approach-5b7e1a026cd2)

- HANEY, H. (2020, DEC 22). *Plastic Is Killing the Camels of Dubai*. Retrieved from plasticoceans.org: <https://plasticoceans.org/plastic-is-killing-the-camels-of-dubai/>
- Hassanien, R. H. (2020). Recycling Waste Plastic Bags as a Replacement for Cement in Production of Building Bricks and Concrete Blocks.
- Hays, J. (2016, April). *FAMILIES IN KAZAKHSTAN*. Retrieved from factsanddetails.com: https://factsanddetails.com/central-asia/Kazakhstan/sub8_4b/entry-4641.html
- Joana C. Prata, A. L. (2019). Solutions and Integrated Strategies for the Control and Mitigation of Plastic and Microplastic Pollution.
- Kolcon, M. (2021). Plastic Prohibition: The Case For A National Single-Use Plastic Ban In The United States.
- Li, N. (2009). Reduce, Reuse, and Replace: A study on solutions to plastic wastes. 10-29.
- Mian, N. (2013). Using Plastic Bags and Its Damaging Impact on Environment and Agriculture. 4-45.
- Nair, D. (2020, August 16). *Six in 10 UAE consumers prefer in-store grocery purchases*. Retrieved from www.thenationalnews.com: <https://www.thenationalnews.com/business/money/six-in-10-uae-consumers-prefer-in-store-grocery-purchases-1.1064325>
- Nannu Mian, M. K. (2013). Using Plastic Bags and Its Damaging Impact on Environment and Agriculture. 4-45.
- Ningwei Li, D. M. (2009). Reduce, Reuse, and Replace: A study on solutions to plastic wastes. 10-29.
- Oji, S. (2020). A Look at Plastic Bags and Alternatives.
- Okunola A Alabi, K. I. (2019). Public and Environmental Health Effects of Plastic Wastes Disposal:A Review. 9-10.
- P. Singh, V. S. (2015). Integrated Plastic Waste Management: Environmental and Improved Health Approaches.

- PARKER, L. (2019, June 7). *The world's plastic pollution crisis explained*. Retrieved from nationalgeographic.com:
<https://www.nationalgeographic.com/environment/article/plastic-pollution>
- PAULSEN, J. (2020, NOV 27). *How data is quantifying the impact of plastic on the environment*. Retrieved from gulfbusiness.com: <https://gulfbusiness.com/how-data-is-quantifying-the-impact-of-plastic-on-the-environment/>
- Phillips, W. (2020). Economic implecations of the ban on single-use plastics in the carebbean. 9-29.
- Prata, J. C. (2019). Solutions and Integrated Strategies for the Control and Mitigation of Plastic and Microplastic Pollution.
- Readfearn, G. (2020, DEC 13). *Deadliest plastics: bags and packaging biggest marine life killers, study finds*. Retrieved from www.theguardian.com:
<https://www.theguardian.com/environment/2020/dec/14/deadliest-plastics-bags-and-packaging-biggest-marine-life-killers-study-finds>
- Ritchie, H. (2018). Plastic Pollution. *Our World in Data*.
- ROESLER, P. (2018). New Study Shows Deals and Promotions Affect Every Part of Shopping Experience.
- Samuel Oji, P. U. (2020). A Look at Plastic Bags and Alternatives.
- Sedaghat, L. (2018, April 4). *7 Things You Didn't Know About Plastic (and Recycling)*. Retrieved from blog.nationalgeographic.org:
<https://blog.nationalgeographic.org/2018/04/04/7-things-you-didnt-know-about-plastic-and-recycling/>
- Singh, P. (2015). Integrated Plastic Waste Management: Environmental and Improved Health Approaches.
- Tiyarattanachai, R. (2015). Reverse Vending Machine and Its Impacts on Quantity and Quality of Recycled PET Bottles in Thailand.

- UAE.GP. (2021). *UAE Net Zero 2050*. Retrieved from u.ae: <https://u.ae/en/information-and-services/environment-and-energy/climate-change/theuaesresponsetoclimatechange>
- UN. (2020, March 19). *Keeping Kazakhstan on the Path to a Green Economy*. Retrieved from [www.unep.org: https://www.unep.org/news-and-stories/story/keeping-kazakhstan-path-green-economy](https://www.unep.org/news-and-stories/story/keeping-kazakhstan-path-green-economy)
- union-coop. (2021, Nov). Personal Communication through email about plastic bags used in the supermarket. Dubai, Dubai, UAE.
- Vanapalli, K. R. (2021). Challenges and strategies for effective plastic waste management during and post COVID-19 pandemic.
- Vasarhelyi, K. (2021). *The Climate Impact of Single Use Plastics*.
- Wdse Zjup, N. J. (2019). Current influence of China's ban on plastic waste imports.
- Willard Phillips, E. T. (2020). Economic implecations of the ban on single-use plastics in the carebbean . 9-29.
- Zjup, W. (2019). Current influence of China's ban on plastic waste imports.