

Rochester Institute of Technology

RIT Digital Institutional Repository

Theses

2009

Data center design & enterprise networking

Christian Mahood

Follow this and additional works at: <https://repository.rit.edu/theses>

Recommended Citation

Mahood, Christian, "Data center design & enterprise networking" (2009). Thesis. Rochester Institute of Technology. Accessed from

This Thesis is brought to you for free and open access by the RIT Libraries. For more information, please contact repository@rit.edu.

Data Center Design & Enterprise Networking

By

Christian Mahood

**Thesis submitted in partial fulfillment of the requirements for the degree of Master of
Science in
Networking & Systems Administration**

Rochester Institute of Technology

**B. Thomas Golisano College
of
Computing and Information Sciences**

February 25th, 2009

Rochester Institute of Technology
B. Thomas Golisano College
of
Computing and Information Sciences
Master of Science in
Networking and Systems Administration

Thesis Approval Form

Student Name: Christian Mahood

Thesis Title: Data Center Design & Enterprise Networking

Thesis Committee

Name

Signature

Date

Luther Troell

Chair

Charlie Border

Committee Member

Sylvia Perez-Hardy

Committee Member

Thesis Reproduction Permission Form

Rochester Institute of Technology

**B. Thomas Golisano College of
Computing and Information Sciences**

**Master of Science in
Networking & Systems Administration**

Data Center Design & Enterprise Networking

I, Christian Mahood, hereby grant permission to the Wallace Library of the Rochester Institute of Technology to reproduce my thesis in whole or in part. Any reproduction must not be for commercial use or profit.

Date: _____ Signature of Author: _____

Abstract:

Today's enterprise networks and data centers have become very complex and have completely integrated themselves into every facet of their represented organization. Organizations require Internet facing services and applications to be available at any part of the day or night. These organizations have realized that with centralized computing and highly available components, their technological presence with customers can be greatly enhanced. The creation of an infrastructure supporting such high availability takes numerous components and resources to function optimally. When an organization makes the decision to design a data center, they utilize resources to provide insight into what components to deploy. Much of this information is based off of recommendations made by third party vendors or limited past experiences. This research provides a course offering as a solution to help provide students with the information to design and comprehend the major components within a modern data center. The information included in the course offering has been compared with industry accepted standards and various other resources to provide reliable and accurate information. Course topics have been architected around eight major topics. These topics covered are network design, electrical systems, HVAC (Heating, Ventilation, and Air Conditioning) systems, security, management, redundancy, disaster recovery and site planning. The information contained within the lectures has been compiled from multiple sources to provide a single location for information. Furthermore, the course offering will utilize class discussions, case study analysis and activities to re-enforce key points. Providing such a course for students to learn about data center components will provide organizations with the ability to rely less on outside information and design scalable data centers that can provide years of growth.

Table of Contents

1 Introduction	1
1.1 Problem	1
1.2 Importance	3
2 Review of current research	3
3 Background	8
4 Research Design and Methodology	10
4.1 Assumptions and Limitations	10
4.2 Research Methodology	12
4.3 Test System Design	14
5 Results	15
5.1 Course Textbook	15
5.2 Topic Design	17
5.3 Topic Expansion	19
5.3.1 Network Design	19
5.3.2 Electrical	22
5.3.3 HVAC Systems	24
5.3.4 Security	27
5.3.5 Disaster Recovery	28
5.3.6 Tools	30
6 Conclusion	31
7 Future Work	32
8.1 Course Syllabus	33
8.2 Course ICC Form	39
8.3 Course Lecture Slides	43
8.3.1 Week 2 Slides	43
8.3.2 Week 3 Slides	52
8.3.3 Week 4 Slides	60
8.3.4 Week 5 Slides	71
8.3.5 Week 7 Slides	80
8.4 Midterm Exam Example Questions	89
8.5 Midterm Exam Example Questions	91
9 References:	93

Table of Figures

Figure 1 12
Figure 2 17
Figure 3 18
Figure 4 30

1 Introduction

Organizational networks have become vast and complex. Many companies throughout the world have data centers that have evolved from single rooms within larger company operation centers into enormous standalone buildings that house thousands upon thousands of servers. There is no longer a notion that a data center belongs only to the large organizations of the world as smaller and smaller businesses are beginning to rely on the centralization and benefits of running a data center that can assist with their overall efficiency. Data centers range in varying size and capabilities today and also are comprised with varying components. There are a number of different pieces within a data center that must mesh together seamlessly for performance to be optimal. In order for an organization to implement and build a data center, heavy planning is involved to understand the needs of the organization and to determine the full scale of the end result. Some organizations may pay particular attention to financial side of the data center, while other organizations may pay attention to overall space that can be achieved. This particular need will vary from organization to organization, however there are multiple key areas that must be addressed to design a functional data center.

This research aims to provide a solution for academic institutions to provide students with a location to learn about data center design and networking. By providing information about data center design and networking, students will be able to utilize experiences and information from the class in future careers for organizations that wish to reconfigure, plan or retrofit environments for usage as a data center.

1.1 Problem

Data centers require a large amount of planning, interaction with different resources and a large understanding of different areas of expertise to implement from start to finish. There is

a large amount of cost and time dedication to understand all types of technology and components that must be implemented within a data center. There is information available across many different platforms (the Internet, books, articles, etc,) however there lacks a resource that can help students understand the components and the importance of design in the planning of a data center. The development of a course offering that covers these topics will allow students to share experiences that they have encountered and also will allow students to collaboratively learn different fundamentals together through discussion.

There is ample data available in libraries, the Internet, various books, and magazine articles that can assist in the planning and implementation of a data center for an organization. Many of these resources are difficult to obtain, contain information on a single piece of the infrastructure, lack comprehensive information in one source and do not provide adequate recommendations based on experiences. The information can be difficult to obtain due to financial investment and also can take long amounts of time to correlate. The large amounts of data make it difficult for a user to decipher exactly what components are critical and vital to the success of the project. It is important to design the data center for current organizational needs, yet plan for the growth of the data center to meet the needs of the organizations for the next ten to twenty years.

A course offering that compounds the information and allows individual student experiences to be shared is one approach to decrease the need for various different external resources. This research has not focused on the benefits to centralization of information in regards of a data center, but presents a solution to assist students comprehend and understand the necessary components within a data center and takes a large step of gathering the information out of the picture. Many sources discuss how to create a data center surrounding current organizational needs. A data center is then designed surrounding these "needs," however within two to three years the organization could realize that it has run out of space and needs to determine their course of action yet again. How could the responsible person then go back to the organization and ask again for hundreds of thousands of dollars

for yet another data center? Thoughtful planning and estimation throughout the design process could have mitigated this by understanding scalability concepts.

1.2 Importance

Planning throughout the entire project of a data center is important as it allows for the correct estimation and scope of the various components supporting the data center. The infrastructure of the data center can allow flexibilities in the system components installed in the data center if planned correctly. The various components from electrical, and heating, ventilation and air conditioning (HVAC) systems installed in a data center are usually modified to provide higher capacities and many organizations could utilize the skills learned in an course offering to provide conscious decisions during projects surrounding their data centers. This research will benefit any organization that is looking to build, retrofit, or modify a data center. It will also benefit any institution looking to implement such a course to assist students in understanding data center design and major components.

2 Review of current research

Research regarding the components of a data center and their importance has been covered in industry and academia led research. There is an importance understood that the data center itself provides many opportunities and unique features that other types of computing do not feature. Highly powered condensed server clusters and high availability hardware make the data center a critical component to today's organizational success. How can these types of environments be planned correctly for full scalability? Furthermore, how do all of these components work together in a fashion that can be managed successfully? In this section, prior research is presented about data center criticality, poor site planning, network components, management and lastly scalability importance.

(Alger, 2005) focused on the need for administrators to realize and fully understand the critical tie of a Data Center to the business it supports. The purpose of his publication was to inform administrators and executives of the planning involved with a Data Center. The other focus of the publication was to address the magnitude of components that go into a Data center and how to choose the best solution for the needs of the business, or customer. His research was qualitative regarding the components and included quantitative methods involving designing analysis. The book was written pulling the experience from the author and those from the Cisco Infrastructure Team to give administrators, professionals and executives a better understanding of a Data Center. The book structures itself into the key areas of the data center; the site, the space, the electrical system, the network, the air and temperature of the site, and the management of the Data Center. The results of the publication are multiple different views and opinions about the design and implementation of the Data Center and the available options to the customer all in a single publication. This publication is unique in that it combines almost all aspects of the data center together in an analysis to the depth that all key points are covered. The technical flaw of this publication was that it does not cover the depth necessary in Data Centers for networking segregation and flow layout.

Another similar publication (Snevely, 2002) discusses thoroughly about the lack of construction planning when approaching a Data Center. The main focus of his research was to provide those interested in planning the construction or re-construction of a Data Center and even as minute as reconfiguring or retrofitting an existing infrastructure wiring closet. His attempt was not to cover the all aspects of the design of a Data Center, but to provide resources to help assist the design of a Data Center based off of the needs and requirements of the Data Center for constructional purposes. His research included qualitative methods of construction and design from previous case studies, experience and documents. The material covered inside the book ranges from exterior space designs down to the wiring inside a Data Center rack and even includes trash control methods. Rob extensively covers and stresses the importance of planning in a Data Center. Each section within the book

covers at least one tip or key point to make note. The book also covers in depth the need to follow local and federal building code in regards to the construction and implementation of components in Data Centers. This is a unique feature that should be taken note during planning stages. The conclusion that Snevely made during his book was that while the planning of Data Center is complicated, if done correctly the Data Center can provide a scalable and modular environment for any size and capability needed by the customer. The other result of the book is a publication that can provide quick reference for design requirements and tips. The difference in this publication in comparison to other works is that while it did not comprehensively cover server components, or network components it did cover the majority of the environmental components necessary to data center design and should be looked at as a valid resource for students.

(Berkowitz, 1999) presented an in-depth analysis of enterprise networking and components of enterprise networks. In particular, this publication focused fully on enterprise networking rather than networking in general. The author recognized a problem with networking “cookbooks” that claim to teach everything, but lack the follow-through of explaining the “what and why” of networking. In this publication, particularly chapters seven and eight, the author distinguished the different layers of the network. It is a unique publication that takes directly into consideration the flow of the network, the performance, and most notable, the implementation of network segmentation. The result of this section was a comparison between the different technologies available and the recognition of cost in the equation during planning and design stages. The author also recognized the vast array of different technologies available to the customer and discusses the need to understand the business’ customer’s needs prior to designing the network portion of the Data Center. This publication directly addressed the need for enterprise network design and went into great detail about this topic. The publication does not address any integration or case studies of Data Center integration and also does not mention other portions of networking in the Data Center other than Layers 2 and Layer 3 of the OSI model commonly referred to in networking. While the

study is useful for a single important component within the data center, it does not present any insight into the integration of any other components relevant to a data center.

A group at Carnegie Mellon University (Sun, 2007) focused on management of Data Centers. They found that monitoring is a crucial component to a Data Center's functionality and maintenance, yet there were not comprehensive solutions to address management. The team at Carnegie Mellon then developed an algorithm that will assist in the management of the Data Center with less of an impact on the administrator. The purpose of this research was to introduce to the arena of monitoring another tool that provided adaptive and reliable results for the Data Center. Their research used mixed methods to take existing knowledge about the SNMP protocol and management software, while new methods were proposed based upon these existing methods. The algorithm was tested on a large cluster at Carnegie Mellon to test functionality and scalability. Their implementation utilized SNMP, which is one of the most ubiquitous protocols available for monitoring purposes. The focus of their algorithm was to assist in and further enhance the configuration portion of monitoring, the reasoning algorithm used to determine if an event is anomalous, and the storage of the historical data. The results of their study included results that were not only positive, but exceeded what they felt were their goals in the project. Their research was relevant to the topic of this thesis in that management and monitoring are crucial aspects to a Data Center.

Al-Fares, Loukissas, and Vahdat (Al-Fares, 2008) discussed thoroughly the need for Scalable interconnectivity in clusters, economic availability, and backwards compatibility with legacy protocols and systems. Their project addressed a concern for connectivity in hierarchical networks where bandwidth is crucial and expensive. The purpose of the project was for the team to introduce the problem to the network community and propose an economic solution that utilized existing equipment to satisfy bandwidth needs. Their solution was a technology called fat-tree, which segregates the network into "Pods" and two-level routing that allows lookups for multi-path routing. The project implemented new code onto existing routers and switches that helped and allowed them to perform the two-level routing and

lookups. The implementation and testing of this technology was successful, however not ideal. The core-switching layer can become congested due to collision and routing decisions made by the routers downstream. The other result that was not optimal was the number of cables required to create a mesh topology for the network. This project visits a unique problem that occurs in Data Centers. The need for scalable bandwidth for interconnectivity is still not as capable as the clusters and technology that is available for usage.

(Sharma, 2008) addressed the importance of cooling, power, and computing in a Data Center with the recent changes to server equipment and design. Sharma, Shih, Bash and Patel describe the changes in server hardware and that it has become more and more dense and powerful over the last decade. This has created a higher level of necessary resources available for these servers to operate successfully and efficiently. To address this issue, the group from Hewlett-Packard proposed a control engine to create a Data Center that can throttle and change its requirements for cooling, power and computing. The authors also discuss how this solution varies from traditional Data Center methodology in that each given area in a Data Center is segmented from others via control engines. The three areas (Power, Cooling, and Computing) can be throttled up or down based off algorithms that the authors have specified. If a higher demand is necessary for one section, others can throttle down to allow resources to be distributed to the other workload areas in the Data Center. They also discussed that the three needed to be managed as an ensemble and not separate entities for benefits to be obtained. The outcome of this project was the realization that energy consumption and flows will continue to be critical in Data Centers and that the management of these commodities will become more and more of a focus during the design of the Data Center.

3 Background

In past implementations, many different groups from different expertise and backgrounds have designed the various components in data centers. Each different group had a niche in their respective field and completed their installation based off of information that was provided to them by the project manager or lead of the project. Server requirements in the past were much different than that of servers and equipment today. The equipment was more bulky, and most systems did not reside in rack cabinets of today's standards. Most systems called mainframes had entire computer rooms built around them requiring high amounts of power and HVAC systems for operation. Their function was to provide highly processor intensive calculations for an organization. They also allowed for high data transfer and multi-client connection as the development of these systems progressed through the years. Some of the most well known of these systems were built and installed by IBM (Mainframe.) The components were not as demanding in comparison to today's data center as computing power was neither highly condensed nor scalable, but the power and HVAC requirements of these mainframes were unique and required special designs for implementation. Computers have advanced considerably since the peak of the mainframe in the 1980's and many systems have been replaced for server systems within the same rooms or data centers that once housed these large mainframes (Mainframe.)

As the demand for the client-server based architecture, the Internet and individual computers has grown exponentially in the past two decades, the need to deploy systems has also increased. While these newer systems do not have the full computing power that comparable mainframes have, their footprint, technological flexibility and lower individual cost creates a large demand thus more and more servers were implemented in short amounts of time (DiMinico.) With further technological advance these servers now can be placed in racks that can house as many as 50 servers per rack. Their footprint condenses the heat output and electrical intake. With this many systems in a single rack, one can clearly see the changes and stress that infrastructures now place on the same environmental support of

these data centers that were originally designed for mainframe usage. Because of these changes, many organizations choose to redesign, rebuilt or start fresh with their data centers.

As environments are re-built, it has become an organization's ability to plan for the scalable future of its infrastructure. From the experience companies have gained from conversion of mainframe to server clusters and implementations, it can be expected that the trend of higher power in a smaller location will continue. This creates unique requirements for electricity and HVAC system, which are the two most critical environmental factors in a data center (Alger.) Planning for these two systems must provide adequate scalability for a ten to fifteen year period in regards to an organizational growth outlook.

In the past data center implementations individuals research components during the project. Components are researched on a need to know basis and solutions are provided by these individuals or by specialized third party contractors. Individuals with the understanding of all facets of the data center are hard to find and can charge high rates to use for consultation. Information for individuals or organizations to complete a project of this nature has typically been dispersed in multiple locations within books, Internet articles and personal experiences. Having this information available is a large tool that can greatly assist in the planning of the data center. Having the information available, in one location and understood by an employee or group of employees within an organization can only assist with the planning and allow for a better project outcome. This is an important piece in a data center project and is a focus of this research.

4 Research Design and Methodology

In this section, an approach to a course offering featuring data center design and enterprise networking is presented. The approach that the research followed was based on the compilation of various information sources to provide coverage of crucial data center components in course presentations. Also presented is the configuration of a test system to show students various tools to utilize for management. Section 4.1 provides assumptions and limitations for the discussed portions of research. The remaining sections 4.2 and 4.3 discuss the approach, and explanation of the research and test system. In section 5, the deliverable results are presented.

4.1 Assumptions and Limitations

This research does not intend to specify that the topics covered by the specified course are the only solution available to organizations or customers. Therefore it is assumed that the research will be applied generally to organizations as a way to ensure that all crucial components are covered and to provide assistance where weaknesses in a specific topic may exist.

It is also assumed that while brand names may be utilized within the material of the course, there are no recommendations implied by this research. The student or organization should decide equipment types based off of internal partnerships and vendors and also which equipment fits their project or environment optimally.

It can also be assumed that by having information in a single location being the course, less time would be spent researching and polling information from different resources. It is also assumed that by utilizing less time performing research to understand topic fundamentals,

the individual can then spend more time learning intricate details and solutions to achieve a better solution for that data center.

Another assumption for this research is that the fundamentals of basic networking technologies will be prior covered. Coverage such as the TCP/IP protocols, basic computer networking, interconnectivity and basic administration responsibilities will not be covered by this research, but will be necessary to understand some topics outlined.

There are vast differences in organizations and customer needs that will not be met by all aspects of this research. Many solutions comprised with components will fit a few customers' needs; however overall not all solutions provide the answer to all data center projects. Crucial components in relation to the data center will be covered, and based off of these components a functional data center can be achieved.

The ideal course offering regarding data center design and networking covers each facet of the data center from the outside brick and mortar to the individual patch cable connecting a server up to a patch panel within a rack. There are many reasons that a course should cover all of these different topics. The first and foremost reason is that within a data center, all components mesh together to create a full solution that is aimed at providing and protecting digital information. Each different part of the data center plays a key role in accomplishing that task. If one component is architected or implemented in a way that does not suit the data center correctly, it could compromise the integrity and reliability of that digital information. Another reason that comprehensive coverage is important is that without the full understanding of how components work, an organization may be unable to create a scalable design that will fit the growth and financial needs if the organization over a period of years. While this research will cover a large amount of information, it will not encompass the full data center project from start to finish as outlined above. The project will follow a set of deliverables that is shown in figure 1 below. These deliverables will be discussed in the results section, but other topics in relation to the course will not be discussed for research

time considerations. These deliverables are specific to the RIT environment and do not outline general deliverables for all course development.

Deliverables
Comprehensive list of course topics
ICC form
Text book choice
List of Case studies
Lecture Slides for ½ of course (5 weeks)

Figure 1

4.2 Research Methodology

To compile information that will serve a good basis for a course offering for data center design and networking, coverage of key components needs to be covered to offer information that students can utilize as a baseline for their understanding. This section will explain the procedures to determine these key areas for the research.

The course will be designed around building upon the core service that it will provide which is data. The network is the first component that should be thought of during the design of the data center. While the physical specifications of the data center are indeed important, without a network design, the remainder of the layout must be made prior to the understanding of the data requirements. The physical considerations, which include the site, the electrical systems, HVAC systems, physical security, fire suppression systems and flooring, should be designed and implemented utilizing specific specialists that understand minute details and specifications of those components. During the course, key points will be re-enforced to provide a level of understanding surrounding these different areas of complex infrastructure determined during the course development.

It can be seen in the paragraph above that there is an immense amount of data to be compiled to fully complete a project of this scale. Section 1 makes the statement that there is a lot of information available regarding these topics, and likewise fulfilling the solution of centralizing those resources for students will be a strong focus of the research.

As there are many different components that are implemented into a datacenter, all topic coverage will be compiled using the same defined methods. Consistency for topic coverage depth will also be utilized to ensure that information is portrayed allowing enough time in the course for adequate coverage. Topic decisions will be based off of the course textbook offerings, and industry standard comparisons. The Telecommunications Industry Association's (TIA) document TIA-942 is an Industry standard for Data center design. Its topics will be reviewed as a source against the textbook for course topics. Each topic will be researched for its background, different types of technology, and implementation into a data center, component hardening for reliability and redundancy and examples of the given component. This information will be compiled from various sources providing acceptable information based on comparisons with other sources, the course text and industry standards. Providing adequate coverage of each topic is crucial, but to extend that coverage to show how the component ties into the full scheme of the data center provides a more realistic approach. The mentioned steps will be utilized for each component and will thus provide equal understanding whether the component is the most critical or adds ease of management to the data center.

To provide a better understanding for the course and for students to reference information outside of the classroom, a course textbook is necessary. Searches online and through library databases will be utilized to look for a solution that provides the best coverage and insight into all of the resources mentioned above. The textbook will be compared to other sources from research and based on the best comparison the book will be chosen. Topics to be concerned with are depth of knowledge portrayed in the source, number of topics covered, relevance to data centers, case study presence or personal insight, and date of coverage.

4.3 Test System Design

To discuss and provide insight of different tools utilized in certain lecture presentations, a set of systems will be created with tools installed for demo. The tools installed onto the demo systems are tools that are commonly utilized by data center administrators to provide ease of duties on a daily basis. Tools assist administrators daily with operations, monitoring, and record keeping of assets, events, and logical data ensuring that reproduction of systems and designs can be completed in the event of loss or disaster. These tools are also commonly utilized to provide record keeping and change management of the numerous systems that are housed within the data center. To provide examples of these tools during lectures, a system comprised of Windows XP and another partition with a distribution of Linux called CentOS 5 will be utilized. These systems will be built on a VMware workstation platform to allow for transparent usage during lectures. A virtual platform allows for software tools to remain installed while changes are made to the system that may jeopardize their functionality. Quick reversion is capable which provides easy fixes to model software during classes.



5 Results

For this research, information was compiled and centralized to provide resources for students to understand data center components, design steps and networking. The information will also allow students to understand common services within the data center environment such as replacing and designing racks to be utilized co-existent with other systems. Students will be able to design networking components from the lowest rack cabinet within the network hierarchy up to the service provider level. To provide adequate understanding of materials covered, a set of deliverables was set forth in the proposal of this project and is provided in figure 1. These deliverables will be discussed within this results section. The course proposed textbook was the first deliverable discussed to provide a location for students to reference material. This deliverable is discussed in section 5.1 and provides the textbook chosen from two reputable sources. A comprehensive topic list was also created to provide a high level overview of what would be covered in this course. This topic list will be covered in section 5.2 and also can be found in Appendix 8.1 under the course topics section. A selection of five lecture presentations is presented to provide content coverage and material expansion in relation to the course objectives and topics. These presentations are covered in section 5.3 and also are shown in their entirety in appendix 8.3. The remainders of the deliverables outlined include half of the midterm and final exam, which is included in appendix 8.4 and 8.5. Also included is the departmental ICC form, which has been completed and provided as appendix 8.2.

5.1 Course Textbook

The course textbook was chosen to be *Build the Best Data Center Facility for your Business* by Douglas Alger. The book by Douglas Alger was compared to *Enterprise Data Center Design and Methodology* written by Rob Snevely. Both of these books cover the majority of Data Center design and networking, but Alger's book covers better in-depth most topics and also

injects personal experience into every chapter of the book. Snevely's book pertains more to the up-front information and does provide a better insight into national building, fire and electrical codes. Information from Rob Snevely's book will be utilized into the lectures and will be provided as an optional reference as the book has been released as a free publication from Sun Corporation (Snevely.)

Another difference between the two books is the usage of diagrams, mathematical calculation formulas and comparisons between technologies. These are all important factors when building and designing a data center. The organization or customer needs to determine the correct materials and sizes that will optimally fit their data center. Differences between products mean cost savings or increases, which ultimately affects the budget of the data center. Instilling the ability to perform the calculations and designs permits faster design times and also allows for verification of bids estimated by third-party contractors. This is an important cost-savings approach to ensure that the solution is geared exactly towards the organizational requirements and goals of the project. It may be found that a solution recommended or put in plans is not adequate for the environment or in opposite cases, is much too large for the environment for the organization's growth scale.

Diagrams utilized in the course textbook allows for students to visualize concepts that are being described within the chapters. A given example would be existent in the description of air handler placement. While reading about the placement of an air handler perpendicular to rows of server racks provides may be an insight a student may not have previously known, it does may not depict a clear understanding. Placing a diagram then represents an example of the air handler and allows different types of learners to understand the same concepts visually. Alger's book utilizes diagrams more effectively for concepts and materials that should be understood. This provides a better platform for students to understand the basic concepts and components for data center design and networking.

5.2 Topic Design

The course topics were designed based off of the course textbook and comparisons with the TIA-942 standard. While there are multiple different topics and components that make up a data center, major sections of the data center will be covered to provide the feasibility to support a basic data center. The topics that are discussed in depth in both the industry standard and the book are shown in figure 2 below. These topics were the most prevalent topics in the two sources and have been reviewed by many in industry. Together these topics provide over 80% of the infrastructure present in a data center. The topics themselves contain sub-topics that allows for a better breakdown of explanation. These sub-topics can be found in appendix 8.1.

Cabling /Networking	HVAC	Electrical	Redundancy
Management	Site Design	Security	Disaster Recovery

Figure 2

With the topics determined, overall course objectives could begin to be set forth. While many of these are generalized, they present the goals that students should be looking towards at the very beginning of the course. At the end of the course, students should be able to fulfill the course objectives outlined in Figure 3 below. These course objectives will aim to assist students in understanding and focusing on key course material of the course. They also served to provide guidance during the research periods of this project to determine what pieces of material were relative to the course development.

Identify and understand different enterprise network fundamentals.
Understand the fundamental processes and procedures of planning, and designing a complex data center and/or enterprise network.
Define resource needs of a data center and network needs.

Describe the different components in an enterprise data center and provide recommendations to others about these components.
Design, plan, manage and implement enterprise data center components.
Compare existing solutions to determine what will fulfill the defined needs of the customer or organization.
Understand hierarchical networks and their importance in scalable and successful data centers and enterprise scenarios.
Write clear documentation that allows better management of implemented solutions.

Figure 3

5.3 Topic Expansion

The topics that were chosen were then developed into course lectures. These lectures are presented in a way that ramps the student's understanding of components from the individual component up to their full integration in a data center. As outlined in section 4, the background of the component is covered of each topic and then the different options of the technology are presented. After the component is discussed as itself, the component is then discussed as its integration to the data center and why it is important to the data center. Ways for the component to be meshed into a high availability or redundancy state are discussed and then security implications in regards to the component. High availability or redundancy is the ability for a given component to remain online, stable, and available when it's other half or another portion of the component has failed or is down for maintenance. This term is commonly used within data centers because of the demand for services to be available 24 hours a day. Many components are thus designed to provide some form of redundancy or high availability. This is a feature that is discussed within each of the topics from Figure 1 above. To finalize each component, examples or diagrams are referenced to show the component in an actual setting. Some components will be discussed with relation to case studies and stories to assist with key points.

5.3.1 Network Design

Covering the different types of networking that occurs within the data center and how to design a network to be utilized in a data center was the focus of this lecture. By far the data network is the most critical component for service offering, transfers between different systems and for storage. While the reasons will be discussed later in this section, the data network provides the ability for servers to perform work and also to provide results, data, and services to end customers and/or other systems. Data centers use networking components similar to other types of networking environments; however the difference lies in the hardware devices that interconnect systems and the way that the network hierarchy is designed. There are also types of networks that are predominantly located in the data

center, which provide unique abilities to other systems. These types of networks are referred to as storage area networks. The remainder of this section will discuss this lecture and its components.

One of the most important topics to be discussed within this lecture is the network hierarchy that is used within the data center. The three tiers that are focused on are the 'edge layer,' the 'distribution layer,' and the 'host or access layer' (Oppenheimer.) These layers provide means to segregate traffic flow and to allow resources to be provided in a high availability mode. Discussed will be the different protocols utilized at the different hierarchies of the design.

The edge layer of the network provides the first layered access from the Internet service provider to the internal network of the data center. This layer is utilized with protocols such as border gateway protocol (BGP) and Enhanced Internal Gateway Protocol (EIGRP) to provide failover tolerance and also to provide the basic service of routing traffic on the Internet among different autonomous systems (Snevely.) The layer also provides the location where the majority of the data center's routers are located. They usually provide aggregation from multiple vendors and could provide a higher link speed to providers.

The distribution layer allows network traffic to be transferred to different sub-networks, customers, and in-house requirements and to provide different types of network resource allocations (Kerr.) The distribution layer is also the primary layer where traffic filtering occurs. This acts as a way to keep certain traffic from polluting the network bandwidth and also helps to limit broadcast and multicast domains. The distribution layer utilizes a mixture of routers and switches to segregate different types of network traffic, while allowing lower branches of the hierarchy different access levels to the Internet or edge layer services. The distribution layer is also considered the gateway layer as different routers communicate within this layer utilizing protocols such as OSPF (Open Shortest Path First) or RIP (Routing Information Protocol) to communicate network information. Hosts within the access layer

utilize gateways in the distribution layer to access resources based on their classification. The lecture covers this layer and denotes different hardware types and diagrams to show how connections could exist.

The host and access layer is the third and lowest layer within the network hierarchy. This layer provides different networking components such as switching, hubs, firewalls, and occasional routers. The primary focus of this layer is to provide the connection from the end device, into the data center network. At the access layer, separate networks may be found that do not connect systems to the distribution layer and edge layer. These networks may provide storage features, and transport from backend systems to systems that connect to the access layer. These network types serve as the remainder of the lecture for that class period.

Storage Area Networks (SAN) and private networks make up the majority of other networks within the access layer of the network hierarchy. SAN networks provide storage solutions over traditional networking mediums. These storage solutions typically are shared storage that can allow multiple systems to access the same storage at the same time. Systems can access these storage collections over traditional hardware (Network Interface Cards, Fiber Cards, Host Bus Adapters), which allows for lower cost implementation and redundancy. This topic will be discussed in a separate lecture in further detail, but the network portion of the technology should be architected in a way that provides multiple (2 or more) connections to the system for redundancy and high availability. Private networks provide data transfers across backend systems to front-end systems without utilizing limited bandwidth. These networks usually are implemented to provide better segmentation and can also be utilized for management purposes (Alger.)

The final portion of this component is to discuss the need for network redundancy. Redundancy within the data network can occur in many different ways. It can occur on the host level with multiple port connections to switches or hubs, or it could be as transparent

as running multiple routers within the edge layer utilizing the HSRP protocol. Although the HSRP (Hot Standby Router Protocol) is a Cisco proprietary protocol, it can be utilized with different hardware vendors and systems and can provide transparent router redundancy within the network. Redundancy increases the overall availability of the network to customers and servers themselves. The overall goal is to continue service in the event one service provider, one cable, or network port fails. There are different requirements for availability of the network in different data center tiers. These tiers will be discussed within depth during the lecture and will provide students with the understanding that whatever data center their organization functions they should be aware of network availability.

5.3.2 Electrical

Electrical infrastructure and configuration is also a crucial component of a data center as it provides the network hardware, servers, HVAC systems, and lights with the necessary energy to function. This lecture focuses on the discerning of different electrical specifications as well as the infrastructure that is necessary to provide a consistent, reliable and scalable electrical infrastructure for the data center. It was chosen as a key topic because of its importance in the overall design of the data center and because it is usually not focused upon by individuals with networking background. The goal of the lecture and this topic is to provide students with the ability to analyze information presented to them about electrical design in the data center and to be able to calculate needs for power requirements. Overall the most critical topic regarding an electrical infrastructure is the redundancy and standby power offering. This is not the only section of electrical infrastructure that is covered; however it is the most crucial to providing high availability within the data center. Similar to redundancy in the data network, electrical redundancy focuses on providing multiple circuitries that can serve systems and devices in the event of a failed circuit, electrical provider or standby system. This becomes an important topic when discussing different types of electrical power. There is a large debate surrounding alternating and direct current electrical power and becomes forefront during the discussion of standby and redundant power. There is a

loss of electrical power between AC and DC power during conversion within uninterruptable power supplies (UPS).

Voltage selection becomes a debate in many data center environments. Many experts believe that direct current is a better solution than that to AC (Rasumussen.) This lecture will cover the differences in both types of electrical power and will outline the benefits and drawbacks to both. The class will ultimately be able to decide which technology is better for the data center. A slide within the lecture shows the comparison of these two technologies and the different financial implications for either technology. Although preference is a factor in the decision process, cost to the organization or individual usually is the winning factor. This section will provide unique discussion and will reflect upon personal implementations from students, and the book.

Another topic covered in this lecture is the ability to forecast and provide adequate electricity for the data center. There are many tools to utilize for this and many tools ranging from government provided tools to individual proprietor tools would be discussed. Many of these tools utilize kilovolt amperage as the metric to determine need, as it allows for an industry standard to develop solutions. The ability for an organization to understand their requirements and forecast needs can attribute to a scalable infrastructure that will provide longevity in returns from purchased equipment. Scalable infrastructure also lowers cost overall by creating means for an organization to add capacities with little overhead costs. An example of scalability covered in the lectures is the addition of circuit panels that leave room for extra circuits to be allocated for rack space, network devices, and HVAC systems. Whips are defined as cabling that is run from circuit panels to the end system for connection to the electrical systems. These whips usually are comprised of a single or dual circuit that does not share its electrical load with other systems. This usually consumes electrical circuits at a fast rate because of dedication to individual systems. The ability to forecast and implement the capability to continue supporting single circuit whips while maintaining healthy electrical

loads constitutes good forecasting from a design standpoint. Examples such as these are covered within the lectures to provide better insight for the importance of scalability.

The last section that is important for electrical systems within a data center is the ability to sustain power in the event of power source failure. There are many different types of solutions that can provide a data center with means of electricity in the event of an extended outage. Some of these solutions propose utilizing battery systems to ensure critical systems remain online during the outage. These systems provide a limited extension of electricity, as battery capacities are generally not as extensive as other solutions. Ensuring that there is at least a thirty-minute window for administrators to provide triage to systems is a good measurement to scope battery implementation. Another solution for backup electricity is for a generator. These generators usually can provide electrical means for a data center to allow system to remain online for hours and even days. Many of the systems utilize typical fossil fuels as diesel, natural gas or gasoline to generate electricity. These systems should have agreements with fuel providers in the area to guarantee provisions in times of outages (TIA-942.)

Many data centers use a combination of the above solutions to provide a fully redundant system that can allow the data center to remain independent of third part electrical providers. Whether the system is battery or generator, it should be scaled large enough to power the entire data center in the event of an outage. This assists to ensure the data center's SLA to customers and income to the organization is not lost due to downtime. These topics will be fully covered within this lecture, and the ability for students to reflect on experiences will add to the discussion of electrical importance.

5.3.3 HVAC Systems

This lecture will discuss the importance of heating, ventilation and air conditioning (HVAC) as it relates to the data center environment. Ensuring that the servers and other equipment of the data center function in a constant temperature with correct amounts of humidity is a

key component. Fluctuations within the environment can cause equipment failures and in certain scenarios cause damage to data. Because this is a topic that is also not covered in depth in many of the other types of classes taken classically by individuals of networking background, this topic was chosen as a focus for a lecture. The goal is to provide students with the capability to make conscious decisions within their design plans and to also have the ability to critically analyze designs proposed by third party providers. The biggest component within the HVAC system of a data center is the cooling components as by nature computers generate heat. Hand in hand with the HVAC system is the way that the data center handles airflow. This is handled with the installation of overhead or under floor air plenums, which provide supply and return air to the HVAC systems. These plenums are the area within the data center where airflow and pressure occurs to provide the airflow necessary to regulate the environment temperature.

In past generations of hardware, temperature control was very important in the operation of the devices. If the device became too warm, stability of the device was compromised (Sharma.) These devices have since been revised and improved to operate in temperatures that are warmer and can allow the systems to remain stable. It has been established in industry that temperatures within the ranges of 64 degrees to 81 degrees Fahrenheit are acceptable temperatures (TIA-942.) This is mainly to provide comfortable temperatures for employees to perform work within the data center and is not limited because of devices.

As mentioned earlier, the most important facet of the HVAC system is the cooling system (Alger.) There are many technologies that have been created to ensure that systems can remain cool. These systems discussed thoroughly in the lecture slides in appendix 8.3.3 will assist students realize that not only are there different technologies available, but that certain technologies will work better in various geographical locations. Different technologies will also offer different levels of redundancy to provide continuous cooling capabilities to the data center. Some systems as will be discussed, provide cooling to the data center that is free and provides months worth of cost free environment temperature

regulation. This presents large cost savings to the organization for utility bills and presents unique decisions to be determined by the designer.

Redundancy within the HVAC system provides the ability to continually provide environment regulation in the event of system maintenance or system failures. Many systems can now utilize the same cooling towers or cooling systems while maintaining several backend systems. This allows for failover while still providing the same level of service to the environment.

As discussed earlier, there are different designs to deliver cooling to the systems within the data center. One of these designs which is under floor plenum with return air above utilizes the fan power of many servers to move air from the ground up to the return ducts in the ceiling. These different approaches to deliver the air are discussed in depth within the lecture slides and provide examples of what can happen if air is not distributed correctly or evenly throughout the data center. To mitigate many of the problems with HVAC systems, the lecture also covers different tools utilized by data centers to locate pockets of mismanaged air and then mitigate the problem by changing airflow designs within the plenum. Thermal design provides the best way for systems to receive cooled air; however the end design depends on the facility that is provided. There are benefits and drawbacks to overhead or under floor design in general, but given the right scenario, both system designs can be beneficial.

5.3.4 Security

Security provides protection to all systems that support and exist within the data center. There are many types of security within the data center ranging from physical security of the premises to personnel safety and access. It was determined that because there is such a vast amount of data surrounding this topic, that it would be a good focus to cover in a lecture about its integration into the data center. The topic was also chosen because it inherently ties back into the infrastructure system of the data, which assists in its management of the data center. The goal of the lecture is provide insight into the crucial systems surrounding security.

Physical security is the most prevalent feature of a data center. In many ways, data centers present themselves as secure locations by ensuring high quality locking mechanisms are in place, high technology access validation systems are put in place and surveillance systems are provided to deter malicious activity around and internally to the data center. Different technologies will be presented as solutions to the students and benefits of those solutions will be outlined.

Heat and water prevention is another key topic defined by security of the data center. Without these two prevention mechanisms, the data center could be vulnerable to fires and flooding. These two hazards present unique challenges to overcome in a data center setting. Typically fire prevention systems are implemented by using water sprinkler systems to douse fires when they are detected. With the large amount of electrical components within the data center, it is difficult to use water, as a loss of data is a large risk. Alternatively, water can present challenges because it could short circuit electrical components under raised flooring without noise, or warning. There are many solutions that are available to prevent both of these hazards. There are many solutions to prevent fires that are presented in the lecture slides in appendix 8.3.4. Inversely systems like a water detection system are available to prevent water damage to flooring systems and electrical components (Alger 207.) To ensure

that these systems are working correctly, continuous sampling must be completed to protect the data center.

The last topic covered within the security lecture will be to discuss personnel safety items. There are many different items within this section that pertain directly to the data center. The biggest of these sections is to provide policy management and enforcement. These two management items provide a structural sense to enforce rule and provide information to others of how the data center functions. This is important for third party providers to understand when they enter the facility and perform services for the data center. If policies are not implemented and enforced, control and regulation of resources is not feasible. These different policy items are included within this lecture and will provide the students with the ability to safeguard the data center and those who work daily within the facility.

Another section to be covered is the adherence to local, state and federal building, fire and electrical codes. These codes are implemented to protect individuals whom work in these facilities and to ensure that devices and infrastructure are installed with materials whose integrity will match stress put on them. This information was compiled from the national fire protection association (NFPA), NFPA 70 (Snevely.) This code is a large reference for those working with data center components and electrical components. The goal of this section is to provide students with resources to locate current codes and regulations as many facets of the data center are still under code development.

5.3.5 Disaster Recovery

The last lecture within the deliverables is a lecture surrounding disaster recovery of the data center. While this topic is one that hopefully organizations never have to utilize, it is imperative that prevention mechanisms be utilized and put in place to defend against data loss. Because this topic is a unique topic in relation to a data center, it was included as a high focus topic to bring awareness to students of its importance in data center operation. The goal of this lecture is to provide students with the ability to design, implement and manage

disaster recovery infrastructures that can be utilized in the event of accidental data loss or disaster.

The primary focus of the lecture is to cover the different solutions pertaining to backup systems in the data center. Solutions such as onsite tape backups and off-site storage solutions will be discussed providing the benefits and drawbacks to both situations. Solutions comprised of removable media other than that of tape systems will also be discussed and how they fit into the data center today. Off-site storage solutions will be discussed in relation to the rotational periods in which media should be stored off-site. Discussions to determine what solutions students have tested will be engaged to promote information sharing.

Another important situation that should be noted within disaster recovery systems is the way for data centers to test and devise test procedures to ensure that the systems implemented work in the ways that are specified. Many systems can be implemented within the data center to prevent disaster from occurring, however if these systems do not function the way that they were devised, they provide the data center with no benefit. To assist with these test procedures, documentation should be stored in secure locations on contacts, emergency personnel contacts and guidelines on how to restore the functionality of the data center in the event of total catastrophe. The lecture covers different facets of the data center should provide procedures and documentation for to ensure that students can then document and provide meaningful prevention to any disaster that could occur within the data center.

5.3.6 Tools

Throughout the course miscellaneous tools will be presented to the students to show the vast capabilities that they can provide for daily administrative functions and the designing of a data center. These tools provide the robust ability to forecast entire data center power requirements to the simplicity of managing IP address reservations and subnet information. An example of some of the tools utilized within the course is shown in Figure 4. The tools will be demoed on a virtual system discussed in section 4.3. The tools that will be shown also are open source tools or freeware and can be distributed to provide future reference. The impact of the tools for the administrator is that they will shorten and simplify management tasks. An example of these tools is the power calculator spreadsheet that is distributed by the government to assist with calculating energy needs. Rather than take inventory of all systems manually, this checklist helps to estimate and forecast future needs. This provides an easier way to obtain quotes from vendors and will cut time to develop solutions within the planning stages of the data center.

Rack Tables	ClockingIt.com
Pass Safe	SharePoint
Nagios	IPPlan
Dell Rack Calculator	Link and Speed Testing Tools

Figure 4

6 Conclusion

Data centers provide huge amounts of revenue for organizations and host vast amounts of data that is critical for organizations to function. Their design and implementation is an important feature for organizations thus this research is important. The problem of providing a course offering for students surrounding data center design and networking can be solved by using solutions presented by this research. Students and organizations that employ students with networking background can benefit from this course offering because it presents information that allows them to design and make decisions based off of their own requirements. Information is placed within easy access and provides personal insight that can be of assistance when confronted with technology or requirements that may not be clear. Further, the research covers the need to understand all facets of the data center. While understanding single systems is an important skill set to have, understanding the integration of multiple components together allows the individual to have better insight of how the data center meshes together to provide services. All facets of the data center must mesh together to provide the working data center. If one system fails, the integrity of the data center is no longer optimal. This is why redundancy is a stressed implementation within the data center. Without the redundancy, services would not be as highly available as many hosted services have become today. Focusing on the redundancy and solid implementation of data networks, electrical infrastructure, HVAC systems, and security will provide the means for an organization or student to design and provide solutions for a customized data center.

7 Future Work

It has become a trend in recent years to utilize virtual components to provide a better scalable infrastructure with better service provisioning. In future research, attention should be focused on the integration of these virtual environments into the data center. If the new environment could support and present virtual redundancy as well as physical redundancy, it then would present an N +1 redundancy that could greatly prevent failures and bolster high availability. Virtual technology may also be able to take advantage of the multiple core processing technologies thus allowing for higher condensation of resources into a single rack location. This will present new scenarios for data center administrators to overcome, as the concentration of resources will require new electrical, HVAC, and network resources. One could assume that virtual technology would lower the strain on data center resources, but the conversion of aging systems to newer concentrated systems may actually increase the requirements on data, electrical and HVAC. Furthermore, it could be useful to determine how primarily network resources will be impacted as these requirements will be easily condensed into systems to provide dedicated links to virtual machines and the clustering of network resources on single resources.

A new type of modular data centers is aiming to provide mobile solutions to fulfill customer needs. These types of data centers incorporate all necessary components of the data center into one location to provide vendors with the ability of building a data center in a container and then shipping that container to a location that provides modular connectivity. This topic could be utilized in future experiments to determine the types of infrastructure required to implement such a design and to also the implication it would have on the topics specified by this research (Hamilton.)

8 Appendices

8.1 Course Syllabus

Course Syllabus
4055-883
Enterprise Networking
200 Course Syllabus

REMINDER: The information presented in this syllabus is subject to expansion, change, or modification during the quarter

Instructor: Name Office: Bldg. 70-  email address:	Office Hours: M: Or by appointment. <p style="text-align: right;">http://mycourses.rit.edu</p>
---	--

Course Text and Materials

Required Text book:

Douglas Alger, *Build the Best Data Center Facility for your Business*. Cisco Press, 2005. – ISBN:1-58705-182-6

Optional Materials:

Rob Snevely, *Enterprise Data Center Design and Methodology*. Sun Press, 2002 – ISBN:0-13-047393-6

Important RIT Deadlines

Last day of add/drop is March 16th.

Last day to withdraw with a grade of “W” is May 1st – The deadline for withdrawing from a course with a W grade is the end of the 8th week of the quarter. Forms may be obtained from your department office and need your instructor’s signature.

NOTE: The department policy states that a student has one quarter to **challenge** any **grade**. After that, grades cannot be challenged.

Course Description

This course will provide students with the knowledge and understanding to apply design

techniques and logical segmentation to large-scale enterprise networks. Theoretical concepts of large-scale networks will be discussed and students will create designs based on this theory. Case studies will be utilized to help understand different components and their importance in the overall scheme. This course will provide students with the knowledge needed to apply available tools for modeling network functionality to determine the impact of network infrastructure modification, device reconfiguration, and the impact of new application rollouts. Design/case study project required.

Course Objectives

General

At the end of this course, students will be able to effectively **use** and **implement** tools needed for the management, design and creation of enterprise scale networks and datacenters. Students will develop procedures to ensure that the integrity of the network is usable at the required levels.

Specifically:

1. Identify and understand different enterprise network fundamentals
2. Understand the fundamental processes and procedures of planning, and designing a complex data center and/or enterprise network.
3. Define resource needs of a data center and network needs.
4. Describe the different components in an enterprise data center and provide recommendations to others about these components.
5. Design, plan, manage and implement enterprise data center components.
6. Compare existing solutions to determine what will fulfill the defined needs of the customer or organization.
7. Understand hierarchical networks and their importance in scalable and successful data centers and enterprise scenarios.
8. Write clear documentation that allows better management of implemented solutions.

Course Organization

MyCourses

The course is organized by using RIT's myCourses platform. You are required to have a DCE account to access myCourses at *mycourses.rit.edu*. The myCourses is not only used by faculty to organize, create and manage the course activities and course materials, but also by students to communicate with peers and instructors, access the course content, assignments, course grades, group discussion and feedback. myCourses drop boxes are used for the submissions of homework, projects and exams. The instructor will NOT make use of the FirstClass mail and conferencing system.

Please check mycourses' announcement area at least twice a week.

Course Communication

Course communication relies heavily on the content area and the discussion area of myCourses. Course syllabus, outline, lectures, assignments and exams will be posted at the content area. The weekly discussion topics will be posted in the discussion area. Students are highly encouraged to participate in the discussions by posting your comments and/or questions related to that week's material to that area.

The in class lectures are scheduled on Monday between 6:00 PM-7:50 PM for students who enroll in 4055-883-39. These in class lectures will be recorded during class and posted in MyCourses content-area. However, I strongly encourage students from section 90 to attend these lectures either on site or remotely via connect.rit.edu during the lecture time for live interaction. The URL for attending the *Connect* conferences will be posted every week in MyCourses prior to the lectures. The course may also utilize a **teleconference** using Adobe Connect's premiere global services especially for the online students. The exact time of the phone conferences along with the instructions for dialing in will be determined and announced when the class progresses.

Written Exams

The online written exams will include multiple-choice questions, short answers, case study analysis and other content format as appropriate. The exams are designed to be open book, open notes and open references. Students are required to finish their exams independently and in the time frame given.

Individual Homework and Assignments

The instructor throughout the quarter will assign individual homework and labs. These assignments are to be completed independently unless noted differently by the assignment.

Group Projects / Presentations

Students may be assigned to groups to work on the group project assignments throughout the quarter. The group may meet and discuss problems/issues using the *discussion area* and/or *chat function* of MyCourses. Students are required to present their group reports live through the classroom or through connect.rit.edu. Each member of the group is required to participate in the group events actively. Peer evaluations will be administered throughout the projects. If there is a problem that appears on the group evaluations where a member is not cooperating or doing their fair share, then that person's grade on that portion of the project will be subject to reduction at the discretion of your instructor. So make sure that you are involved and in contact with your other group members.

Course Topics

1. Principles of Enterprise Networks and Data centers
2. Networking Design
 - 2.1 Cabling design and types
 - 2.2 Network Hierarchy
 - 2.2.1 Edge
 - 2.2.2 Distribution

- 2.2.3 Host/Access
- 2.3 Network redundancy and fault tolerance
- 2.4 Storage Area Networks
- 2.5 High Availability
 - 2.5.1 Time systems
 - 2.5.2 EIGRP
 - 2.5.3 IGP
 - 2.5.4 BGP
- 3. Physical Design Considerations
 - 3.1 Power
 - 3.1.1 220v/120v
 - 3.1.2 Electrical Segmentation
 - 3.2 Cooling
 - 3.2.1 HVAC systems
 - 3.3 Flooring
 - 3.3.1 Raised
 - 3.3.2 Ground
 - 3.3.3 Weight Factors
 - 3.4 Air/Thermal Design
 - 3.4.2 Hot/Cold Design
 - 3.4.3 Hot/Hot Design
 - 3.4.4 Air Sampling
- 4. Disaster Planning / Recovery
 - 4.1 Backup systems
 - 4.1.1 Onsite storage
 - 4.1.1.1 Tape and Disk Backup systems
 - 4.1.1.2 Removable media
 - 4.1.2 Offsite storage
 - 4.1.2.1 Long-term storage solutions
 - 4.1.3 Test procedures
 - 4.1.3.1 Policy development
 - 4.1.4 Redundancy
 - 4.1.4.1 Electrical
 - 4.1.4.2 Data
 - 4.1.4.2.1 Multiple ISP
 - 4.1.4.2.2 Protocols (BGP, eBGP)
 - 4.1.4.3 Storage
 - 4.1.4.3.1 Storage Area Networks
- 5. Security
 - 5.1 Physical Security
 - 5.1.1 Surveillance
 - 5.1.2 Safeguard systems
 - 5.1.3 Access control systems
 - 5.2 Heat/Water Prevention
 - 5.2.1 Fire Suppression
 - 5.2.2 HVAC/Air Quality control
 - 5.3.3 Water/Moisture prevention
 - 5.3 Personnel Safety
 - 5.3.1 Policy management & enforcement
 - 5.3.2 Fire codes
 - 5.3.3 Building codes
 - 5.3.4 Access control management
- 6. Management
 - 6.1 Remote Management

- 6.1.1 Nagios or Network Monitoring
- 6.1.2 Microsoft Operations Manager/System Center Operations Manager
- 6.1.3 SMS and E-mail Alerting
- 6.2 Onsite Management
 - 6.2.1 Organizational Tools
 - 6.2.1.1 Rack Tables
 - 6.2.1.2 IP Plan / Spreadsheets
 - 6.2.2 Server and environment monitoring
 - 6.2.2.1 Service health monitors
- 6.3 Scalability
 - 6.3.1 Growth capacity planning
 - 6.3.2 Cost Recovery modeling
- 7. Future Technologies

Grading

The grading scale used along with the grading criteria is as follows:

Component	Weight
Discussions	10
Final Exam	25
Midterm exam	25
Final Presentation	25
Assignments	15

Range	Grade
$\geq 90.0\%$	A
$\geq 80.0\% \ \& \ < 90\%$	B
$\geq 70.0\% \ \& \ < 80.0\%$	C
$\geq 60.0\% \ \& \ < 70.0\%$	D
$< 60.0\%$	F

Tentative Course Schedule

Week	Topics/Exams	Assigned Reading	Activities
1-2	Introduction to Data Centers and Enterprise Networks <ul style="list-style-type: none"> - Network Design - Segmentation - Capacity Planning 	Text book: Chapter 1,2 & 7 Lecture notes and online material/articles	MyCourses: Introduction Assignment 1 (Week 2)
3	Physical Design Considerations <ul style="list-style-type: none"> - Site planning 	Text book: Chapter 3,4 Notes, Tools, Slides	MyCourses Discussion #1
4	Physical Design Considerations <ul style="list-style-type: none"> - Components 	Text book: Chapters 5 & 6	MyCourses Discussion #2
5	Security <ul style="list-style-type: none"> - Physical & Environmental 	Text book: Chapter 13,14 Notes, Tools, Slides	Assignment 1 Due Midterm Exam

6	Security/Disaster Recovery - Personnel - Onsite Systems	Notes, Tools, Slides	Assignment 2 MyCourses: Discussion #3
7	Disaster Recovery - Proactive vs. Reactive	Text book: Chapter 8, 9 Slides and online	MyCourses: Discussion #4
8	Management - Remote and Onsite Management	Textbook: Chapters 10,11, 15	MyCourses: Discussion #5
9	Management / Future Technologies	Online Articles	Assignment 2 Due (end of week 9)
10	Student Topics -Presentations	Text book: Chapter 12	Review for final Exam
11	Final Exam		

Cheating Policy: Please review the departmental policy on cheating as described at <http://www.it.rit.edu/policies/dishonesty.html>

Student Responsibilities: Please review the general student responsibilities as outlined at <http://www.nssa.rit.edu/~netsyslab/Responsibilities.htm>

8.2 Course ICC Form



B. Thomas Golisano College of Computing and Information Sciences

Department of Networking, Security, and System Administration

REVISED COURSE: **4055-883**

1.0 Title: Enterprise Networking
Date: 2/25/2009
Credit Hours: 4
Prerequisite(s): N/A
Co-requisite(s): N/A
Course proposed by: Chris Mahood

2.0 Course information:

	Contact hours	Maximum students/section
Classroom	2	12
Lab		
Active Learning/Active Learning Extended		
Other (specify DL)	Online delivery	12

Quarter(s) offered

Fall **X** **Winter** **X** **Spring** **X** **Summer**

Students required to offer this course:

None

Students who might elect to take the course:

Matriculated students in the M.S. in Networking, Security & Systems Administration.

3.0 Goals of the course:

Today's large organizations heavily rely on data services, high availability, reliability and scalability to deliver products and services to their customers. As the online audience continues to grow, more of these organizations are realizing that they must convert existing offerings into digital and online services to enhance their profits and exposure. The challenge many of these organizations face is that they either do not have an existing infrastructure that can host the services necessary, or their existing infrastructures can not accommodate the growth in technology. In the past, many organizations retrofitted rooms within their existing infrastructures to accommodate servers and network equipment. These rooms were usually

small and held a few computers or servers. These challenges have been met by enterprise data centers that are wholly owned, built and designed by organizations, or met by enterprise data centers that are owned by third party companies whom rent space to other organizations. Data centers present a unique difference in the way that resources or networks are traditionally allocated.

This course will explore the numerous facets of a data center along with the important design steps necessary to provide a smooth and reliable operation. At the end of this course, students will be able to describe multiple different technologies used within a data center and will also be capable of designing hierarchical networks that can interact with multiple systems. This course will consist of a combination of lectures, discussions, case study analysis, and a field trip to a dynamic collocation datacenter.

4.0 Course description:

This course will provide students with the knowledge and understanding to apply design techniques and logical segmentation to large-scale enterprise networks and data centers. Theoretical concepts of large-scale networks will be discussed and students will create designs based on this theory. Case studies will be utilized to help understand different components and their importance in the overall scheme of a data center and enterprise network. This course will provide students with the knowledge needed to apply available tools for designing an effective enterprise network that may be implemented in a data center. The course will also present different technologies available currently for usage in a datacenter as well as some emerging technologies aimed towards the enterprise. Design/case study project required.

Class 4, Credit 4

5.0 Possible resources (texts, references, computer packages, etc.)

- 5.1** Douglas, Alger. *Build the Best Data Center Facility for your Business*. Cisco Press, 2005. ISBN: 1-58705-182-6.
- 5.2** Snevely, Rob. *Enterprise Data Center Design and Methodology*. Sun Microsystems Press, 2002. ISBN: 0-13-047393-6.

6.0 Topics (outline)

- 6.1 Principles of Enterprise Networks and Data centers
- 6.2 Networking Design
 - 6.2.1 Cabling design and types
 - 6.2.2 Network Hierarchy
 - 6.2.3 Network redundancy and fault tolerance
 - 6.2.4 Storage Area Networks
 - 6.2.5 High Availability
- 6.3 Physical Design Considerations
 - 6.3.1 Power
 - 6.3.2 Cooling
 - 6.3.3 Flooring

- 6.3.4 Air/Thermal Design
- 6.4 Disaster Planning / Recovery
 - 6.4.1 Backup systems
- 6.5 Security
 - 6.5.1 Physical Security
 - 6.5.2 Heat/Water Prevention
 - 6.5.3 Personnel Safety
- 6.6 Management
 - 6.6.1 Remote Management
 - 6.6.2 Onsite Management
 - 6.6.3 Scalability
- 6.7 Future & Emerging Technologies

7.0 Intended learning outcomes and associated assessment methods of those outcomes

- 7.1 Identify and understand different enterprise network fundamentals
- 7.2 Understand the fundamental processes and procedures of planning, and designing a complex data center and/or enterprise network.
- 7.3 Define resource needs of a data center and network needs.
- 7.4 Describe the different components in an enterprise data center and provide recommendations to others about these components.
- 7.5 Compare existing solutions to determine what will fulfill the defined needs of the customer or organization.
- 7.6 Fully understand hierarchical networks and their importance in scalable and successful data centers or enterprise scenarios.

8.0 Program outcomes supported by this course

- 8.1 Program Objective 1: Design, deploy, and manage data center environments to meet the goals of an organization or customer.
- 8.2 Program Objective 2: Communicate and document clear information that can be used throughout an enterprise organization.

9.0 Other relevant information

None

10.0 Supplemental information

None

Approvals:

Date

Date

8.3 Course Lecture Slides

8.3.1 Week 2 Slides

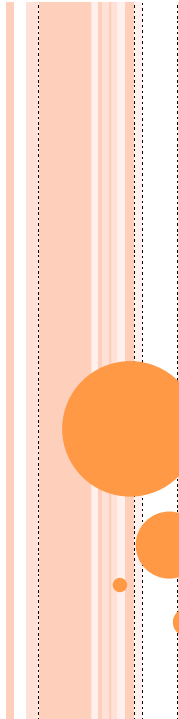

4055-883-39 &
4055-883-90
ENTERPRISE NETWORKING

Week 2
Networking Design

TODAY'S AGENDA

- Importance
 - Network types
 - Cabling design
 - Network Hierarchy
 - Edge
 - Distribution
 - Host / Access
 - Network Redundancy and fault tolerance
 - Storage Area Networks
 - High Availability
 - WAN/LAN high availability
 - Protocols
- 

IMPORTANCE OF THE NETWORK

- Melds everything together from topmost layer down to the individual server
- Provides integral connections to system over different media
- *Can* provide easy scalability for growth.



TYPES OF ENTERPRISE NETWORKS

- Data Networks
 - LAN
 - WAN
- Storage Networks
- System Area Networks (SAN)
- Management Network

- Direct Connection
- Distributed Connection

CABLING DESIGN

○ Types:

- Copper
 - Cat 5
 - Cat 5e
 - Cat 6
 - Cat 7
- Fiber
 - Single-mode
 - Multi-mode

COPPER

- Cat 5
- Developed in 1991 under the TIA/EIA-568-A standard.
- Consists of 4 colored pairs of copper cabling
- Twisted at a rate of 50-65 twists per meter.
- Cat5e was developed under the TIA/EIA-568-B released in 2001.
- Largest difference between Cat5 and 5e is the operating frequency change to 350Mhz.
- Cat5e has introduced tighter specifications



COPPER

- Cat 6
- Defined in early 2008 by ANSI/TIA/EIA-568-B.2-10
- Higher twists per meter than Cat5e allowing for faster data transfer rates.
- Individually separated pairs by plastic divider to decrease cross-talk.
- Transfer rates of up to 10Gbps



COPPER

- Cat 7
- Individually shielded cable pairs.
- Shielded again over all 4 pairs.
- Separated by plastic divider to decrease cross-talk.
- Slated to allow for up to 10Gbps transmission rates.
- No official standard for this cable type yet.



COMPARISON

Cat 7

	Category 5e Class D	Category 6 Class E	Category 6A Class E _A	Class F	Class F _A
Frequency Range (MHz)	1 - 100	1 - 250	1 - 500	1 - 600	1 - 1,000
Insertion Loss (dB)	24.0	21.3 (21.7)	20.9	20.8	20.3
NEXT Loss (dB)	30.1	39.9	39.9	62.9	65.0
PSNEXT Loss (dB)	27.1	37.1	37.1	59.9	62.0
ACR (dB)	6.1	18.6	18.6	42.1	46.1
PSACR (dB)	3.1	15.8	15.8	39.1	41.7
ACR ₅₀ ⁽¹⁾ (dB)	17.4	23.3	23.3 (25.5)	44.4	47.4
PSACR ₅₀ ⁽²⁾ (dB)	14.4	20.3	20.3 (22.5)	41.4	44.4
Return Loss (dB)	10.0	12.0	12.0	12.0	12.0
PSANEXT Loss (dB)	n/s	n/s	60.0	n/s	67.0
PSAACRF (dB)	n/s	n/s	37.0	n/s	52.0
TCL (dB)	n/s	n/s	20.3	20.3	20.3
ELTCTL (dB)	n/s	n/s	0.5 (0) ⁽³⁾	0	0
Propagation Delay (ns)	548	548	548	548	548
Delay Skew (ns)	50	50	50	30	30

COPPER TERMINATION

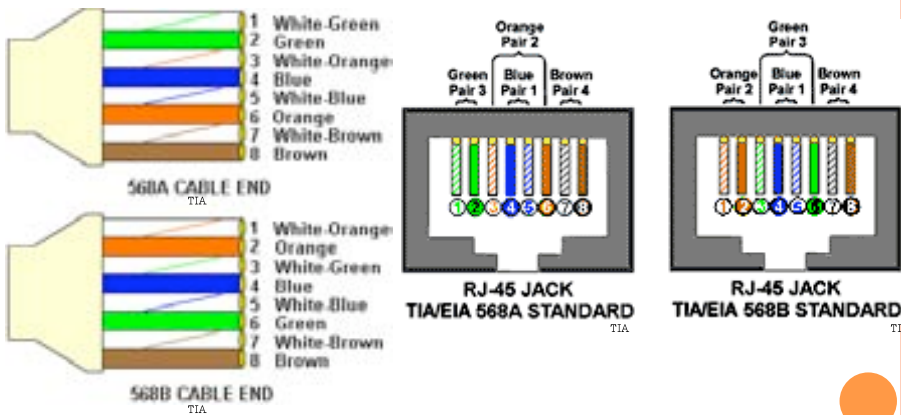

FIBER

o Single mode

- Typically 8-10 μm diameter core surrounded by a 125 μm cladding
- Used for long distances for its high bandwidth and reliability

o Multimode

- Two types exist: 50 μm /125 μm or 62.5 μm /125 μm
- Typically used for shorter distance within a single location for backbone applications or SAN connections.

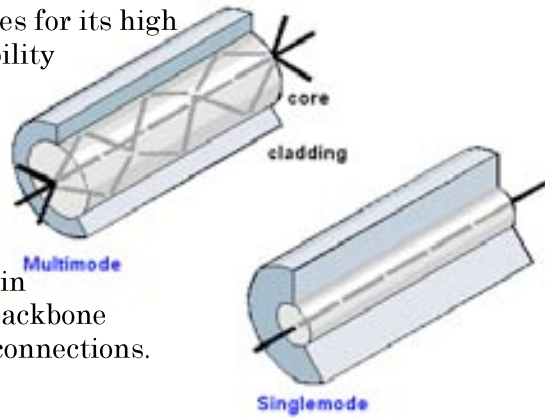

NETWORK HIERARCHY

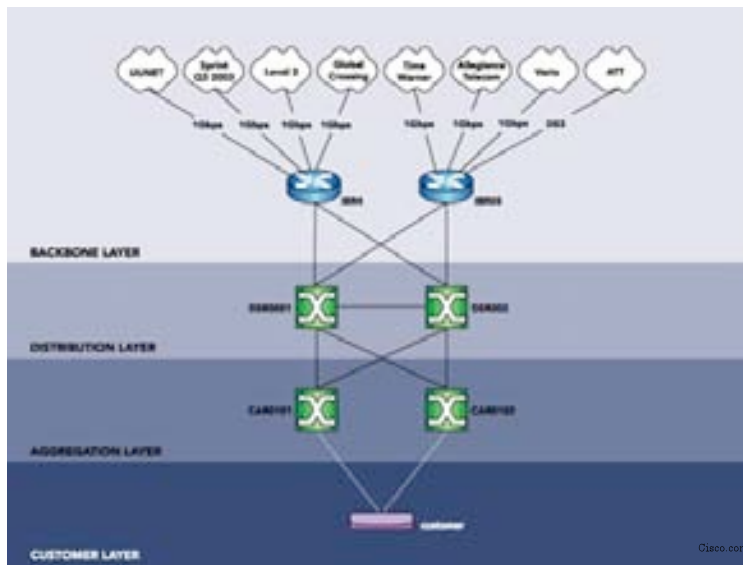

NETWORK HIERARCHY

o Edge/Backbone

- The location outermost to the Internet or Service Providers.
- Contains robust networking equipment that can handle high traffic speeds and can provide high availability and failover through multiple ISPs (Internet Service Providers)
- Protocols such as BGP, EIGRP and OSPF are utilized to provide high availability and failover between multiple ISPs.
- Equipment is primarily routers.
- Routing is not completed for the LAN at this layer.

DISTRIBUTION

- o This layer gathers connections from the Aggregation or Host/Access layers and consolidates them to the backbone or edge layer.
- o Routing protocols at this layer are usually OSPF, IGRP, or RIP.
- o Devices are typically routers and layer 3 switching.
- o Within the data center, this layer is used to breakout access to customers or different groups within an organization
- o Provides QoS, Filtering, and acts as a boundary for broadcast and multicast domains.

ACCESS/HOST

- This is the lowest level of the network where Servers and end devices connect to the network.
- This layer predominantly consists of switches, however routers, hubs, and bridges are often found at this layer
- Devices connect to the switches which then aggregate the data upstream to the distribution layer.

NETWORK REDUNDANCY

- Extremely important in providing high availability
- Can be achieved at all levels of network hierarchy
- Can be achieved by multiple connections to single devices, or could be achieved by multiple devices.
- Active/Active
- Active/Passive
- HSRP/VRRP
- BGP [RFC-4271](#)

HIGH AVAILABILITY

- Types of services require high availability to the end customer
 - SQL Servers
 - Clusters
 - E-Commerce
 - Business Applications
- Small networks provide a backbone (heartbeat network) for these services to utilize and provide redundancy and status information between their systems
- Active/Active
- Active/Passive

SAN (STORAGE AREA NETWORKS)

- This type of network connects multiple different types of devices and systems to shared storage systems to provide a reliable infrastructure.

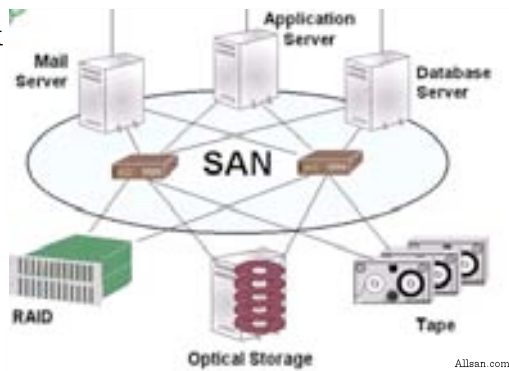

- Fibre Channel
- HBAs (Host Bus Adapters)

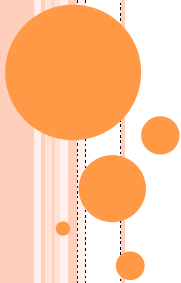

**4055-883-39 &
4055-883-90
ENTERPRISE NETWORKING**

**Week 3
Physical Design Considerations**

TODAY'S AGENDA

- **Power**
 - AC/DC
 - 220v/120v/48v/400v/240v...
 - Electrical Segmentation
 - Redundancy
 - Standby
- **Flooring**
 - Raised
 - Ground



AC – ALTERNATING CURRENT

- In the US, this is the most prevalent electrical current type.
- Used in +90% homes and businesses
- Given its name for changing direction +/- of current flow
- Typically 120v/60hz or 220v/50hz in the US.
- 50hz or 60hz (frequency) is number of times that that wave cycles in 1 second.

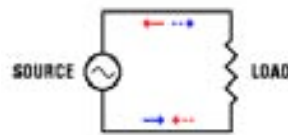

AC



-AC shown in a sine waveform
changing from + to - every
frequency



-AC shown in a triangular form.
AC changes between + and -
every frequency



DC – DIRECT CURRENT



- Provides electricity of one voltage or polarity
+ or –
- Very common in electronic circuits.
- Types of uses:
 - Batteries
 - Telephone Industry
 - Solar Panels
- Common in low voltage devices
- Efficient power in electronic devices

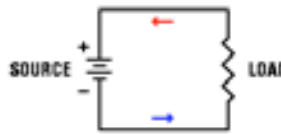

COMPARISON

- AC or DC in a Datacenter?
- AC – Low initial cost
 - Majority of all devices support AC
 - Infrastructure currently built for AC
- DC – Higher initial cost
 - Fewer current devices support DC
 - Devices last longer because of less conversion
- Winner?

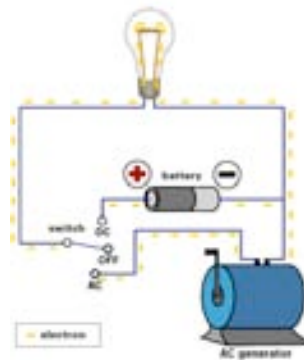

DETERMINING POWER NEEDS

- Many tools exist for this need, proprietary and general:
 - <http://dcpro.ppc.com/DCProDefault.aspx> - DoE
 - <http://hightech.lbl.gov/dc-assessment-tools.html> - Assessment tools for energy and air
 - <http://www.dell.com/calc> - Dell Server and Infrastructure Energy calculator
 - HP Power Calculator –Excel in MyCourses
- Voltage x amperage / 1000 = kilovolt amps
 $(V \times A)/1000 = kva$
- Kva is a standard term used by electrical providers and power assessment tools.

ELECTRICAL SEGMENTATION

- Independent of electrical type chosen, electrical segmentation and design are key elements to provide reliable service to end devices.
- Separate power requirements for items other than servers onto completely separate power systems and sources.

DESIGN

- Similar to the Data Network, design electrical to be Direct-Connect or Distributed (pg139-141.)
- Usage of flexible cables that have free motion of flexibility for cabinet installation
- Plan for different implementations on either end of the electrical wiring.
- Separate breakers per conduit/whip to avoid overloading and to allow better flexibility
- Design a system that is managed or integrates with a building management system
- Provide convenience outlets for various systems and vendors.

REDUNDANCY

- Power redundancy provides a higher level of reliability in the event a single circuit, UPS, PDU, or source main experiences an issue
- Ensure that power strips, UPS devices, or PDUs are no more than 50% utilized
- Redundancy allows for uptime while parts are replaced and/or repaired.

STANDBY

- Provides short-term capabilities of maintaining normal business function in the event of a total power outage.
- Multiple solutions exist from single server UPS systems to full site generator systems.
- This is *NOT* an item to underestimate. Standby systems provide a level of comfort and reliability that many data centers lack.
- Determine that your standby system should provide up to 10% over the data center's maximum power draw.

FLOORING SYSTEMS

- Basically 2 types of floors
- Raised
 - System of steel, PVC, concrete, rubber, aluminum and wood.
- Ground
 - Used typically in an ceiling or overhead installed environment

RAISED FLOOR

- Provides an under floor airspace or plenum for HVAC systems.
- Provides a location for electrical and data cabling that assists to keep the data center looking clean.
- Provides a static reducing element to provide some protection to electrical components.
- Gives more flexibility to the type of methods deployed for wiring termination.
- Tiles within the floor system are 2ft/sq.
- Requires a ramp and occupies additional space within the building

RAISED FLOOR CONCERNS

- To provide static prevention, floor tiles should be grounded.
- Care should be taken when removing tiles to ensure that cabinets surrounding tiles are stable.
- Has a limited number of pounds that systems can ultimately support.
- Area under floor is generally used as an air plenum; care should be taken to ensure cabling is rated for this type of environment (fire and building code)
- Ensure sub-floor is sealed for water and air protection

RAISED FLOOR

3 Types of panels exist:

-Solid Panel (seen at right)

-Perforated Panel (used to direct air above flooring for draw by server cabinet)

- Notched (allows cables and conduits to cross the barrier from sub-floor to main level)

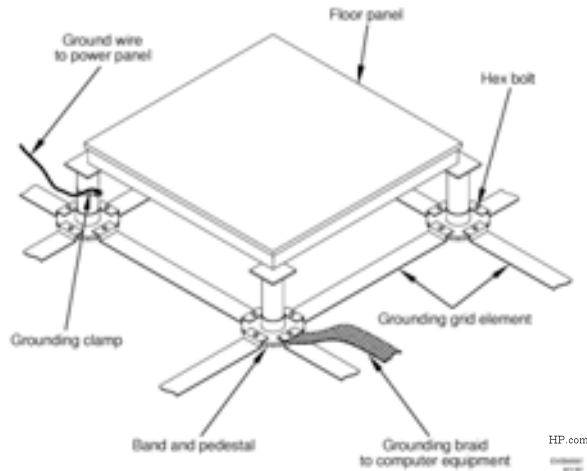

FLAT FLOOR

- Should be used in an environment where more than 18" of under floor space is not possible.
- Structural components are installed above the rack to provide electrical, data and HVAC.
- Separate conduit should be used to provide optimal data transmission and electrical quality.

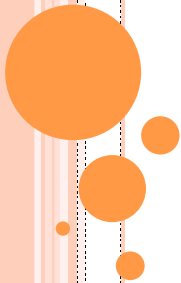

**4055-883-39 &
4055-883-90**
ENTERPRISE NETWORKING
Week 4 – HVAC/Thermal Design

TODAY'S AGENDA

- **HVAC systems**
 - Heating
 - Cooling
 - Humidity Control

- **Air/Thermal Design**
 - Hot/Cold Design
 - Overhead or under floor design
 - Tools



HVAC OVERVIEW

- HVAC (Heating, Ventilation, and Air Conditioning)
- Utilized to maintain a constant environment for optimal infrastructure operation.
- Ventilation is used to allow human interaction within the datacenter
- Cooling is the major component used because of the heat created by systems.
- HVAC systems assist to keep pockets of warm air from creating within the server room.
- System should be monitored and integrated into building system.
- Temperature should be maintained within 64.4 to 80.6 degrees Fahrenheit based on industry standards.

HEATING

- This system is typically handled by the servers themselves. Heat dissipated from the heat sinks and components of the servers warm the environment to a level that is usually too hot for server operation.
- Heating supplement should be used only in areas surrounding the main server location to provide a comfortable environment for employees within the datacenter.
- In locations where humidity is an issue, reheat systems are utilized to add amounts of heat to chilled air to control the humidity levels.

VENTILATION

- Ventilation is important in providing an overall air quality.
- Utilized to bring fresh air in from outside and to keep air moving within the server room.
- Keeps balance of temperature by replenishing controlled air to cabinets and devices
- Stabilizes facility air pressure

AIR CONDITIONING

- Purpose is to control air temperature by a set of components.
 - Air Handler
 - Chiller
 - Cooling Tower or Fluid Cooler
- Heat transfer occurs outside server room and usually to exterior environment
- Multiple types of solutions exist for the IT industry.
- Different sizes of Data centers require different solutions which can mean a significant investment depending on the size of the data center

SYSTEM TYPES

- Air Cooled
 - 2 Piece
 - Self Contained
 - Glycol Cooled
 - Water Cooled
 - Chilled Water
-
- Ceiling Mounted
 - Floor Mounted

AIR COOLED

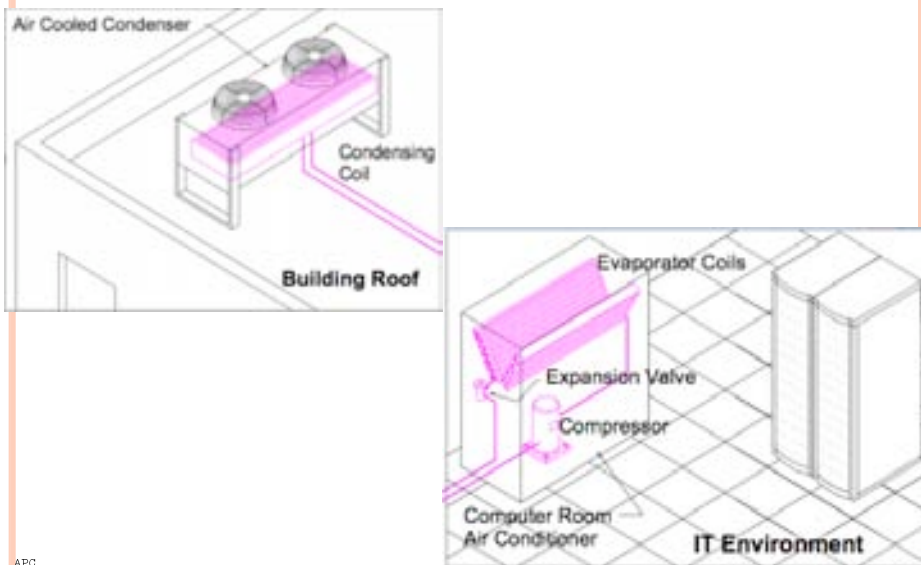

APC

AIR COOLED

- Lowest cost of all solutions to implement.
- Limited range for external component installation
- Ultimately should not be used as a large or medium data center cooling solution.
- Lowest maintenance system available.
- Can not effectively cool systems as liquid based cooling systems.
- Composed of 2-piece system. Cooling system, Air handler (with evaporator coils in air handler)

GLYCOL COOLED

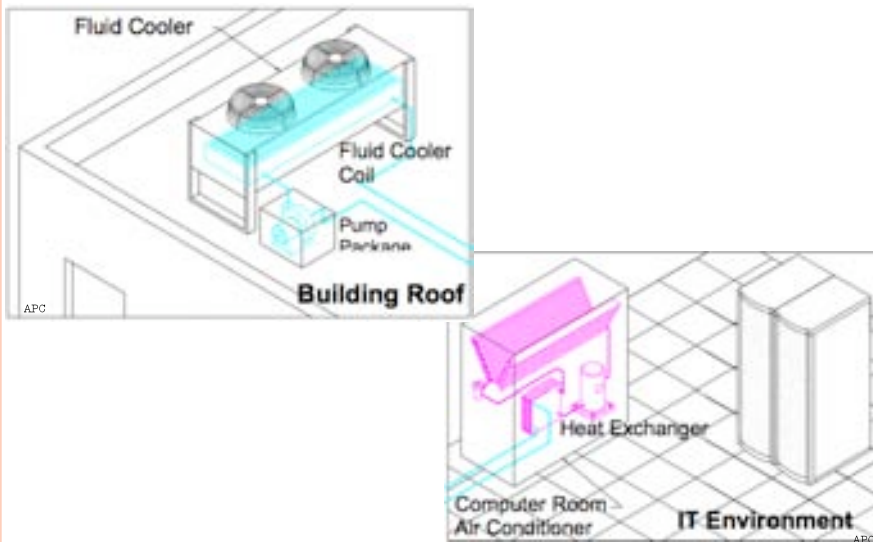

GLYCOL COOLED

- Glycol is similar to car antifreeze
- Great for Northern Locations (free cooling)
- Utilizes Heat exchanger instead of Compressor
- Higher initial cost and lower long term
- Longer distances are capable
- A single system can service multiple units
- Good solution for medium to large datacenters

WATER COOLED

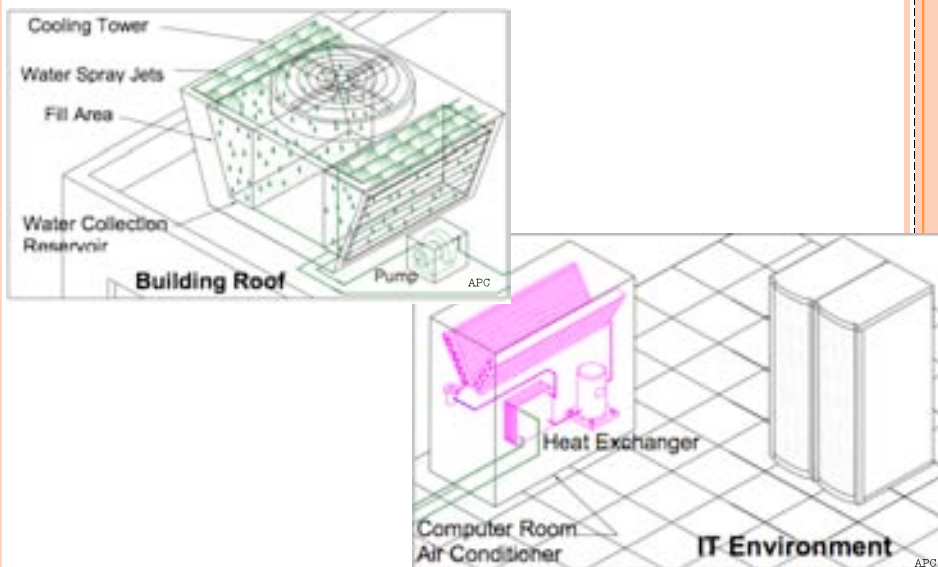

WATER COOLED

- High initial cost (Cooling Tower, Pumps, piping)
- Longer distances are capable
- High maintenance costs for water changes, cleaning and system checking.
- A single system can service multiple units
- Okay solution for medium to large datacenters. Should be utilized with another system to provide a total solution.
- Reliability?

CHILLED WATER

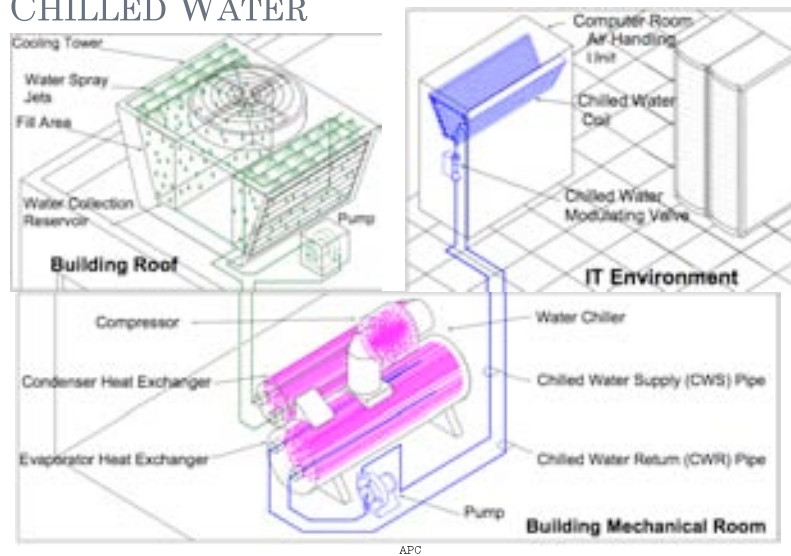

CHILLED WATER

- High initial cost (Cooling Tower, Pumps, piping)
- Longer distances are capable for piping externally.
- Lowest cost to run per kW in large environments
- A single system can service air handlers
- Extremely reliable
- Need for humidifier systems.
- Good for large data center environments.

HUMIDITY CONTROL

- Humidity is the amount of water vapor in the air.
- Humidity Control is defined as the regulation of how much water vapor is within the server room environment
- Normal operating range for electrical devices is from 20% → 80%
- Optimal levels are in the range of 45% to 55%
- Devices for control can exist within the air handler or could be implemented in a standalone solution in high humidity environments.

HUMIDITY CONTINUED

- Humidity should not be considered a defined amount.
- The amount of humidity will vary minute to minute thus a safe range should be established (+/- 10%)
- Relative Humidity is the amount of water vapor in the air in relation to its capable carrying amount.

THERMAL DESIGN

- Discerns how air flows within the datacenter
- Also concerns what type of cooling infrastructure is installed within the data center.
- Can lower energy bills within the data center
- Helps dissipate pockets of hot air to provide optimal air flow and keep devices at a lower temperature.
- Tools available to test and remediate thermal leaks and patterns
- Overhead design or Under floor design?
- Rack/Cabinet layout?

THERMAL DESIGN

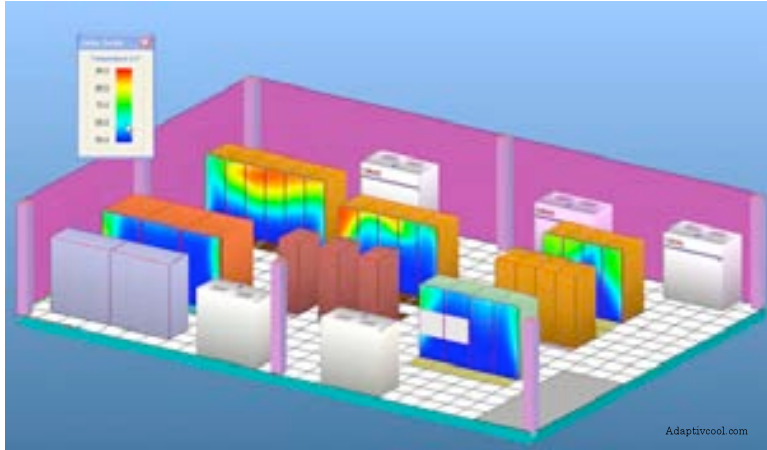

OVERHEAD OR UNDER FLOOR

- These types of design are in relation to the type of plenum installed with the datacenter.
- The airflow should be guided to the cabinet openings for optimal air flow.
- Under floor provides a pressurized area for air to be released when necessary (perforated floor tiles)
- Under floor used in larger datacenters and where raised flooring is present
- Overhead should be used where raised flooring is unavailable
- Uses gravity to provide an overall cooled environment

RACK/CABINET LAYOUT

- Designates airflow pattern from intake to exhaust and how air handlers will receive air back.

- Design types:
 - Cold/Cold
 - Cold/Hot

- Which type works best?
- What type of installation is used to the right?

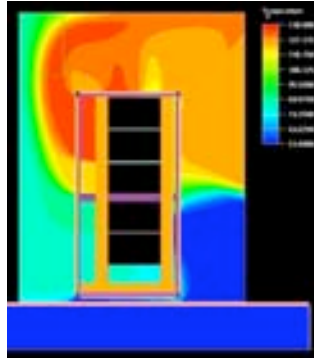

TOOLS AVAILABLE

- Bilometer - Measures airflow in CFM (Cubic Feet per Minute). These systems are very robust and can create flow diagrams based off of measurements taken.



- Thermal Cameras – Visually can show airflow patterns and where warm air pockets are developing



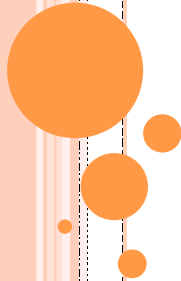

**4055-883-39 &
4055-883-90
ENTERPRISE NETWORKING**

**Week 5
Security**

TODAY'S AGENDA

- **Security**
 - **Physical Security**
 - Surveillance
 - Safeguard systems
 - Access control systems
 - **Heat/Water Prevention**
 - Fire Suppression
 - HVAC/Air Quality control
 - Water/Moisture prevention
 - **Personnel Safety**
 - Policy management & enforcement
 - Fire codes
 - Building codes
 - Access control management



PHYSICAL SECURITY

- Protection of servers and information from vandalism, accidental damage, espionage, theft, and system compromise.
- Methods of remediation include:
 - Physical Locks
 - Access Control Systems
 - Surveillance Systems
 - Fencing
 - Traps
 - Security Presence

PHYSICAL LOCKS

- #1 priority to secure physical objects
- Rack Locks
 - Keep spare keys in central location like a keybox – People do lose keys!
- Door Locks
 - Heavy duty locks contains higher number of pins in the tumbler. Harder to pick.
 - Keep record log of who has what key and dates to correspond
- Cage/Room Locks (colocation)
 - Similar to Door locks, these locks should be maintained in a fashion so that record keeping is known
- Loading Dock Locks
 - These prevent un-authorized access to the loading dock, which is many times an easy backdoor target of a datacenter.

ACCESS CONTROL SYSTEMS

- Should be used in a fashion with the lock system
- Allows for automated management of authorized access
- Implemented via 'badge' or 'access card'
- Linked to either the building management system or its own central system.
- Allows for temporary access to vendors, maintenance personnel or customer access
- Magnetic force applied to lock and disabled when access is granted.
- Can be strengthened with Biometric systems to check fingerprints for a second challenge

ACCESS CONTROL SYSTEMS



SURVEILLANCE SYSTEMS

- Surveillance or Closed Circuit systems provide a real-time account of access control and historical evidence to determine events at different locations.
- Provides best way to determine who is *really* going in and out of the data center
- Can be implemented with a recorder to keep records for periods of time.
- Utilize non-IP solutions for protection/hacking
- Determine if HR policies allow for recording or surveillance of employee activity.

FENCING

- Added as an extra protection for the facility to deter malicious activity near or around the facility.
- Fencing can also be utilized within a server room
 - Cages can be implemented in a co-location scenario to separate customer equipment or to segregate different locations of a server room to provide better control
- Ensure to provide locks and sealing capabilities for customers that want to secure the cages.
- Fencing only provides a certain level of security as opposition to solid walls.

TRAPS

- Used as a safeguard system to prevent free access to resources based on credentials.
- 'Man Traps' are commonly used at all entrances to prevent door propping, and unrestricted access to resources.
- The trap allows only 1 door to be opened at a given time and requires both doors closed to utilize access systems on the second door

SECURITY PRESENCE

- Provide the presence of a security guard during extended business hours or 24 hours to promote the image of a secure location.
- Post signs that alert customers, vendors and internal personnel about the security systems implemented in the data center.
- Constant update of security devices and tests should be completed to ensure that all systems are in correct working order.
- Policy enforcement creates a safer environment for the datacenter and lowers risk levels for malicious activity to occur.

HEAT/WATER PREVENTION

- High Heat levels can create an environment that is inefficient and can damage equipment if tampered or poorly designed.
- Cooling the air within the server room is not the only solution for a higher tier data center.
- Water in any form can be devastating to electrical equipment.
- This includes fire suppressant which even though could mitigate fires, water systems would cause damage and could jeopardize data backup systems as well.

FIRE SUPPRESSION

- Many systems exist other than water or classic systems. These gas system don't harm servers.
- Common data center suppression types include:
 - Inergen (IG-451)
 - Comprised of nitrogen, argon, and carbon dioxide
 - Argonite (IG-55)
 - Comprised of argon and nitrogen
 - FM-200/HFC-227
 - Comprised of heptafluoropropane. Can create hydrofluoric acid under intense heat.
 - Most used in the United States
 - FE13-HFC-23
 - Comprised of trifluoromethane. Absorbs heat from fire until extinguished.

AIR QUALITY

- Air Quality should be sampled often in a datacenter.
- Typical system include a central system which polls air samples from various locations in the server room.
- Sampling checks for smoke, particles and other gaseous material that may be potential hazard.
- Systems are extremely sensitive in comparison to traditional alarm systems.
- Turn off or down systems when construction or maintenance is being performed inside the data center to prevent false alarms.

WATER PREVENTION

- High levels of humidity can cause short circuiting and condensation in server systems.
- Water leaking onto flooring such as ground flooring can cause electrical issues, and in the event server systems are not lifted high enough off of the ground can cause damage.
- In raised flooring, electrical wiring is usually located in subflooring and water will cause damage.
- Implement water sensing equipment to determine when water has breached server room walls.
- Waterproofing of the flooring is highly recommended for water prevention within the subflooring.

POLICY MANAGEMENT

- The most important part of securing the data center.
- Create a policy that defines who can and cannot be allowed within the datacenter
- Define how access is granted and what time periods are defaulted for length
- Emergency access? How long and what notification(s) are necessary?
- Penalties and review specifications should be covered within this document
- *Will not cover all scenarios!*

POLICY MANAGEMENT CONTINUED

- Change Management Policy
 - This controls when and what types of changes are allowed within the datacenter
- Should specify notification times, contact information and what information is necessary for approvals.
- Specify certain maintenance windows that allow changes to be made on a regular basis.
-

FIRE & BUILDING CODES

- Ensure that **ALL** work within the data center is performed under all national and local building and fire codes.
- Refer to **NFPA** for all questions or concerns regarding any facet of the data center.
- NFPA 70 & 75 Covers Electronic Data Processing Equipment in the US.
- Review local and state laws regarding any part of the data center that might be in question.

ACCESS CONTROL MANAGEMENT

- This should be contained within policies defined for the security of the data center.
- Customized time periods should be defined to review and audit the access grants within the datacenter. Expired customers or employees should be removed to protect the assets within the data center.
- Review of logs should be performed to review any breaches of security and can be used to determine actions to better the security features of the datacenter.

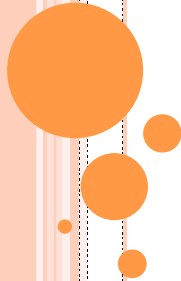

4055-883-39 &
4055-883-90
ENTERPRISE NETWORKING

Week 7
Disaster Recovery

TODAY'S AGENDA

- Backup Systems
 - Onsite storage
 - Tape and Disk Backup systems
 - Removable media
- Offsite storage
 - Long-term storage solutions
 - Site replication
- Test procedures
 - Policy development
 - Redundancy
 - Electrical
 - Data
- Multiple ISP
 - Protocols (BGP, EIGRP)



BACKUP SYSTEMS

- Systems developed to provide short-term, long-term data recovery.
- Integrate into infrastructure via existing network, or dedicated network
- Provides the ability to quickly restore working order from a broken or corrupted system
- Creates a “restore point” for system maintenance and large application or hardware based changes
- Allows for a smaller overall footprint through compression.
- Security concerns?

SYSTEM TYPES

- **Tape Systems**
 - Convert digital data stored on disk systems and convert the data to storage on magnetic tapes.
 - Multiple system formats:
 - Single Drive
 - 1 Drive
 - 1 Tape
 - Tape Library
 - Multiple Drives
 - Holds up to 1,000's of Tapes
- **Disk based systems**
 - SAN Based Systems
 - NAS Systems
 - Local System Storage
- **Optical Systems**

TAPE TECHNOLOGY

- 1/2" tape width is the typical tape standard used
- DLT (1984)
 - Up to 60MB/sec written
 - Current version DLT-S4
- LTO Ultrium (2000)
 - Most Popular tape technology used today. Maximum of 400GB/800GB Compressed.
 - Up to 160MB/s written
 - Most popular technology in industry.
- T10000 (2006)
 - Up to 120MB/s written
 - Holds up to 1TB/tape

TAPE SYSTEMS

- Single Drive
 - Convenient for taking backups of single systems or small infrastructure environments
 - Low implementation cost
 - Limited amount of concurrent backup space
 - Requires manual intervention of tape rotation
 - Consumes internal system space and resources
 - Processor resources
 - Memory Resources
 - Provides quick restoration of lost local system data



IBM Corp.

TAPE LIBRARY

- Larger system consisting of multiple drives, robotic systems and storage for hundreds to thousands of tapes
- High implementation cost.
- Take considerable amount of rack/floor space depending on size.
- Alleviates resources on end system
- Smaller limit of backup space
- Less manual intervention for tape changes/cleaning.
- Ideal for data center and large infrastructure environments.

TAPE LIBRARY CONTINUED

- Connection from systems occurs over high speed bus connections (HBAs, SCSI, GbE, etc)
- Software required to schedule, index, locate and monitor all systems connected to library
- <http://www.youtube.com/watch?v=p63EUrrw8jY>



SotrageTek

DISK BASED SYSTEMS

- Storage Area Network solutions
 - Disk based for fast write/read speeds
 - High cost for maintenance and implementation
 - High redundancy between components
 - Connects via Fibre Channel, SCSI, or Ethernet
- Local Storage
 - Uses disks or separate partitions for backups.
 - Low reliability in the event of system failure.



Audai Corp.

OPTICAL SYSTEMS

- Comprised of CD or DVD burning systems
- Medium Cost for implementation
- Slow write speeds Max (25MB/s)
- Good for small to medium sized centers.
- Shelf life lower for long term solutions
- Used commonly in single system backup solutions
- Higher manual intervention for media changes.
- Media is low cost (~\$.10 → \$.75) disc



REMOVABLE MEDIA

- As external drives and media have advanced with higher storage densities, they are becoming commonplace for backup usage in short-term.
- Should NOT replace conventional backup solutions
- Write speeds increasing



OFF-SITE STORAGE

- Provides a safe locations for critical backup data
- Provider should be bonded for protection
- Location should be utilized for other types of data backup.
- Backup media should be stored in fire-proof containers to ensure that they are safe from environmental damage.
- Provides maximized shelf life for medium
- Allows for recovery in the event of total loss.
- Implementation of media rotational policy allows for archiving and reuse of media.

SITE REPLICATION

- Allows for copies of files, databases, and other information to be transferred simultaneously to another site for DR.
- Utilizes network resources to accomplish task
- Implementation cost can be high for hardware at remote site to accept information.
- Provides high failover and reliability in the event of a data center outage.
- Should be implemented with global failover technologies.

TESTING

- While setting up disaster recovery technologies is a good forethought, testing and stressing these implementations ensures that the setup works correctly.
- Testing from the environmental (HVAC,electrical) levels down to the server level. (data)
- Test all facets of each system for full understanding.
- Document all processes needed to fully provide a redundant system; include all manual steps necessary.

POLICY DEVELOPMENT

- To ensure that processes are followed when new equipment, systems or features are added to the data center, create a policy that outlines which steps need to be taken to ensure that disaster recovery is kept in mind and implemented.
- Locate the policy in a central place where all vendors, and employees will be able to utilize the policy.

REDUNDANCY

- Test all components for redundancy:
 - Network
 - HSRP, Dual connection, Power redundancy within components
 - Electrical
 - Circuit consistency, power strip capabilities, backup power (UPS & Generator)
 - HVAC – Check system failures

ELECTRICAL REDUNDANCY

- **Circuit consistency**
 - Check to ensure that amperage specified actually will trip the breaker at that amount
- **Power strip integrity**
 - Check that power strips are rated at the designed amperage
- **Backup Power**
 - Check UPS for runtime length vs current load
 - Test generator function and failover capabilities
 - Policy and scheduled tests of this facet should be mandated

DATA REDUNDANCY

- **Check for correct redundancy implementation from:**
- Protocols (BGP, EIGRP, HSRP etc)
- Dual connection failover (NIC teaming)
- Switch failover/router failover

8.4 Midterm Exam Example Questions

4055-883 Data Center Design and Networking Midterm Exam Questions

1. Please describe the hierarchy commonly referred to in data center network design. Explain activities that occur at those layers, their function and types of devices that exist at these layers.
2. This type of cabling design provides a hierarchy of cabling:
 - a. Cat 5e
 - b. Distributed
 - c. Aggregation
 - d. Direct
 - e. None of the above
3. _____ provides the ability for systems to remain online while another portion of the network may be failed.
4. This type of fiber optic cable provides faster data transmission speeds over longer distances.
 - a. Multimode
 - b. Single mode
 - c. Mega mode
 - d. Dual pair
5. Scenario: The organization you work for has purchased new switches for the data center that run only on DC power. Your existing switches utilize AC power and you do not have any DC power available within the data center. Provide a solution to utilize these switches within the data center and provide justification for your answer.
6. Name and explain two benefits to utilizing DC power within the data center.
7. Name and explain two benefits to utilizing AC power within the data center.

8. Scenario: The organization that you are designing a data center for is comparing raised floor versus flat floor installation. The maximum height of the raised floor that they could install would be 17 inches due to building code. Based off of this information please provide a recommendation for raised flooring or flat flooring. Discuss reasons for your choice and reasons why the other choice was not made.
9. Ensure that UPS devices or PDUs are not utilized above _____ percent
10. Which of the following cooling technologies would benefit a data center in Rochester the best?
 - a. Air Cooled
 - b. Water Cooled
 - c. Glycol
 - d. Fan Based
 - e. None of the above
11. Normal humidity operating range is from 20% to _____% humidity
12. An air _____ is an enclosed space utilized in data centers to provide airflow.

8.5 Midterm Exam Example Questions

4055-883 Data Center Design and Networking Final Exam Questions

1. Scenario: You are consulting for an organization where the finalization of security designs is occurring for a new data center and the organization is looking to you to provide recommendations on physical security. The organization is a web hosting organization that processes credit card payments through a series of e-commerce sites. The organization would like to implement a maximum of three (3) different physical security technology solutions to provide access control over not only the data center in general, but to the server room as well. Please provide three different recommendations of physical security to protect the payment card systems and justify the reasons to recommending these systems.

2. What is usually the most susceptible location to physical break-ins of a data center:
 - a. Back door
 - b. Front door
 - c. Loading dock
 - d. Roof access
 - e. None of the above

3. _____ prevent someone from propping a door open and allowing free access to a server room or maintenance room.

4. This tool can be utilized to check air flow patterns and where hot pockets are forming within the data center.
 - a. Radar gun
 - b. Manometer
 - c. Multimeter
 - d. Bilometer

5. Scenario: In the data center you work within, your building monitoring system continually warns of smoke particles in the environment, however all systems have been tested to be clean. This occurs frequently when other employees are located within the server room or maintenance is being performed. Discuss what steps should be taken to remedy this situation. Justify your answers.

6. Name two techniques to prevent water damage to the data center.

7. Which of the following organizations provides a standard for the protection of computer equipment?
 - a. National Electrical Contractors Association
 - b. Institute of Electrical and Electronics Engineers
 - c. National Fire Protection Association
 - d. Telecommunications Industry Association
 - e. Electronics Industries Alliance
 - f. None of the above
 - g. All of the above

8. This protocol can provide redundancy and failover capabilities at the edge layer
 - a. OSPF
 - b. RIP
 - c. BGP
 - d. IGP
 - e. None of the above

9. This type of tape library system has historically provided the most interior space with the least footprint in the data center
 - a. Helical
 - b. Linear
 - c. Tower
 - d. Hexagon
 - e. None of the above

10. Scenario: A data center is being implemented in New York City, NY. The organization also owns an existing data center located in Seattle, WA. The organization wants to create a site replication solution to provide critical files and data base backups to the existing data center in Seattle. **Explain two different solutions that the organization may utilize to connect and transfer files of these types to the remote location and how they can easily replicate their data center at this location.** You can assume that their topology at both locations will be identical and that no configuration of systems will be necessary.

9 References:

"80Plus Program." The 80 PLUS Program. 13 Jan. 2009 <<http://80plus.org/80what.htm>>.

"AC, DC and Electric Signals." Electronics Club. Ed. John Hewes. 4 June 2007. 13 Jan. 2009 <<http://www.kpsec.freeuk.com>>.

Al-Fares, Mohammad, Alexander Loukissas, and Amin Vahdat. "A Scalable, Commodity Data Center Network Architecture." Thesis. A Scalable, Commodity Data Center Network Architecture ACM (2008): 63-74.

Alger, Douglas. Build the Best Data Center Facility for Your Business. New York: Cisco Press, 2005.

Arregoces, Mauricio, and Maurizio Portolani. Data Center Fundamentals. New York: Cisco P, 2003.

Berkowitz, Howard C. "Defining an Architecture." Designing Routing and Switching Architectures for Enterprise Networks. By Howard C. Berkowitz. Grand Rapids: New Riders, 1998.

Blazek, Michele, Huimin Chong, Woonsien Loh, and Jonathan G. Koomey. Data Centers Revisited: Assessment of the Energy Impact of Retrofits and Technology Trends in a High-Density Computing Facility. Thesis. ASCE, 2004. Journal of Infrastructure Systems, 2004.

Caldwell, Chris. "Power Supplies: Making the Leap to Higher Efficiency." Presentation to APEC. Texas, Austin. 4 Feb. 2009.

Creswell, John W. Research Design. Thousand Oaks: SAGE Publications, 2003.

Data Center Energy Benchmarking Case Study. Oakland: Lawrence Berkely National Laboratory, 2007.

"Data Center Security." ePayments Network. 20 Jan. 2009. 20 Jan. 2009 <<http://www.epaymentsnetwork.com/DataCenter/tabid/124/Default.aspx>>.

DiMinico, Chris. "Telecommunications Infrastructure Standard for Data Centers." Telecommunications Infrastructure Standard for Data Centers. 25 Jan. 2009. IEEE.

Dunlop, Jodi. "Data Center Case Studies Focus of ASHRAE Book." ASHRAE. 7 May 2008. ASHRAE. 20 Jan. 2009 <<http://www.ashrae.org/pressroom/detail/16715>>.

- Hamilton, James R. An Architecture for Modular Data Centers. Thesis. Microsoft, 2008. Redmond: Microsoft Corporation, 2008. IEEE. 13 Jan. 2009 <http://www.ieee802.org/3/hssg/public/nov06/diminico_01_1106.pdf>.
- Kerr, Devon. Network Hierarchy.
- Kovacs, Brian. Data Center Outsourcing Case Study. Rep. Carmel, IN: NFrame, 2004.
- "Mainframe History." Mainframe History. IBM. 4 Feb. 2009 <http://www-03.ibm.com/ibm/history/exhibits/mainframe/mainframe_intro.html>.
- Mitchell, Robert L. "Case Study: Wells Fargo's Free Data Center Cooling System." Computer World. 5 Nov. 2007. 4 Feb. 2009 <<http://www.computerworld.com/action/article.do?command=viewArticleBasic&articleId=299301&pageNumber=2>>.
- Patrizio, Andy. "Clean Your Datacenter, Cut Your Electric Bill." Internet News. 29 Jan. 2009. 4 Feb. 2009 <www.internetnews.com/hardware/article.php/3799451>.
- Rasmussen, Neil. AC vs. DC Power Distribution for Data Centers. Publication. American Power Conversion, 2007.
- Oppenheimer, Priscilla. Top-down Network Design. New York: Cisco P, 2004. Google Books. Google. 12 Jan. 2009 <http://books.google.com/books?id=YKWfuGGSmXMC&pg=PA141&lpg=PA141&dq=access+layer+hierarchical&source=web&ots=HklxUBvlep&sig=M8h96f9fK_9rBLmt-nb4sWZvVCE&hl=en&ei=Q5qPSfW4NJ6DtweQxtGDCw&sa=X&oi=book_result&resnum=2&ct=result#PPA143,M1>.
- Sharma, Ratnesh K., Rocky Shih, Cullen Bash, and Chandrakant Patel. "On Building Next Generation Data Centers." ACM (2008).
- Snevely, Rob. Enterprise Data Center Design and Methodology. Upper Saddle River: Prentice Hall PTR, 2002.
- Sun, Jimeng, Evan Hoke, John D. Strunk, Gregory R. Ganger, and Christos Faloutsos. "Intelligent System Monitoring on Large Clusters." Thesis. Intelligent System Monitoring on Large Clusters ACM (2007): 47-52.
- TIA-942 Data Center Standards Overview. Publication. Minneapolis: ADC, 2006. "What is Network Cabling." What is Network Cabling. 14 May 2008. University of Southern Florida. 12 Jan. 2009 <<http://fcit.usf.edu/network/chap4/chap4.htm>>.