

Rochester Institute of Technology

RIT Digital Institutional Repository

Theses

7-2019

Design of a Multiband Stacked Microstrip Patch Antenna for Satellite Communications Application

Hadef Ahmed Alshamsi

Follow this and additional works at: <https://repository.rit.edu/theses>

Recommended Citation

Alshamsi, Hadef Ahmed, "Design of a Multiband Stacked Microstrip Patch Antenna for Satellite Communications Application" (2019). Thesis. Rochester Institute of Technology. Accessed from

This Thesis is brought to you for free and open access by the RIT Libraries. For more information, please contact repository@rit.edu.

Design of a Multiband Stacked Microstrip Patch Antenna for Satellite Communications Application

by

Hadef Ahmed Alshamsi

A Thesis Submitted in Partial Fulfillment of the
Requirements for the Degree of Master of Science in Electrical Engineering

Department of Electrical Engineering and Computing Sciences

Rochester Institute of Technology – Dubai

Dubai – UAE

July, 2019

Design of a Multiband Stacked Microstrip Patch Antenna for Satellite Communications Application

by

Hadeef Ahmed Alshamsi

A Thesis Submitted in Partial Fulfillment of the Requirements
for the Degree of Master of Science in Electrical Engineering
Department of Electrical Engineering and Computing Sciences

Approved by:

Date:

Dr. Bouthaina Talili

Thesis Advisor – Department of Electrical Engineering and Computing

Date:

Dr. Abdulla Alzarouni

Thesis Committee Member – Department of Electrical Engineering and Computing

Date:

Dr. Jinane Mounsef

Thesis Committee Member – Department of Electrical Engineering and Computing

Abstract

In this thesis, a multiband stacked patch antenna for satellite communications is proposed. Since handheld devices used for satellite communications are mainly monopole antennas, this thesis explores the possibilities of developing a microstrip patch antenna that can be integrated in the satellite communications' handheld devices. Therefore, a designed antenna for satellite communications that operates around the two bands 1.487 GHz and 1.578 GHz is proposed. The antenna composes of two stacked patches with total dimensions of 45 x 45 mm and 40 x 40 mm for the lower and upper patches, respectively, separated by FR_4 as a dielectric material. The proposed antenna is designed using the method of moments simulator of ADS and the simulations results show good performance in satellite communications bands with gain of 3.42 dBi and circular polarization from 1.453 GHz to 1.478 GHz. Additionally, the antenna shows multiple matching frequencies that can be used for other purposes along with the satellite communications. Moreover, this antenna is simple, easy to fabricate and manufacture, and implement on different devices comparing to other monopole antennas that serve the same purpose.

Table of Content

List of Figures	VI
List of Tables	XI
List of Terminologies and Symbols	XII
Acknowledgement	XIII
Chapter I	1
Introduction	1
Chapter II	3
Satellite Communication	3
Chapter III	7
Microstrip patch antenna	7
3.1 Antenna Parameters	8
Chapter IV	12
Literature Review	12
4.1 Single Patch	13
4.1.1 Slots on the radiating element	13
4.1.2 Feeding methodology	19
4.2 Multiple Patches	22
4.3 Multiple Patches with air gap	33
4.4 Antenna performance enhancements techniques	41
Chapter V	49
Introduction to ADS and a Sample Simulation	49

5.1 Sample antenna design using ADS	49
Chapter VI	58
Design of a Multiband Stacked Microstrip Patch antenna for Satellite	
Communications	58
6.1 Design of Simple Microstrip Patch antenna that radiates at 1.6 GHz ...	59
6.2 Improving the antenna bandwidth at the resonant frequency	72
6.3 Modification to the antenna to obtain more resonant frequencies	82
6.4 Antenna Final Design	96
Chapter VII	105
Conclusions and further work	105
References	107

List of Figures

Fig.1, Simple structure of patch antenna [2]	8
Fig.2, Side view of patch antenna [2]	8
Fig.3, Design of the patch antenna [3]	14
Fig.4, Dimensions of the patch antenna [3]	14
Fig.5, Upper band Axial Ratio [3]	15
Fig.6, Lower band Axial Ratio [3]	15
Fig.7 Top of the patch antenna [4]	15
Fig.8 Bottom of the patch antenna [4]	15
Fig.9 Impedance bandwidth at the operating frequency [4]	16
Fig.10 Circular patch antenna with two circular slots [5]	17
Fig.11 Axial ration bandwidth of the circular patch [5]	17
Fig.12 Designed antenna with 4 arc slots [6]	18
Fig.13 AR bandwidth of the two operating bands [6]	19
Fig.14 Square patch antenna and location of CP feeding [7]	19
Fig.15 Antenna design [7]	20
Fig.16 Return loss and impedance bandwidth [7]	20
Fig.17 Designed stacked antenna [9]	23
Fig.18 Stacked antenna parameters [9]	24
Fig.19 S-Slot patch [9]	23
Fig.20 Ground plane [9]	24
Fig.21 Impedance Bandwidth of the antenna [9]	24

Fig.22 Axial Ratio of the antenna [9]	25
Fig.23 Dimensions of the designed antenna [10]	25
Fig.24 Obtained results of the proposed antenna [10]	26
Fig.25 Antenna structure of the work in [11]	26
Fig.26 Antenna structure of the work in [12]	26
Fig.27 The Axial Ration bandwidth of the antenna [12]	27
Fig.28 Proposed patch antenna with multiple patches [13]	28
Fig.29 Two half annular ring antenna [14]	29
Fig.30 Dimensions of the proposed antenna [14]	29
Fig.31 Antenna impedance BW [14]	30
Fig.32 Structure of the proposed antenna in the work [15]	31
Fig.33 Proposed antenna impedance BW [15]	32
Fig.34 Proposed antenna gain [15]	32
Fig.35 LHCP with Coaxial Feed [16]	34
Fig.36 RHCP with side TL Feed [16]	34
Fig.37 Antenna design in the work [16]	35
Fig.38 Antenna design parameter of the work [16]	35
Fig.39 CP AR bandwidth of the antenna in the work [16]	35
Fig.40 Antenna design with cross slots of the work [17]	36
Fig.41 Single patch of the designed array by the work in [18]	37
Fig.42 The design of the proposed array by the work in [18]	37
Fig.43 Axial Ratio bandwidth of the designed array [18]	38
Fig.44 The proposed antenna in the work [19]	39

Fig.45 The proposed antenna with thin substrate in the work [20]	40
Fig.46 Antenna design considering single feed of the work [21]	41
Fig.47 Antenna design with differential plates feeding by the work [22]	42
Fig.48 Antenna design and dimensions [23]	43
Fig.49 Antenna design with fractal E-shaped [24]	44
Fig.50 Antenna with DGS and Cavity Structure [25]	46
Fig.51 Array Antenna with three DGSs [26]	46
Fig.52 Antenna design with Cross slots and SMSH [27]	47
Fig.53 Schematic workspace of ADS	50
Fig.54 Defining the Sectional layers of the antenna	51
Fig.55 Antenna of work [28]	52
Fig.56 Sample Antenna (example) is placed in the layout plane	52
Fig.57 Results of the antenna in [28]	53
Fig.58 Results of the simulated example antenna	54
Fig.59 Surface current of the example antenna	55
Fig.60 Radiation pattern of the example antenna	55
Fig.61 Different parameters of the example antenna	56
Fig.62 Gain and Directivity of the example antenna	56
Fig.63 Absolute Fields of the example antenna	57
Fig.64 Axial Ratio and the Polarization of the example antenna	57
Fig.65 Simplest rectangular antenna	62
Fig.66 Return Loss of the simple rectangular antenna	63
Fig.67 Simplest square antenna	64

Fig.68 Return Loss of the simplest square antenna	64
Fig.69 45 x 45 mm Antenna with corner cuts to achieve circular polarization	66
Fig.70 LineCalc tool in ADS to find the length of the Feeding line	67
Fig.71 Proposed with extended feeding line	68
Fig.72 Antenna with inset matching line	68
Fig.73 Return loss of antenna in Fig.71	69
Fig.74 Return loss of antenna in Fig.72	69
Fig.75 Axial Ratio of the simple antenna	70
Fig.76 Return loss of the simple antenna from 0.5 GHz to 6 GHz	71
Fig.77 Two patch antenna cross section	73
Fig.78 Schematic of the two patch antenna	73
Fig.79 Return loss of the two patch antenna	74
Fig.80 Surface Current of the electromagnetically coupled two patches	75
Fig.81 Antenna cross sections with VIA being added between the two patched	76
Fig.82 Schematic of the VIA	76
Fig.83 Return loss of the Antenna with VIA between the two patches	77
Fig.84 Antenna with Left VIA, and increased VIA conductor size	78
Fig.85 Antenna with Right VIA, and increased VIA conductor size	78
Fig.86 Left VIA return loss	79
Fig.87 Right VIA return loss	79
Fig.88 Left VIA surface current	80
Fig.89 Right VIA surface current	81
Fig.90 Upper Patch bigger than the lower patch	84

Fig.91 Return Loss of the antenna in Fig.90 at 1.5 GHz frequency	84
Fig.92 Upper patch much smaller than lower patch	85
Fig.93 Return loss of the antenna proposed in Fig.92	86
Fig.94 Antenna with two VIAs	87
Fig.95 Return loss of the antenna with two VIAs	87
Fig.96 Slots on the upper patch	88
Fig.97 Return loss of the antenna having a lot in upper patch	89
Fig.98 Cross section of the antenna with 2.5 mm upper substrate thickness	90
Fig.99 Return loss of the Antenna in Fig.98	90
Fig.100 Helix upper patch	91
Fig.101 Return Loss of the Helix upper patch at the resonant frequency	92
Fig.102 Return Loss of the antenna with 2 nd VIA higher than the center line	93
Fig.103 Return Loss of the antenna with 2 nd VIA along the center line	94
Fig.104 Return Loss of the antenna with 2 nd VIA lower than the center line	94
Fig.105 Final Antenna layout with 2 nd VIA lower than the center line	95
Fig.106 Final Antenna Cross Section	96
Fig.107 Final Antenna Layout and dimensions	97
Fig.108 Return loss of the Final Antenna from 1 GHz till 3GHz	98
Fig.109 Return loss from 3 GHz till 6 GHz	99
Fig.110 Axial Ratio of the Final Antenna Vs. Frequency	100
Fig.111 Radiation Pattern of the Final Antenna at 1.487 GHz	101
Fig.112 Surface current on top of the upper patch of the Final Antenna at 1.487 GHz	101
Fig.113 Surface current on top of the upper patch of the Final Antenna at 1.578 GHz	102

List of Tables

Table.1 Comparison between different satellite communication companies [1]	6
Table.2 Dimensions of the designed antenna [7]	20
Table.3 Final Antenna Dimensions	97
Table.4 Designed Antenna Parameters at different design stages	103

List of Terminologies and Symbols

- AR Axial Ratio
- CP Circular Polarization
- MS Microstrip
- Eq Equation
- FR_4 Dielectric Material (Substrate) with electric permittivity 4.6
- Sat Satellite
- dB decibels
- Fig. Figure
- VIA Vertical Interconnect Access
- ADS Agilent's Advanced Design System 2011 Software
- ϵ_r Electric permittivity of a material
- ϵ_{eff} Effective Dielectric Constant
- GEO Geosynchronous earth-orbit
- MEO Medium earth-orbit
- LEO Low earth-orbit

Acknowledgement

I would like to thank Professor Boutheina Tlili to her continuous support and supervision of this research and the full dedication towards a successful design. Moreover, I would like to express my gratitude to Agilent for their donation to the ADS software and RIT – Dubai facilities for the continuous support during the design, simulations and finalizing this thesis.

Chapter I

Introduction

In the last two decades, there have been huge developments in the communication field. From phones to mobile phones up to smart phones in the recent years, the rapid improvements show the amount of researches and enhancements in this field. The accessibility and the usage of the mobile networks and the internet are very critical in almost all the fields like education system, in businesses, in medicine, in space, in oil and gas and many other fields. Therefore, the continuous development in the communication field and its infrastructure is equally important. Looking at the size of the planet and the various scattered human concentrations, rural areas and industries, and vast ocean ships and vessels, makes it very difficult to cover all of these areas with landline communications infrastructure and provide direct access to the different users. As a result, many companies have introduced the idea of the satellite communications in order to overcome the shortcuts that land infrastructure cannot cover and develop.

On the other hand, handheld devices and specially mobile phones have become more compact, and small in size. The antenna of the handheld devices also developed to simpler, easy to fabricate and integrate in the new devices. On the other hand, for satellite communications, the antenna size is still a challenge due to the requirements of the power, and polarization of the signals.

Therefore, in our research we are exploring the different solutions to the antenna requirements of the satellite communications taking into consideration the recent developments and requirements in the handheld devices like the compatibility, ease of fabrication and integration. This thesis proposes a stacked microstrip patch antenna that can be used for satellite communication as well other communication purposes.

The research consists of five main chapters that address different items. Chapter two introduces the satellite communications and the latest developments in this field. Then chapter three, antenna and microstrip patch antenna is being introduced. After that chapter four, the main literature review of the research presenting the latest research and development for the microstrip patch antennas that has circular polarization. Moreover, chapter five, ADS software, which was used in the design, is briefed. Chapter six will have the main design, calculations, and discussion of the proposed antenna. Finally, chapter seven is the conclusion and the future work of this research.

Chapter II

Satellite Communication

In the late 80s and the beginning of the 90s, many companies have introduced the idea of satellite communications. The main idea is using satellites as the main route for the mobile communications and possibly internet access in the future. Since the satellite location, height, and coverage footprint can be huge comparing local infrastructure, the usage of the satellite communications is more convenient, cheaper, and easier to implement comparing to the local infrastructure development. It provides direct access to the rural areas where there is no communication infrastructure. Moreover, it provided continuous coverage to the sea ships and vessels. As the local communications can be affected greatly by shadowing and the existence of the huge buildings and the natural obstacles, in satellite communications these problems do not exist [1]. However, we have to point out that using the satellite communications has its own downfalls comparing to the local communications in terms of the operational costs, delays in the communications paths since the signals have to go to thousands of Kilometers and come back again, and the development of the mobile phones in order to be able to handle the satellite communications is very important. Therefore, many companies like Thuraya, Iridium and others emerged as a solution and as a communication company competitor that will be using satellite communication over the local or land line.

In satellite communication, there are also different types or categories that have to be defined. Mainly, there are three different levels or types of satellite communication antenna which are defined based on the attitude from the earth and the size of the foot print that it can cover on the earth. These three levels are GEO, Geosynchronous earth-orbit, MEO, Medium earth-orbit, and LEO, Low earth orbit [1]. GEO satellites are based from 35800 Km above the equator and higher [1]. GEO satellites can cover one third of the planet. Therefore, three GEO satellites equally spaced can cover the whole planet [1]. The main downfall of these satellites, is the lengthy path that the signal has to propagate through from the hand held device or the phone all the way to the satellite antenna and again back to the other side of the communication. These lengthy paths will affect the delay of the communications, and sometimes the loss of the communications due to attenuation. MEO satellites are placed from 5000 Km up to 12000 Km above the equator [1]. More satellites and antennas are needed to cover the whole planet, but the path and the signal propagation are much less than that of the GEO satellite signals. LEO satellites which are the closest to the planet are placed from the height of 500 Km up to 1500 Km above the earth [1]. More and more antennas are needed to cover the whole planet by the LEO satellites because of the smaller footprint that it can cover on the planet. Moreover, the communication system is not easier as it though comparing to the GEO satellite specially if the two points of communications are far apart and the signals has to propagate through different LEO satellites. Therefore, there are delays in terms of the switching and signals propagating from LEO satellite to another rather than the lengthy path that is caused by the GEO satellite. As a result different companies considered different types of the satellite antennas, different coverage footprints, and different markets to focus on. In the following Table.1 shows a summary of the main companies in this field [1].

Furthermore, there are other issue and challenges the companies and manufacturers of the satellite communications face. The designs of the mobile set itself became more and more complicated comparing to its design in the 90s. The size reduction of the mobile phones along with improving the other features like the screen size, battery lifetime, shape of the phones, applications on the phone, the internal memory, and many other features have affected greatly in the design of the satellite communications mobile set. One of the main aspects that affected the design of the mobile sets is its antenna. The antenna of the mobile phone has changes from the old shape monopoles and dipoles into more compact, easy to fabricate Microstrip patch antennas. From satellite perspectives, implementing Microstrip patch antennas is very difficult because of many factors that are associated with these types of antennas. The most important criteria is the polarization of the radiated signals over the operating band width. In satellite communications, circular polarization is preferred to be used since it is more robust for fading, attenuation, and other factors that affect the signals since these waves are travelling for thousands of kilometers. Therefore, design Microstrip patch antenna that operates for satellite is more challenging.

Table.1 Comparison between different satellite communication companies [1]

System name	Iridium	Globalstar	ICO	Ellipso	Asian Cellular System ACeS	Thuraya
Orbit	LEO	LEO	MEO	LEO	GEO	GEO
Primary Services	Voice, DATA, FAX					
Coverage	Worldwide				Asia Pacific	Middle east, central Asia, India, and East Europe
Initial Launch / start of service	1997 / 1998	1998 / 1999	1998 / 2000	2000 / 2000	1999 / 1999	2000 / 2000
System Cost	4.4 billion \$	2.6 billion \$	4.5 billion \$	1.1 billion \$	1 billion \$	1.2 billion \$
Satellite aloft	66	48	10	14	1 plus spare	1 plus spare
Orbit, Km	780	1400	10355	8040	35800	35800
Satellite lifetime, years	5-8	7.5	12	5-7	12	15
Handset supplier	Motorola, Kyocera	Qualcomm, Telital, Ericsson	Mitsubishi, NEC, Samsung, Ericsson, Panasonic	L3 communications	Ericsson	Hughes Network systems
Frequencies, GHz	Services: 1.616-1.6265 Feeder links: 29.1-29.3 uplink 19.4-19.6 downlink	Services: 1.610-1.6265 uplink 2.4835-2.5 downlink Feeder links: 5.091-5.25 Uplink 6.875-7.055 downlink	Services: 1.985-2.015 uplink 2.17-2.2 Downlink Feeder links: 5.15-2.25 uplink 6.975-7.065 Downlink	Services: 1.610-1.621	Services: 1.6265-1.6605 uplink 1.525-1.559 downlink	Services: Uplink 1.525-1.559 Downlink 1.626-1.660

Chapter III

Microstrip patch antenna

Microstrip patch antennas have been very promising antennas especially in the telecommunications field. They are easy to design, to implement, and cheap to manufacture. They are very compact with the mobile phones design profile, and the performance of these antennas in the past decade has proven its promising future in the mobile communications fields as well as the distributed antennas field. Furthermore, it is much easier to implement one patch antenna in a mobile device than having multiple patch antennas in mobile devices.

The very basic formation of the Microstrip patch is two conducting materials in between them a dielectric material which is called a substrate. The two conducting materials, one will be operating as a ground plane and the other will be acting as a patch or as a radiating element as indicated in the Fig.1, and Fig.2 [2]. Once the upper patch is excited with electromagnetic signal, taking in considerations the operating frequencies of the patch, an electromagnetic signal is de-latched normal to the surface of the patch creating a Microstrip patch antenna. As the researches and developments to these types of antennas increase, different and various shapes, structures, feeding methodologies, materials, fabrications methods, and principles where used. In this research, Microstrip patch antenna that are used for satellite communications is explored along with the possibilities to combine the operation frequency bands of the satellite mobile networks and the local networks in one compact, easy to fabricate antenna.

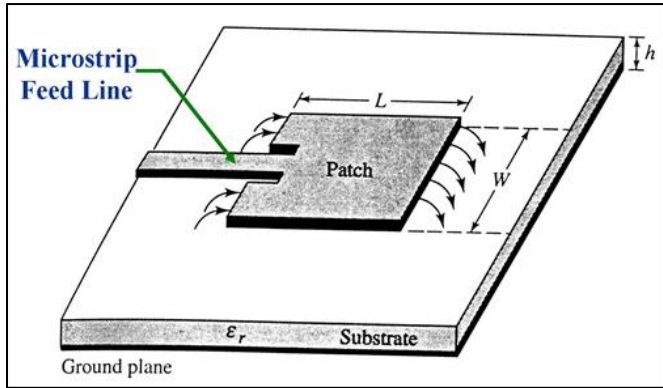

Fig.1 Simple structure of patch antenna [2]

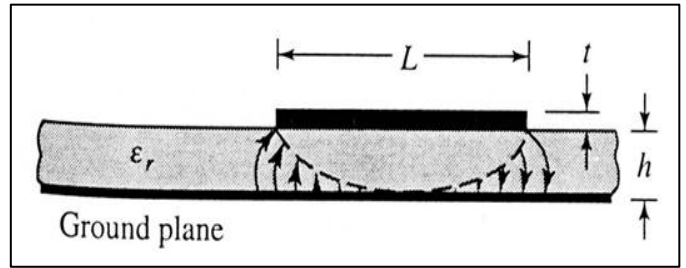

Fig.2 Side view of patch antenna [2]

3.1 Antenna Parameters:

It is important to define different antenna parameters that describe the antenna to be studied or explored. The following are the main antenna parameters that need to be defined before proceeding into the literature review and antenna design:

A- Radiation Patterns:

From [2], radiation pattern is defined as “a mathematical function or a graphical representation of the radiation properties of the antenna as a function of space coordinates. In most cases, the radiation pattern is determined in the far-field region and is represented as a function of the directional coordinates”. The radiation pattern of the antenna can be described as the following:

1- Isotropic:

Isotropic radiation pattern is defined as “a hypothetical lossless antenna having equal radiation in all directions” [2]. Since it does not exist in reality, but taken as a reference for other directional antennas.

2- Directional:

Directional radiation pattern is defined as “having the property of radiating or receiving electromagnetic waves more effectively in some directions than in others” [2].

3- Omni-directional:

Omni-directional radiation pattern is a special type of the directional radiation pattern and it is defined as “having an essentially non-directional pattern in a given plane and a directional pattern in any orthogonal plane” [2].

B- Gain:

There are two main definitions of the antenna gain which are the Absolute Gain and the Relative Gain. Absolute Gain is defined as “the ratio of the intensity, in a given direction, to the radiation intensity that would be obtained if the power accepted by the antenna were radiated isotropically” [2]. On the other hand, Relative Gain is “the ratio of the power gain in a given direction to the power gain of a reference antenna in its referenced direction” [2].

Gain Equation:
$$\text{Gain} = 4\pi \frac{U}{P_{in}}, \text{ where} \quad (1)$$

U is the radiation intensity (Watt / Unit Solid Angle)

P_{in} is the total input power (Watt)

C- Input Impedance:

The input impedance of the antenna is defined as “the impedance presented by an antenna at its terminals or the ratio of the voltage to current at a pair of terminals or the ratio of the appropriate components of the electric to magnetic fields at a point” [2]. It is very important to have a good matching between the feeding lines to the antenna and the antenna in order to have a maximum power transferred to the antennas.

D- Return Loss:

Return loss is one of the most important parameters of an antenna. It basically represents the ratio of the power reflected from a port to that incident power into the port. As the return loss decreases that means the majority of the signal have propagated into the port or the antenna, hence there is a good matching.

$$\text{Return Loss} = -20 \text{ Log } |\Gamma|, \text{ where } \Gamma \text{ is the reflection coefficient.} \quad (2)$$

E- Bandwidth:

The bandwidth of the antenna is “the range of the frequencies within which the performance of the antenna, with respect to some characteristics, conforms to a specified standard” [2]. Usually, the bandwidth of the antenna indicates the range of the frequencies that the antenna has a return loss below the 10 dB.

F- Polarization:

Polarization of an antenna is “in a given direction, the polarization of the wave transmitted (radiated) by the antenna” [2]. For more practical definition, the polarization is defined as “that property of an electromagnetic wave describing the time varying direction and relative magnitude of the electric-field vector”[2]. Polarization of the antenna or a wave can be categorized into three main polarizations which are linear, circular, and elliptical. Axial Ratio is a parameter that is used to define the polarization of an antenna or a wave. Axial Ratio “AR” is defined as the ratio of the major axis of the wave to the minor axis. Therefore, Axial Ratio falls in the following range: $1 \leq AR \leq \infty$

- 1- Linear polarization: when there is no minor axis or very small comparing to the major axis, then AR is ∞ .
- 2- Circular polarization: when the minor and the major axis are equal. Therefore, AR = 1 when there is a circular polarization. However, for practicality, AR = 3dB or less is considered acceptable to consider the wave or the antenna having circular polarization.
- 3- Elliptical polarization: in this case AR is in between the circular and linear polarization. It is to be noted that both linear and circular polarizations are special cases of the elliptical polarization.

Chapter IV

Literature Review

In the literature review, the latest researches, journals, and studies around the globe related to this thesis were explored. Since, satellite communications and Microstrip patch antenna were presented earlier, the following literature review will focus on the Circular Polarization of the antenna and different enhancement techniques that can be used to enhance the performance of the antenna for different other parameters like matching bandwidth or center frequency location. Many studies focused on obtaining circular polarization for microstrip patch antennas. Therefore, our following literature review will present the different studies categorized on four sections which are:

- 1- **Single Patch:** Focuses on the antennas that achieved CP with a single Microstrip Patch antenna.
- 2- **Multiple Patch:** Focuses on the antennas that achieved CP with Multiple Microstrip Patch antennas.
- 3- **Multiple Patches with Air Gap:** Focuses on the antennas that achieved CP with Multiple Microstrip Patch antennas with an air gap in between.
- 4- **Antenna Performance enhancement techniques:** this section presents different techniques that can be used to enhance the performance of the designed antenna in general.

4.1 Single Patch

To achieve Circular polarization there are many ways, but the most important point is the ability to create a disturbance on the surface patch that will lead to a radiation that is of circular polarization. The disturbance is to make the antenna radiates two degenerate modes at the same magnitude but with 90 degrees phase shift between these two modes. Therefore, the disturbance that is to happen to the antenna surface will cause one of the two modes to start radiating at a different frequency which is a lower frequency level. Single patch antenna has been in studies in order to be used for Circular Polarization. That is, to use a simple patch antenna with two metallic surfaces one as a patch surface and one as a ground and between the two plates is the dielectric material. Despite the many disadvantages of the single patch like the leakage current, the narrow impedance bandwidth, and very narrow CP Band width, it is more preferable by the industries and the manufacturers since it is easy to design, manufacture, and having comparatively smaller thickness specially for hand held devices where the size is of high consideration. Therefore, many techniques were introduced in order to improve the characteristics of the single patch antenna to be suitable and more practical to serve the type of radiation, the bandwidth, and the gain of the antenna. In the following discussion two types of the main techniques will be considered that are slots on the radiating element and feeding methodology.

4.1.1 Slots on the radiating element:

One of the main types to obtain a circular polarization is alter the homogenously surface of the patch. Therefore, etching a slot on the patch will lead to alter the pattern and the normal

performance and radiation of the antenna. If the alternation is well designed and implemented, it would lead the patch antenna to radiate a circular polarization pattern. In [3], the author presented a square patch antenna that will have a dual-band CP radiation performance. The CP was obtained by etching a rectangular slot at the center of the and by modifying the location of the feeding transmission line as in Fig.3 and Fig.4.

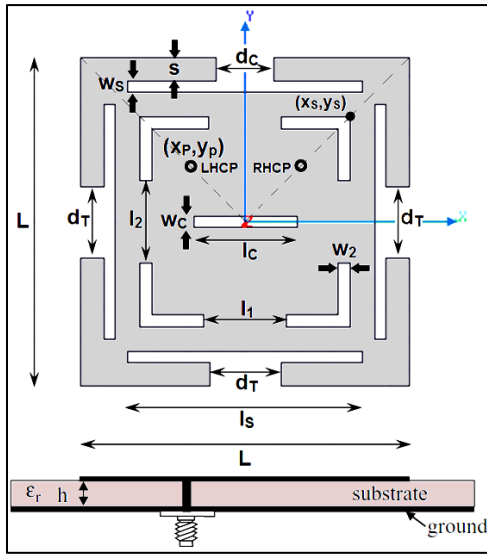

Fig.3, Design of the patch antenna [3]

TABLE I: Parameters of the proposed antenna

Parameters		Parameters	
	Size (mm)		Size (mm)
L	22.6	w_c	0.8
l_s	16.2	x_p, y_p	-3.5, 3.5
w_s	0.8	l_1	5
s	1.6	l_2	5.7
d_T	4.9	w_2	0.8
d_c	4	x_s, y_s	7.2
l_c	7.1		

Fig.4, Dimensions of the patch antenna [3]

After designing the patch antenna, eight extra slots were added to enhance the performance of the antenna and modify the center frequency of the two operating bands. Those eight slots are four T-shaped slots for the upper band center frequency modification, and the other four L-shaped slots are for the lower band. Fig.5, and Fig.6 shows the axial ratio of the two bands. It is obviously the main goal of the design has been achieved, but the other disadvantages haven't been overcome like the narrow band width. On the other hand, in [4] the same concept as in [3] was used which is the etched square slot on the radiating patch. However, rather than using the same technique in enhancing the performance, another square slot was etched on the ground plane to serve the purpose. The square slot on the patch was rotated at 45 degrees in

order to achieve the circular polarization. Since the ground plane have a major effect on the antenna behavior in general and the radiation and its efficiency in particular,

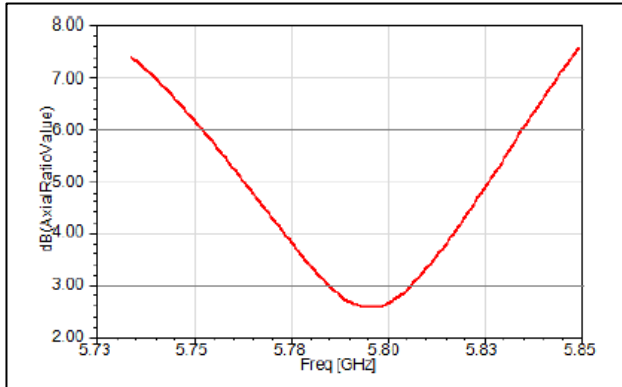

Fig.5, Upper band Axial Ratio [3]

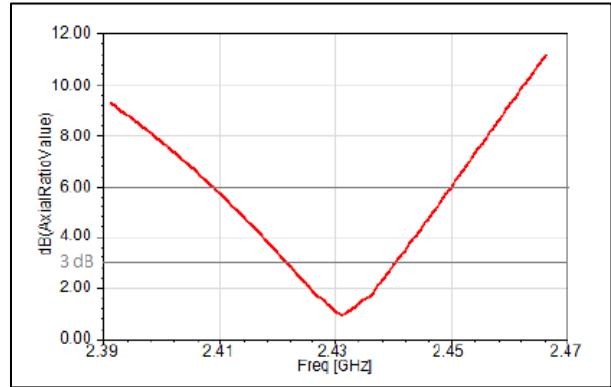

Fig.6, Lower band Axial Ratio [3]

the ground plane was reduced. In order to compensate for the effect of the reduction of the ground plane, two square slots were etched in the ground plane as in Fig.8.

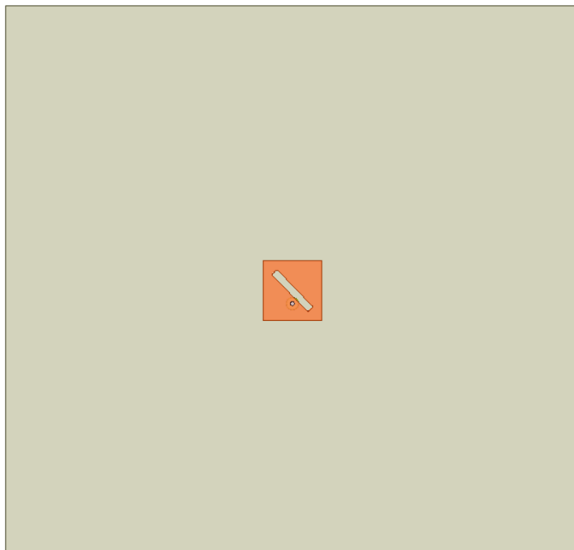

Fig.7 Top of the patch antenna [4]

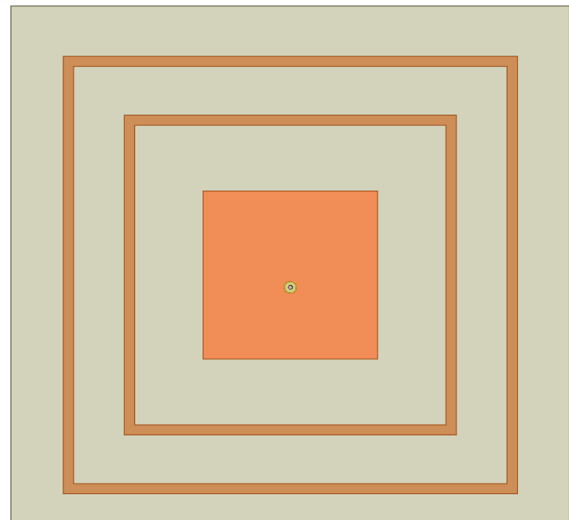

Fig.8 Bottom of the patch antenna [4]

Introducing slots in the ground plane will affect the performance of the antenna in terms of the input impedance, radiation pattern and the AR. As a result, an optimization study carried out in order to choose the best performance of the antenna as it shown in Fig.9. Despite the good performance of the antenna in terms of AR, impedance matching, and radiation pattern of the antenna, still the bandwidth of the operating frequency is narrow since it is only 3% impedance bandwidth.

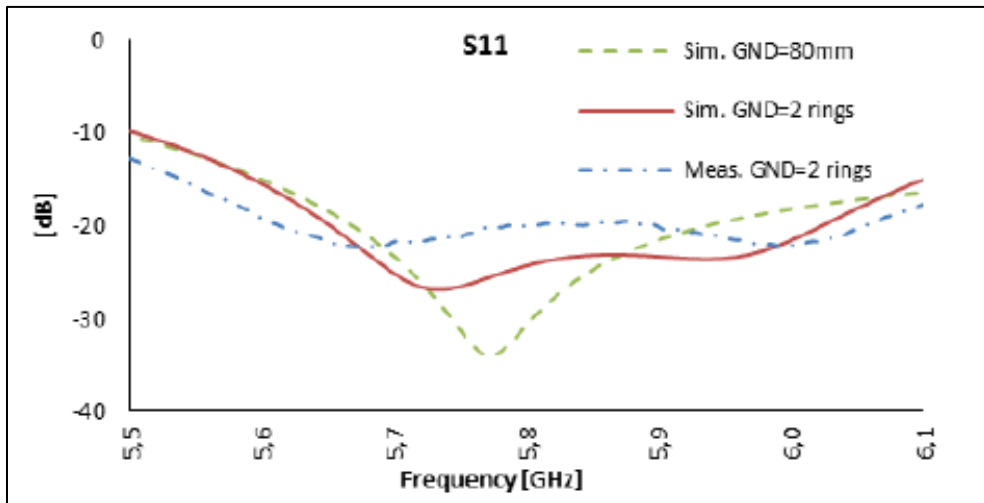

Fig.9 Impedance bandwidth at the operating frequency [4]

In the same content, other researchers investigated the possibility to create a CP radiation antenna using two or more slots. The work in [5], circular polarization radiation pattern was achieved by using two circular slots etched on the radiation surface of the antenna. The dimensions and the locations of these two circular slots were modified to serve the purpose since designing the antenna of the symmetrical locations will lead to a linear polarization. Therefore, carefully choosing the locations and the dimensions will lead to have two degenerate modes radiates with equal magnitude and 90 degree phase-shift. Moreover, these two circular slots which are implemented on a circular patch are of different dimensions as it shown in Fig.10. the results of the designed antenna shows that a good CP can be achieved using the two circular slots

on the patch antenna since the AR can be reach up to 0.5 dB [5]. However, the main disadvantage of this design is the bandwidth of the designed antenna, since the achieved bandwidth is up to 28 MHz as it shown in Fig.11. The success of the concept of adding two circular slots on the patch to achieve CP, haves led other researchers to investigate more shapes and number of slots that can be added to the patch in order to achieve circular polarization. In a goal of achieving dual-band Circular polarization, the work in [6] proposes to use four arc slots

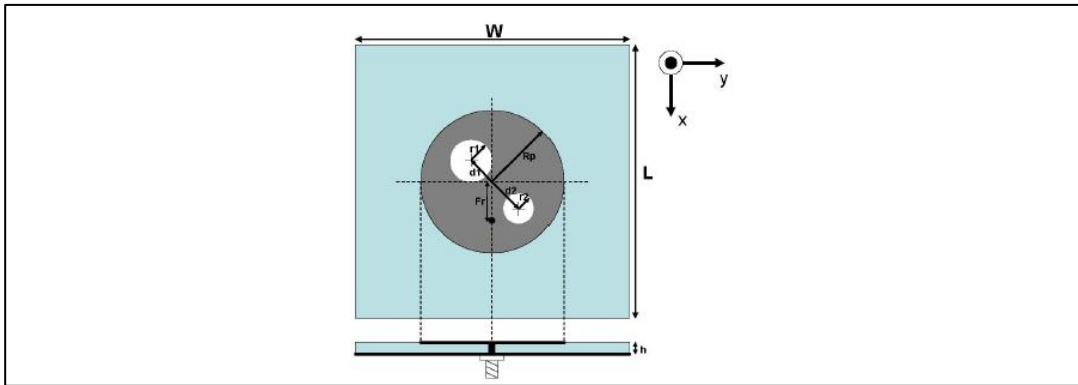

Fig.10 Circular patch antenna with two circular slots [5]

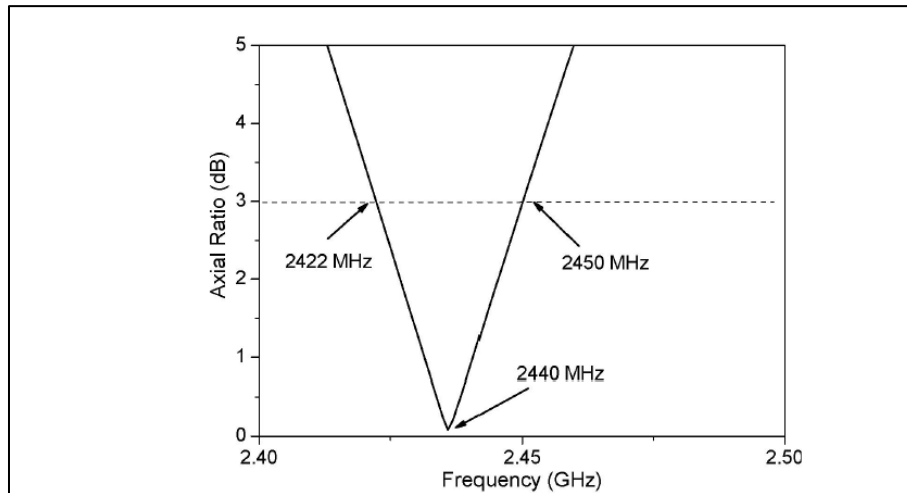

Fig.11 Axial ration bandwidth of the circular patch [5]

on the circular patch. The proposed four arc slots will be located at the edges of the circular patch. Since having four slots of the same dimensions and symmetrical locations will lead to a

linear polarization, the dimensions and the locations of the arc were modified to satisfy the needed radiation polarization. Moreover, in one of the arcs a perturbation lot were added to achieve the best performance of the antenna [6]. In addition, the location of the feeding point on the antenna was chosen in two locations one to operate the antenna in a LH-CP and the other point is to operate the antenna as a RH-CP antenna as in Fig.12. It is important to note that, the two subtending angles play a great role in the CP achieved in the two bands. Moreover, modifying the length and width the protruding slot has an effect in adjusting the operation frequency of the first mode and slightly affecting the other more.

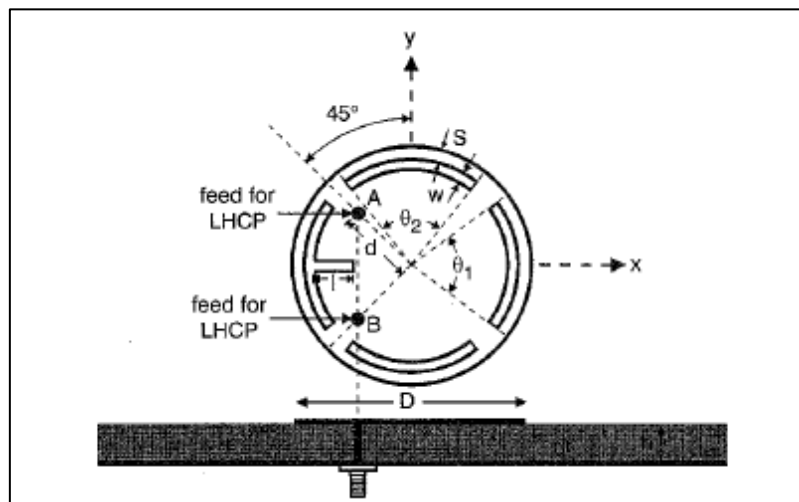

Fig.12 Designed antenna with 4 arc slots [6]

The results of the designed antenna shows a great performance in terms of the achieved axial ratio as in Fig.13. The achieved AR is below 0.5 dB in both bands. In addition, the bandwidth obtained from the designed antenna is about 50 MHz in total for both bands which is slightly greater than the achieved bandwidths in the previous designs. However, this bandwidth still need to be modified in order to serve the larger bandwidth applications.

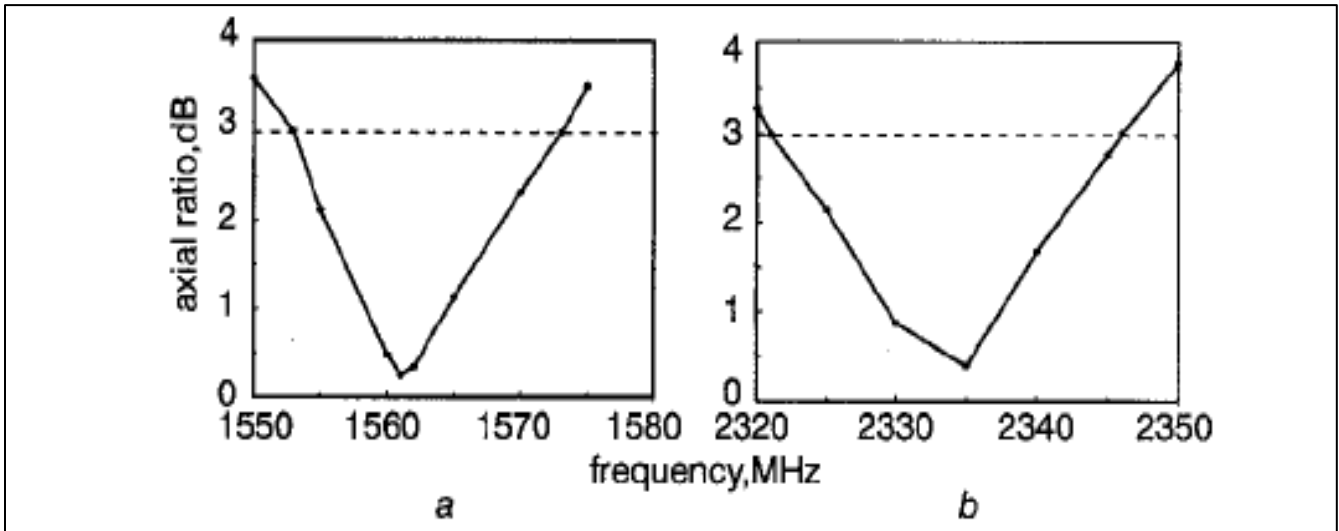

Fig.13 AR bandwidth of the two operating bands [6]

4.1.2 Feeding methodology:

Another method to obtain a circular polarization for a single patch antenna is the location of feeding. It is well known that feeding a square patch antenna at the corners of the antenna will lead to have a circular polarization. Choosing different corners to feed the patch antenna will result in different circular polarization either right handed or left handed as in Fig.14 [7].

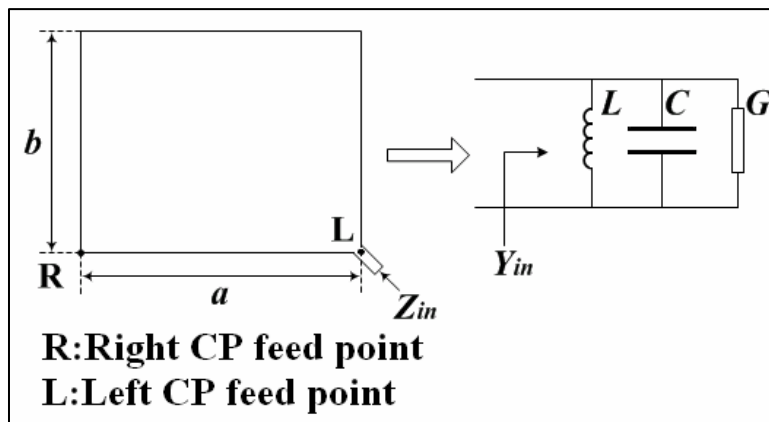

Fig.14 Square patch antenna and location of CP feeding [7]

This type of antenna design is the conventional way of designing CP antennas. However, methods of enhancements can be added in order to improve the performance of the antenna in

terms of the AX bandwidth, antenna gain, and different operation frequencies. In [7], the same principle was used in order to obtain dual-band CP operation. Therefore, a matching network as in Fig.15 has been used in order to operate the antenna at the two different frequencies [7].

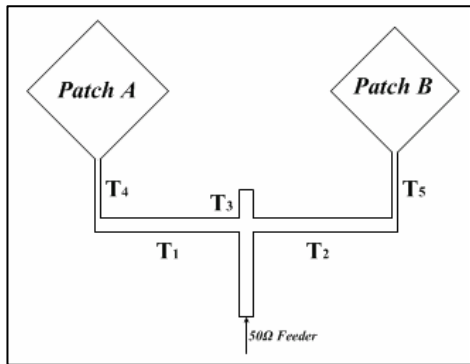

Table.2 Dimensions of the designed antenna [7]

	Length(mm)	Width(mm)
Patch A at 1.9GHz	38.5	37.4
Patch B at 2.4GHz	30.5	29.8
Line T1	21.9	1.9
Line T2	17.3	1.9
Line T3	4.5	1.9
Line T4	22.9	0.7
Line T5	23.0	0.6

Fig.15 Antenna design [7]

The results of the designed antenna shows a good match between the concept and the implementations. The antenna is reported to have a good impedance bandwidth that serve the purpose of the design as in Fig.16 [7].

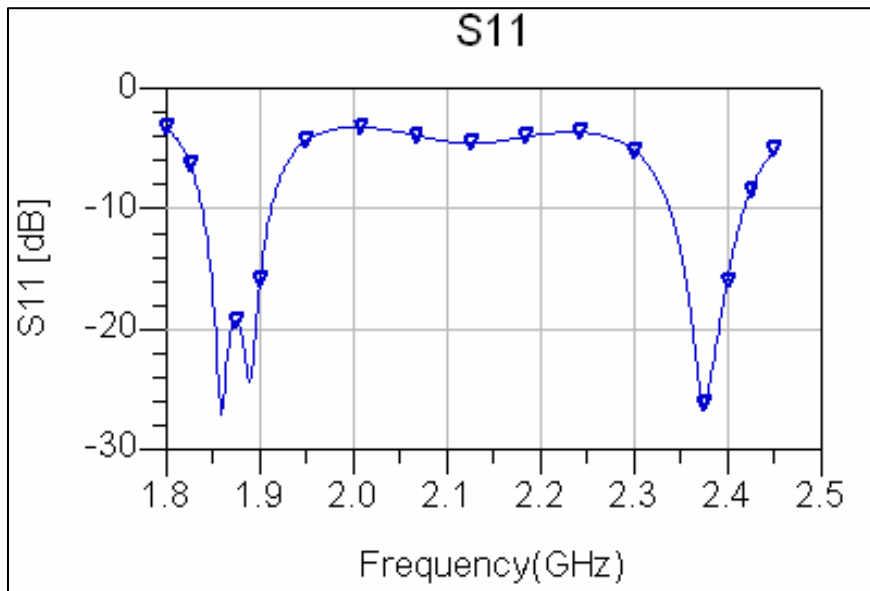

Fig.16 Return loss and impedance bandwidth [7]

From the proceeding, we can conclude that the single patch is very simple in terms of designing, manufacturing, and integrating with other microwave circuitry components. Moreover, it has relatively smaller size in term of the thickness as long as the hand set devices are considered. However, there are other disadvantages that are associated with the single patch that makes the choice of this type of antenna not preferred in certain applications. One of the main disadvantages of the single patch antenna is the relatively small bandwidth of the 3 dB axial ratio. The smaller the bandwidth, the limited application choices of the antenna. The main reason for the smaller bandwidth is the thickness of the substrate, since smaller substrate leaks more current towards the ground plane, and hence the radiated signal is decreased. This problem can be avoided by different means, one of which using multiple antennas as an array where each antenna is radiating CP at a certain desired frequency. On the other hand, other problems associated with array antenna will raise like the cross polarization between the antennas.

4.2 Multiple Patches

Given that the circular polarization can be achieved in many different ways like almost square patch antenna, slots in the patch antenna, double feeding network that feeds the patch antenna, and many other techniques, still the problems associated with the microstrip antennas cannot be neglected or solved by the simple antenna design. Therefore, many other techniques are being studied in order to improve the microstrip antenna performance in terms of the circular polarization axial ratio bandwidth, impedance bandwidth, constant gain level, and lower cross polarizations. One of the main fields of the improving techniques was discussed in the first section where the improvements are implemented on the main designed antenna. On the other hand, other main fields that are being considered in order to overcome the some of the problems associated with the single patch antenna that cannot be solved. One of these fields is the stacked patch antenna, where there is two substrates are being used in order to improve the antenna performance. Using two substrate can improve the antenna performance greatly in term of the operating bandwidth, lower cross polarization, better antenna gain and efficiency [8]. The reason behind this improvement is due to the fact that two different substrates will eventually operate as a material of permittivity that is between the two materials' permittivity called effective permittivity. One of the advantages of this combination is the fact that for lower permittivity substrates it is better to be thick in the antenna design and for higher permittivity substrates it is better to be thinner, hence this combination gives the advantage of using relatively thin designed antenna with better permittivity characteristics. Moreover, the feeding methodology can be improved in this combination since the feeding network can be between the two substrates and

the top patch antenna is coupled to the feeding network. This method of feeding network will reduce the surface waves greatly since there is no direct feed to the patch and hence improving the antenna efficiency [8]. In addition to that advantage, another antenna can be implemented in between the two substrates which will make the antenna perform better than a single patch antenna. For these reasons, stacked patch antennas became a very attractive field for investigations and implementations in many applications. In [9], the principle of the stacked patch antenna is demonstrated where the antenna is designed of two substrates and three conducting materials. Looking at the cross section of the antenna, it consists of a top conductor that will be the patch antenna, then the substrate, ground plane, another substrate, and the feeding line is on the back of the patch antenna. On the top patch antenna, an S-shaped etch is made in order to achieve circular polarization performance [9]. Moreover, it is found that loading the antenna with two slots at the edge of the radiating element will operate the antenna in dual frequency bands. Therefore, the s-shaped slot will result in a dual band circular polarization performance [9].

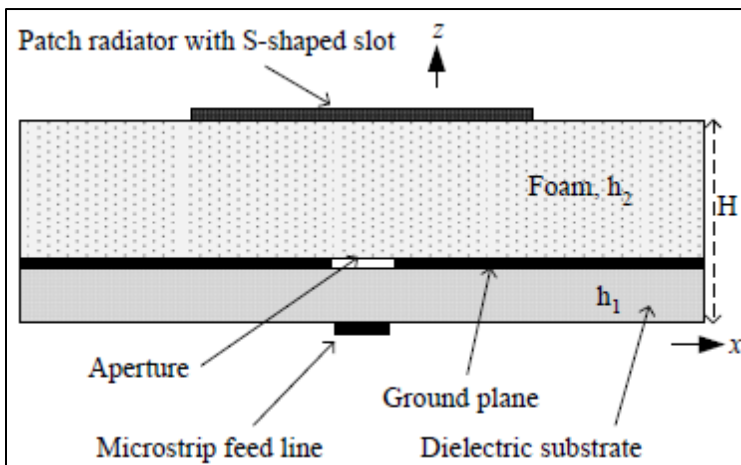

Fig.17 Designed stacked antenna [9]

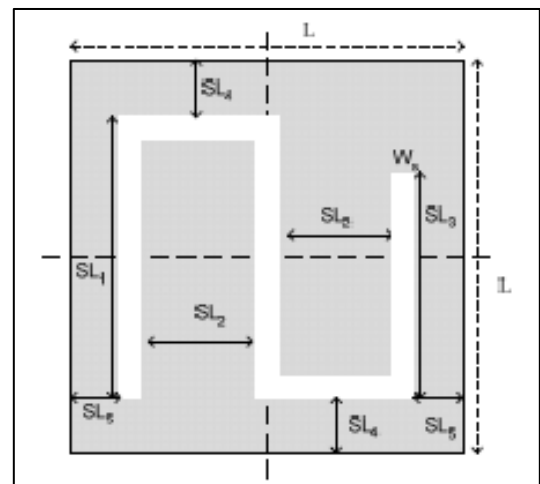

Fig.19 S-Slot patch [9]

OPTIMIZED GEOMETRICAL PARAMETERS			
Parameters	(mm)	Parameters	(mm)
L	38.0	W_s	3.0
G	55.0	SL_1	29.0
S_f	4.75	SL_2	12.75
L_a	30.0	SL_3	23.5
W_a	3.0	SL_4	4.5
H	11.52	SL_5	1.75

Fig.18 Stacked antenna parameters [9]

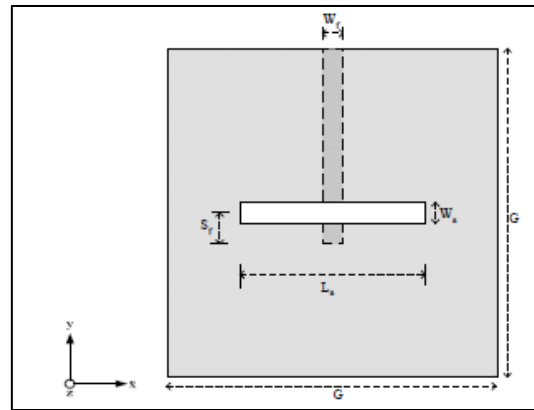

Fig.20 Ground plane [9]

On the ground plane, a rectangular slot is etched in order for the waves to be coupled with the top patch antenna. The advantage of using the coupling feeding methodology is reducing the surface waves on the top of the patch antenna, which is related inversely with the efficiency of the radiated signal, hence improving the efficiency of the antenna. The upper substrate is chosen to be of lower dielectric material to increase the coupling of the patch antenna as shown in Fig.17, Fig.18, Fig.19, Fig.20 [9]. The results of the designed antenna show a good performance in terms of the gain, dual-band circular polarization performance as in Fig.21 and Fig.22 [9]. However, the disadvantage of the proposed is in the narrow bandwidth of performance.

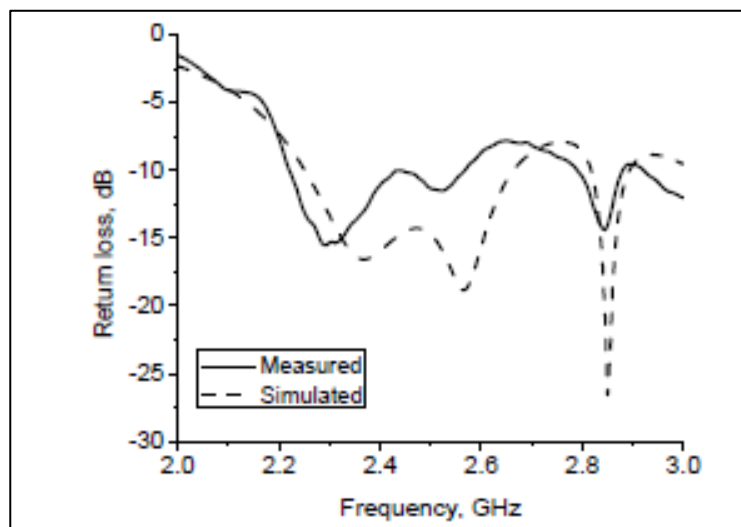

Fig.21 Impedance Bandwidth of the antenna [9]

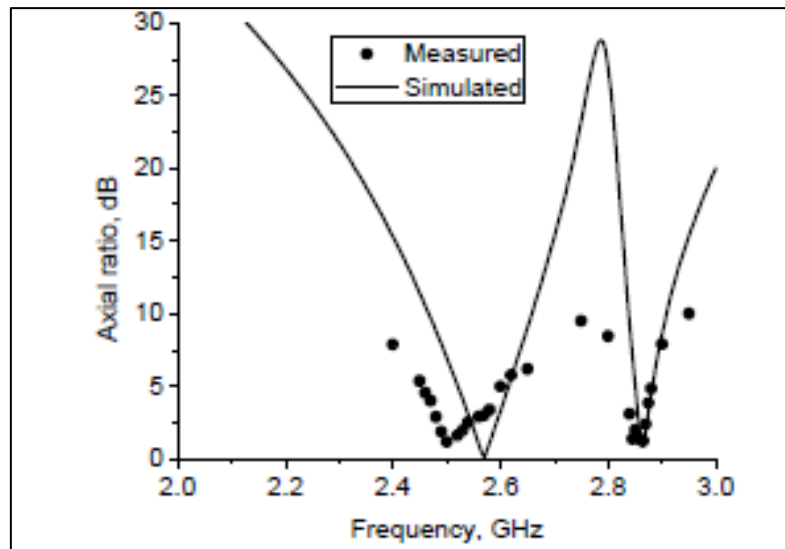

Fig.22 Axial Ratio of the antenna [9]

Similarly, [10] proposes a single feed antenna with stacked patches in order to achieve circular polarization radiation pattern. However, the designed antenna has a different feeding methodology where the coaxial probe is feeding the lower antenna as in the Fig.23, and hence the top patch is coupled with the lower patch [10]. The sizes of the two patches and the location of the feeding point has been optimized in order to achieve the best circular polarization radiation pattern with the highest bandwidth possible. The results of the designed antenna as in Fig.24, shows that AR of 2.5 dB is achieved over more than 13% bandwidth typically acceptable [10].

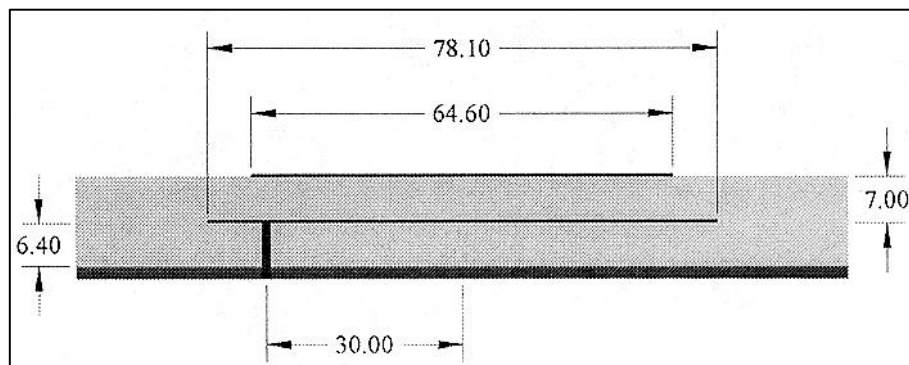

Fig. 23 Dimensions of the designed antenna [10]

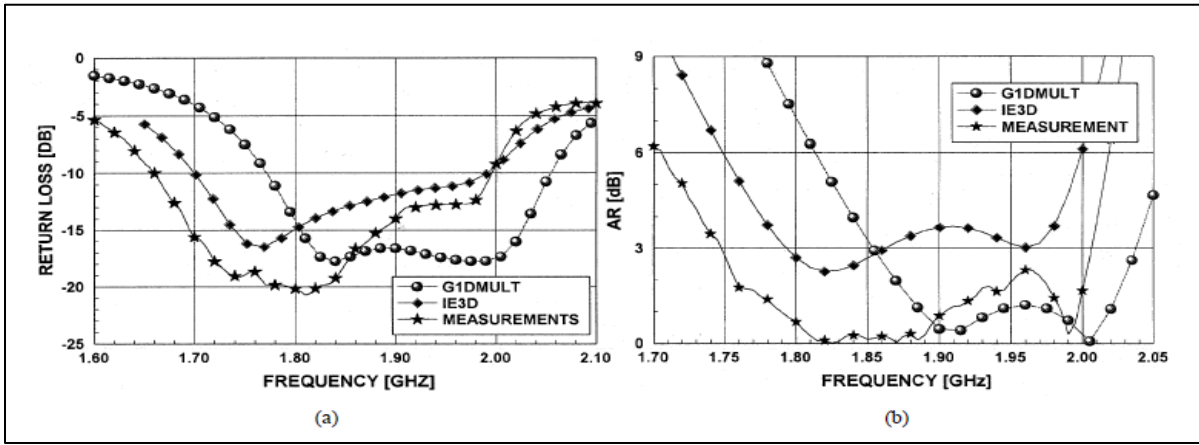

Fig.24 Obtained results of the proposed antenna [10]

Likewise, two works as in [11] and [12] proposes to use three substrates with the designed antenna. The third material that has been added which is having relatively lower permittivity. However, the location of the feeding point and the order of the layers are different in the two designs as it is shown in Fig.25, and Fig.26 [11], [12]. Both antennas have been designed by optimization where the location of feeding point and the thickness of the substrates have been optimized in order to achieve the best antenna performance.

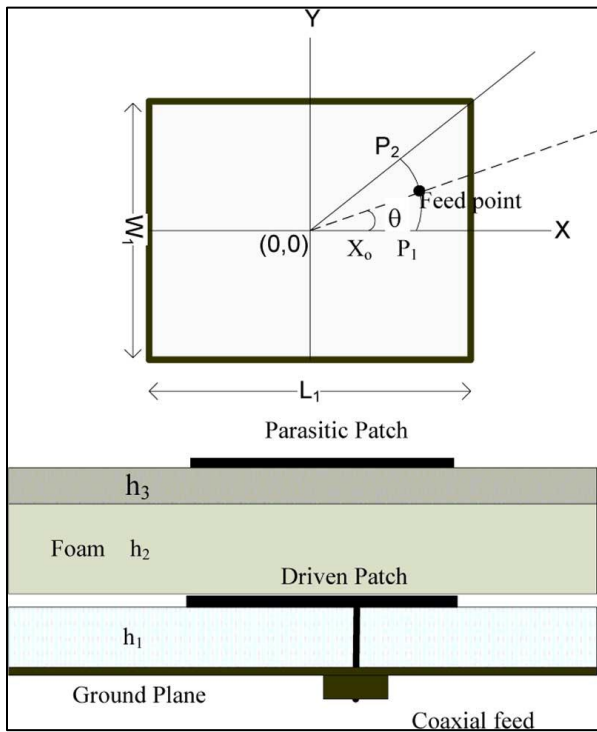

Fig.25 Antenna structure of the work in [11]

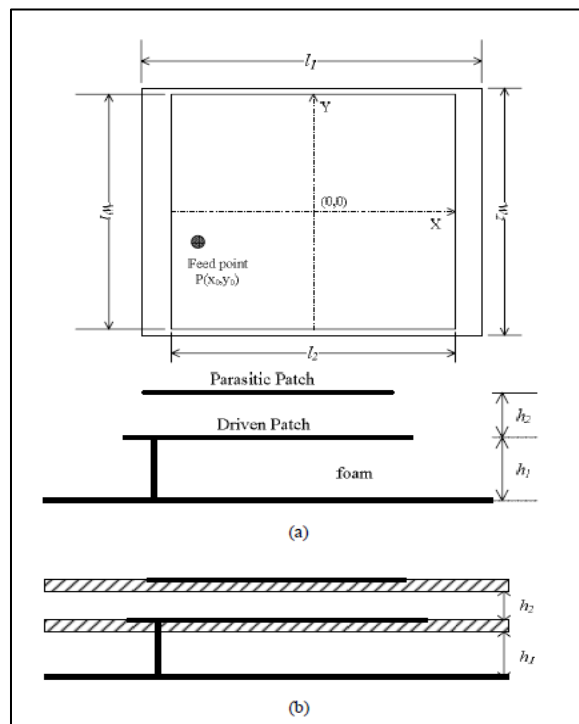

Fig.26 Antenna structure of the work in [12]

The results of the designed two antennas, proves the validity of the concept, where the antenna operates at a relatively high bandwidth as in Fig.27 [12].

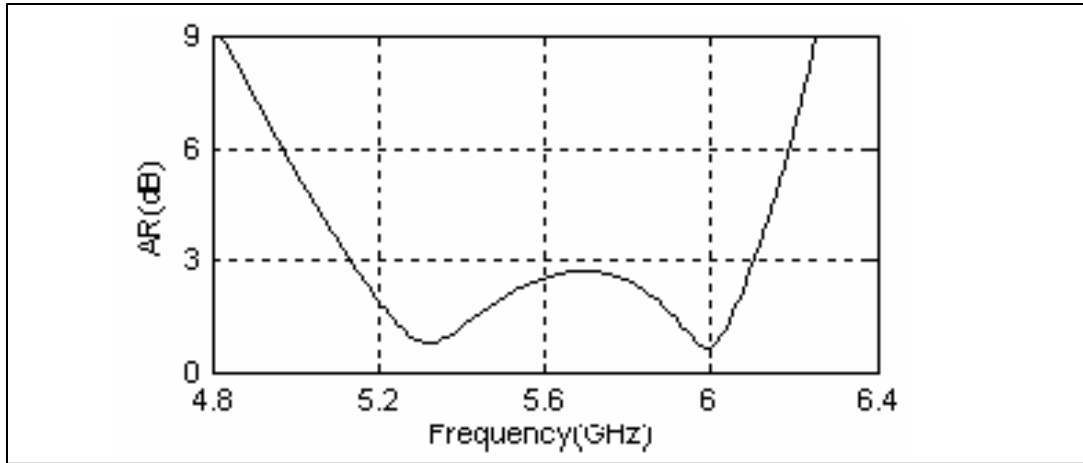

Fig.27 The Axial Ratio bandwidth of the antenna [12]

The principle of the stacked patch antenna can be extended to a wider range of different designs and antenna configurations. One of the examples is using more than two patches and a ground, in which multiple layers of substrates and patches are used. This could have been used in order to operate the antenna in more than one band, or to improve the antenna performance in a certain band. Reference to the work in [13], the author designed an antenna that consists of three patches, ground plane, four substrates, and a feeding network. The proposed design is intended to operate at three different bandwidths with a circular polarization. The feeding methodology is a dual feed network which is easier in obtaining circular polarization for a conventional antenna patch design [13]. Feeding each patch is designed to be through a metal via hole that passes through the other patches as in Fig.28 [13]. The reason behind this feeding method is to make the other patches to operate as a ground plane when one patch is excited or at a certain frequency band.

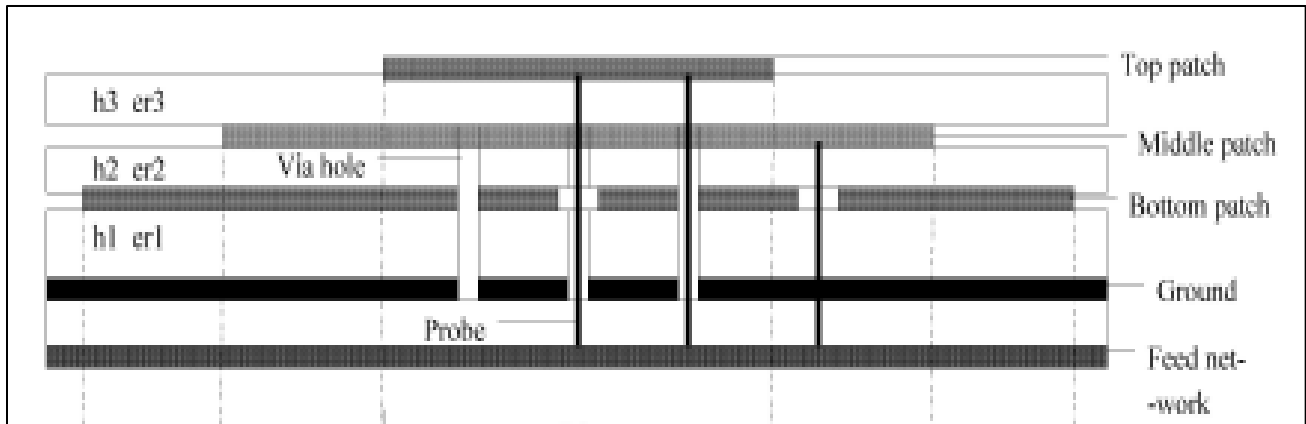

Fig.28 Proposed patch antenna with multiple patches [13]

In the same context, where different configurations can be used with the stacked patch antennas, the simple stacked patch antenna of two substrates and three conducting material can be used as simple as a feeding network, ground plane, and a patch surface. This principle will give a degree freedom to the antenna in designing the feeding network, either single or dual feeding, that will have the best radiation characteristics and matching with the antenna input impedance.

Moreover, segregation between the feeding and the patch will reduce the cross polarization of the antenna, hence better radiation efficiency. This method was presented in the work of [14], where the lower surface was used in order to feed the patch, the middle part as a ground plane, and the top as the antenna patch. In [14], two half – annular ring patch was used as the antenna patch as in Fig.29 [14]. According to the author, the annular ring has several advantages over the conventional circular or square patches since it has a smaller size comparing to a circular patch for a given frequency [14]. Moreover, it can be used to combine other surface structures in order to operate the antenna is a dual band, the modes can be separated by the ratio of the outer radii to the inner radii, and wider bandwidths can be achieved comparing to the circular patches [14].

The feeding is through a single feeding Transmission line that is modified in order to achieve the best matching with the input impedance of the antenna. In order to feed the patch antenna, a cross slot is etched in ground plane in order for the signal to be coupled to the upper patch and

hence the patch radiates [14]. Moreover, the cross slot is the main component that will generate the CP that is by generating two orthogonal degenerate modes with equal magnitude and 90° phase shift. Other than that, the thickness of the substrate plays a major role in the antenna performance.

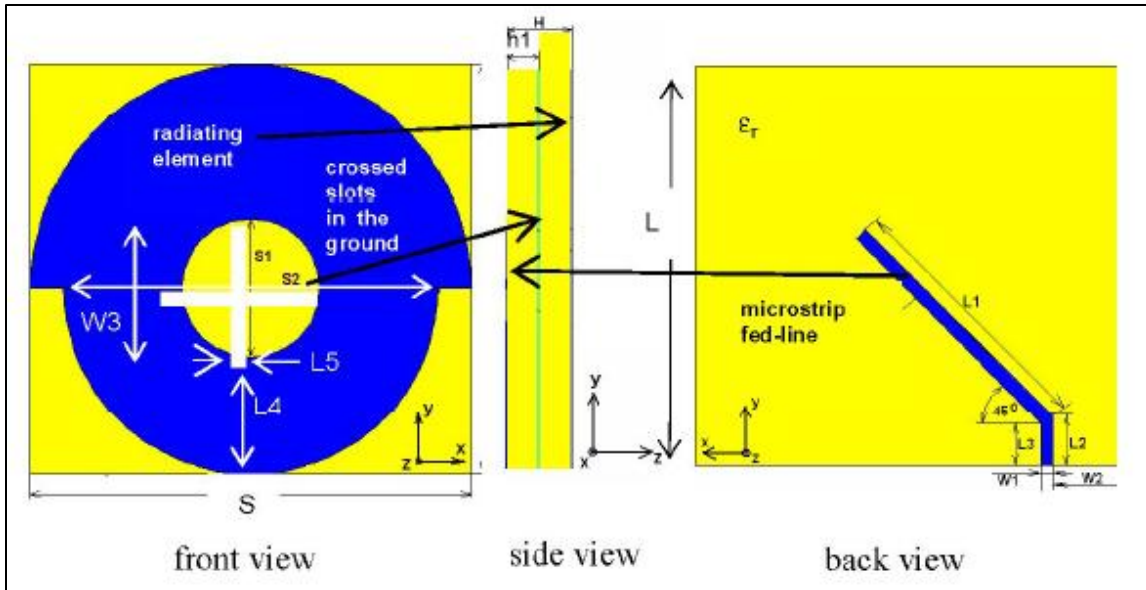

Fig.29 Two half annular ring antenna [14]

Parameter	[mm]	$[\lambda]$	Parameter	[mm]	$[\lambda]$
H	1,574	0,008	L4	14,7	0,079
L	55,5	0,3	L5	1	0,005
S	59,6	0,322	S1	20	0,108
h1	0,787	0,004	S2	51,4	0,28
L1	28,8	0,21	W1	2	0,01
L2	6	0,032	W2	9,6	0,052
L3	4,6	0,025	W3	22	0,119

Note:
The electrical dimensions in table correspond to frequency $f_r=1.621$ GHz

Fig.30 Dimensions of the proposed antenna [14]

The higher the thickness of the substrate, the better antenna performance in terms of the Bandwidth, and radiation efficiency. However, the 50 ohm matching would be difficult to achieve with the higher thickness substrates [14]. The results of the designed antenna shows a great matching between the concept and the implementation. However, the bandwidth of the designed antenna is relatively small for mobile communication applications as in Fig.31 [14].

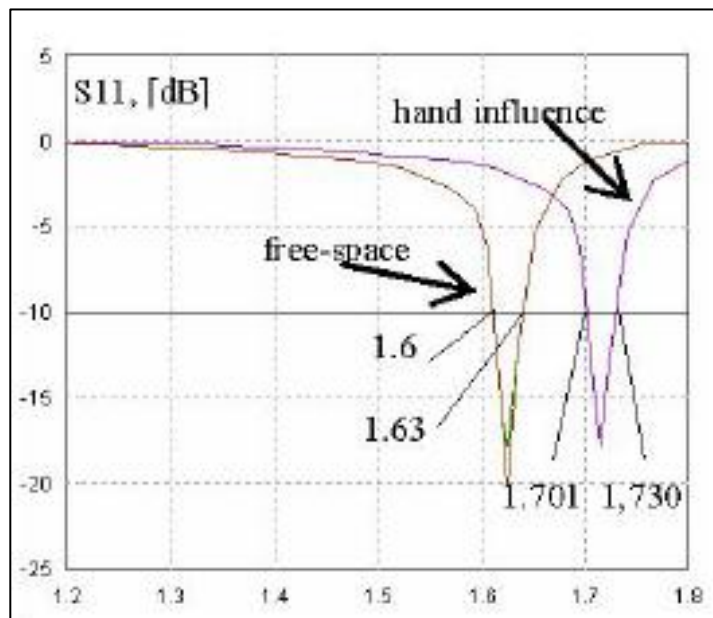

Fig.31 Antenna impedance BW [14]

Despite the relatively small bandwidth, the proposed antenna is compact, easy to manufacture, analyze, and simple in obtaining circular polarization pattern. On the other hand, the work in [15] proposes a different concept to be implemented on patch antennas. The principle is modulating other antennas and implement it on a patch antenna. As a result, a combination of proximity coupled circular microstrip antenna and a square quasi-planar surface mounted short horn is proposed [15]. The proposed antenna consists mainly of a simple patch antenna of two substrates and three different layers of conductors where one as a ground plane, and the other two as a feeding network and a patch antenna. Moreover, a square quasi-planar surface mounted short

horn is added to that combination for the purpose of improving the antenna gain as in Fig.32 [15]. The patch antenna is a circular patch antenna with a cross slot that is to obtain circular polarization.

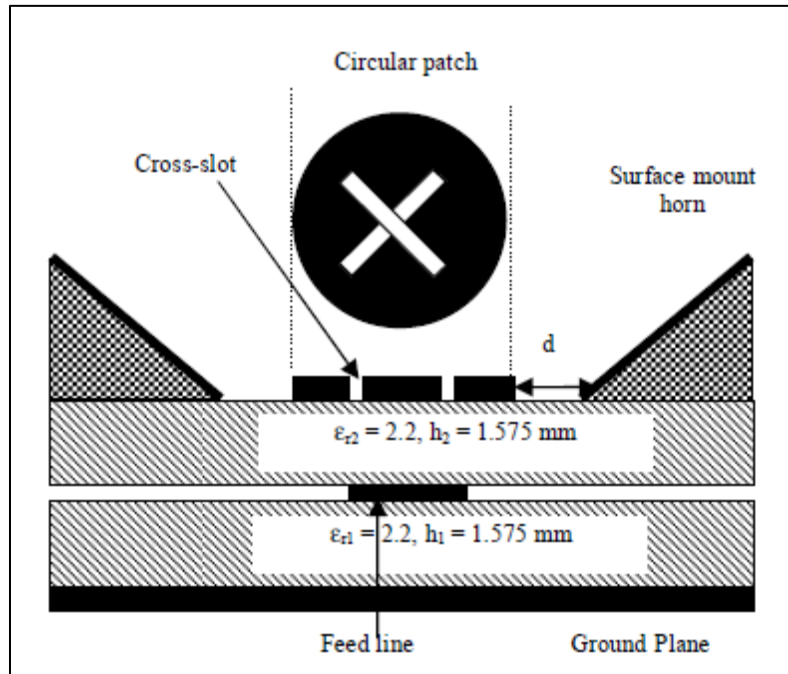

Fig.32 Structure of the proposed antenna in the work [15]

The lengths and the widths of the cross slots is designed in order to obtain the best circular polarization performance. The feeding to the circular patch is through the coupling of the feeding network. However, the feeding to the surface mounted horn is through the mechanism of the surface wave mode on the dielectric interface. The antenna performance shows great results in terms of the gain and the impedance bandwidth as in Fig.33, 34 [15]. On the other hand, the axial ratio of the antenna, which is the main parameter for measuring the antenna performance as a circular polarization antenna, is greatly affected by the presence of the surface mounted horn.

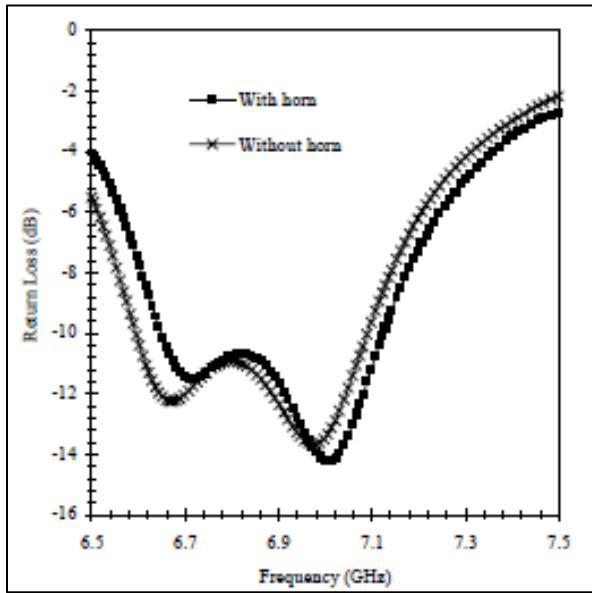

Fig.33 Proposed antenna impedance BW [15]

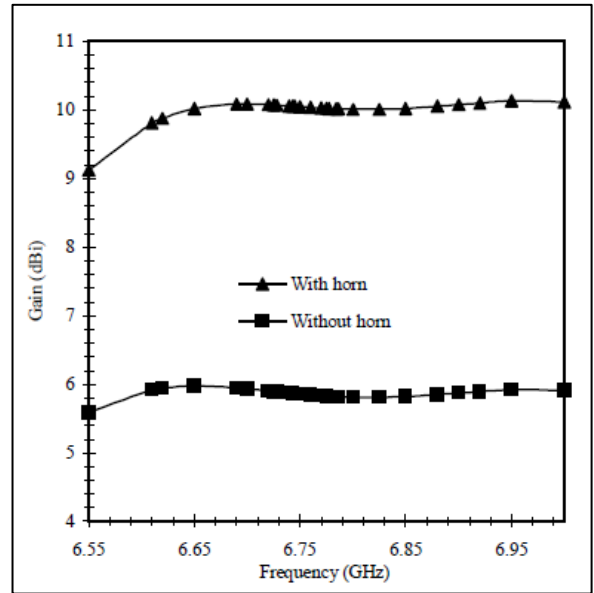

Fig.34 Proposed antenna gain [15]

From the proceedings, it is found that the stacked patch antennas are of great value in designing compact patch antennas. In addition, it provides a variety of design options and mechanisms. The stacked patch antennas allow for different feeding methodologies like the coupling where it enhances the antenna performance since it reduces the cross polarization level of the antenna comparing to direct feed through transmission lines. Although stacked patch antenna provides various advantages over the single patch antenna, the single patch antenna has the advantage in terms of the antenna size taking in consideration the thickness of the patch. In mobile communication systems, the size of the antenna is very critical, where the single patch antenna is preferable given the dimensions of the antennas. In addition, the antenna profile, compactness, and manufacturing and mounting is easier with single patch antennas comparing to stacked patch antennas.

4.3 Multiple Patches with air gap

As long as multiple patches option is considered as previously discussed, another concept was introduced which is using air gap as a dielectric material in the design of the patches. This concept was mainly introduced in order to benefit from the characteristics of the air since it has the lowest relative permittivity. Air gap will help in reducing the effective permittivity of the overall dielectric materials that are being used in the design. As a result, a relative symmetrical medium is achieved surrounding the patch from top and bottom, but that is impossible to achieve taking in consideration the other material and the ground plane. However, the lower the relative permittivity will result in a better antenna performance since it will increase the radiation efficiency, widening the operating impedance bandwidth, and the overall antenna characteristics. However, some challenges will rise as the air gap is introduced such as the stability of the antenna, the manufacturing difficulty, and the effect of the rise of antenna temperature. The following section will discuss some of the designed antennas with air gap. In the work [16], a circular polarization radiation antenna was designed by using the concept of the truncated corners on a square patch antenna. “Two symmetric truncated corners on the radiating material will make the square patch to radiate in circular polarization”, stated in the work [16]. Choosing the location of the feeding, will determine the location of the truncated corners as choosing different locations will eventually result in different orientation of the circular polarization between RHCP and LHCP as in Fig.35 and Fig.36 [16]. After designing the single patch antenna that will radiate the circular polarization radiation, the concept of the air gap was introduced to enhance the antenna performance. The height of the air gap will have a major impact in the

overall performance of the antenna as it will affect in the effective permittivity of the patch and hence the gain, impedance bandwidth, and AR bandwidth.

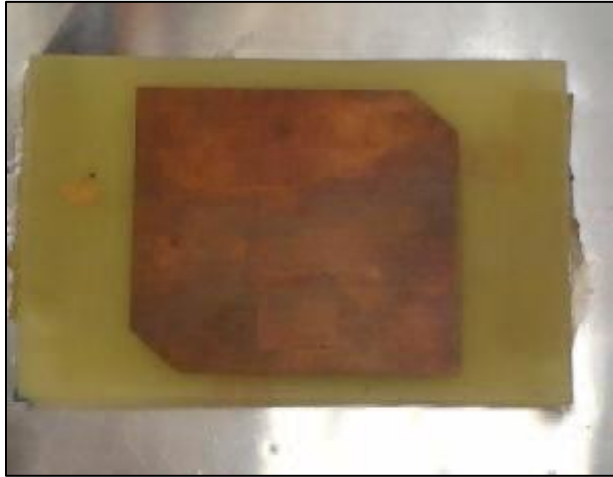

Fig.35 LHCP with Coaxial Feed [16]

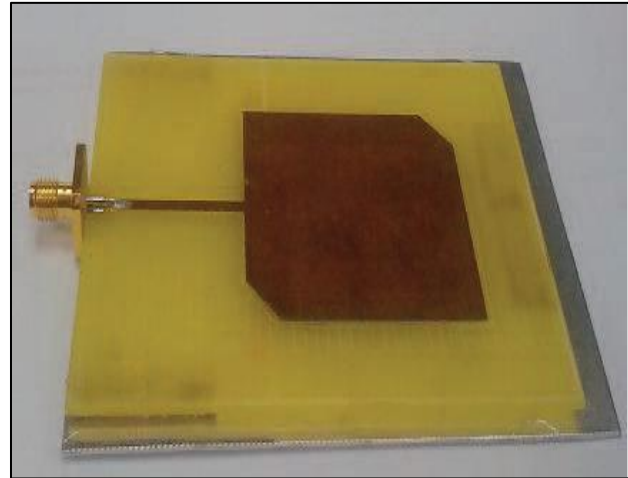

Fig.36 RHCP with side TL Feed [16]

The antenna was designed and simulated in order to study the results and the impact of the concept of air gap on a patch antenna as a dielectric material. The feeding methodology was chosen to be through Transmission Line. Moreover, the TL was designed in steps in order to match the antenna input impedance to the TL impedance, and hence reducing input reflection coefficient as in Fig.37 [16]. The simulated results shows a great enhancement in the antenna performance in term of the 3 dB AR bandwidth, which shows as almost 300 MHz bandwidth as in Fig.39 [16].

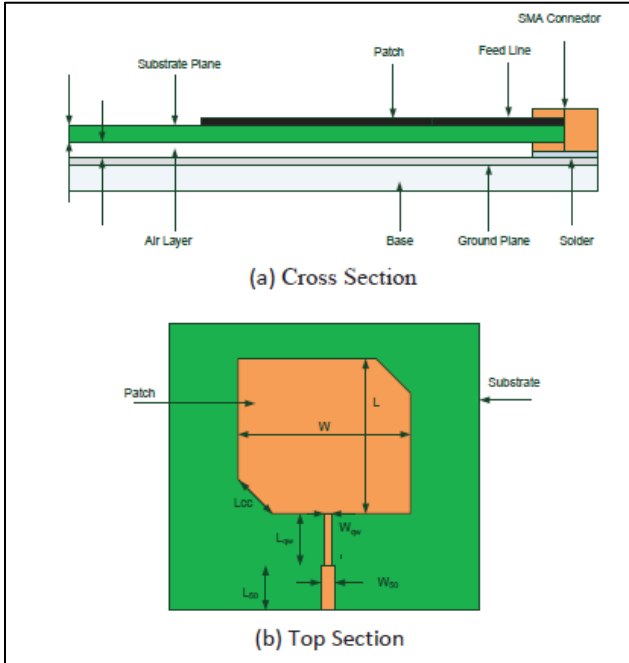

Fig.37 Antenna design in the work [16]

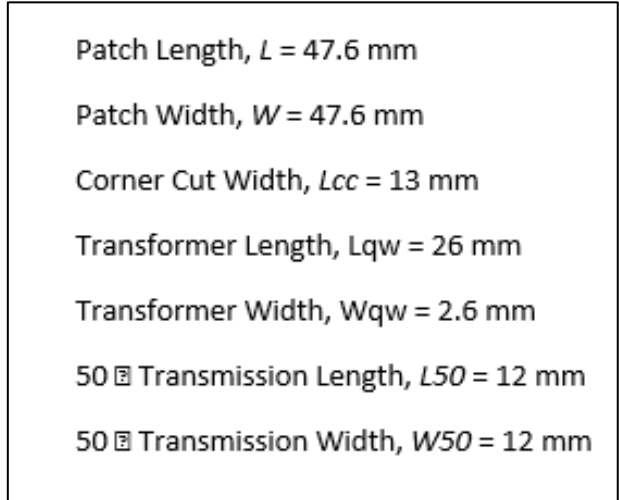

Fig.38 Antenna design parameter of the work [16]

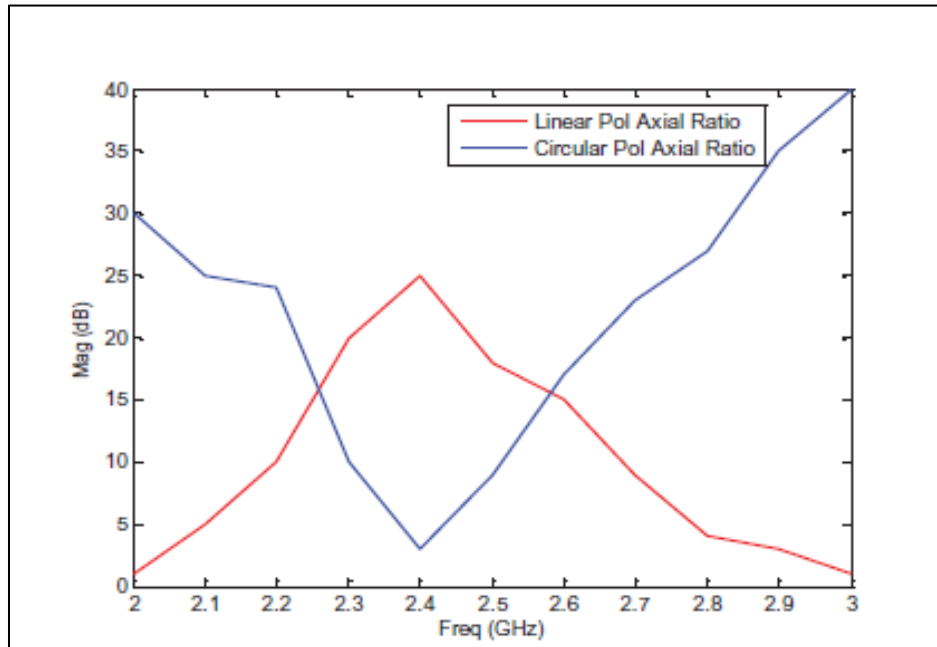

Fig.39 CP AR bandwidth of the antenna in the work [16]

Another work [17] discusses the use of the air gap in the designing of a satellite communication microstrip antenna. The method to achieve the circular polarization in the designed antenna is to use a cross slot on the patch. The lengths or the ratio of the length of the

two slots will determine the radiation pattern as well as the location of the feed point. Then, use the principle of electromechanically coupled antenna in order to feed the antenna through the cross slot. Using cross slot will reduce the antenna operate the designed antenna at higher frequency which means reducing the antenna size [17]. After that, in order to enhance the performance of the antenna an air gap was introduced in order to increase the operating bandwidth of the antenna as in Fig.40 [17]. Moreover, the bandwidth of the antenna increase as the antenna substrate increase, but increasing antenna's substrate height will affect the compactness of the antenna. The simulated of designed antenna shows a great agreement between the concept and the results. On the other hand, the author is indicating that using U-shaped slot on the patch antenna will enhance the bandwidth greatly and will introduce a capacitive component tot the antenna which will reduce the imaginary input impedance of the antenna since the inductive part is introduced by the feeding probe and hence relatively easier matching [17].

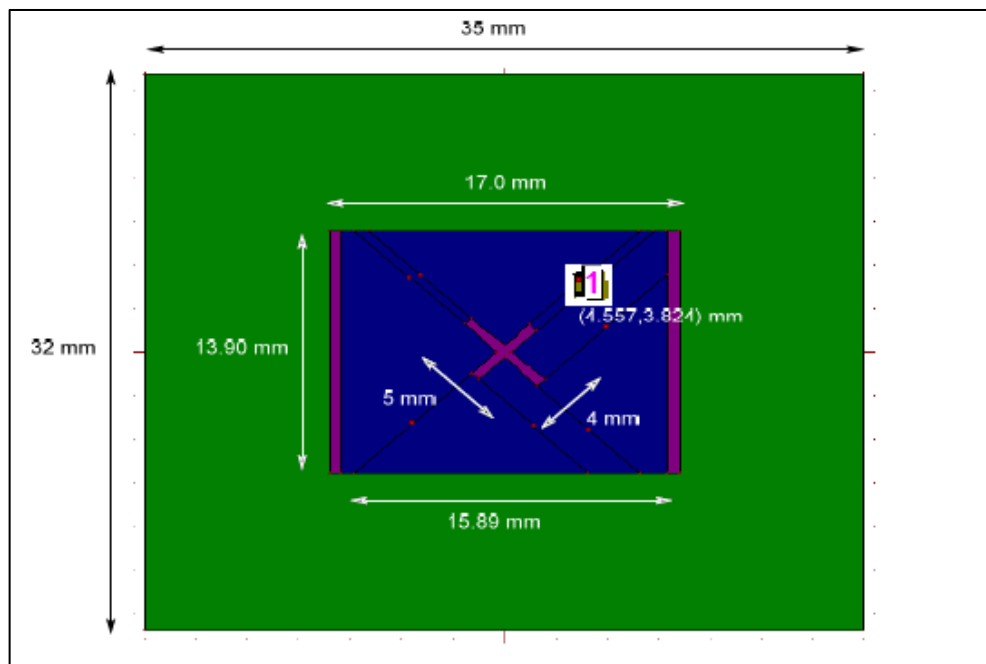

Fig.40 Antenna design with cross slots of the work [17]

In line with the proceeding research, the work of [18] proposed another solution for satellite communication, which is the use of the sequential rotation. This solution is practical and easy to be manufactured for larger sized communication components, not the handset devices. As it can be seen in Fig.41, the method of achieving CP is through the dual-feed, since each feeding Transmission Line will operate at a certain mode. Moreover, an air gap is used and the patch is fed by the concept of electromechanically coupled patch. The antenna consists of two substrates on top of each there is a patch and between the two substrate is the air gap. Therefore, TL will be feeding the lower patch which will feed the upper patch by the concept of the electromechanically coupled patch as in Fig.41 [18]. In addition, since the main goal of the research is to overcome the drawbacks of CP antennas as the low gain over the entire impedance and AR bandwidths, an array is proposed for this design. The array consists of 16 patches or as it is considered 4 x 4 array where each patch will be fed by two TL for the CP radiation as in Fig.42 [18].

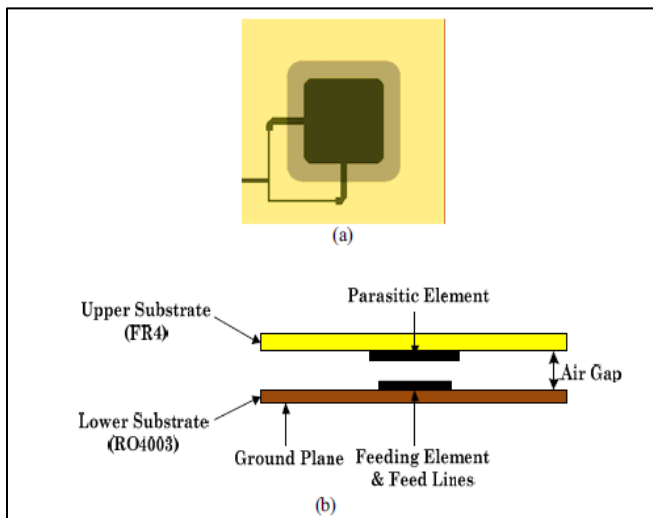

Fig.41 Single patch of the designed array
by the work in [18]

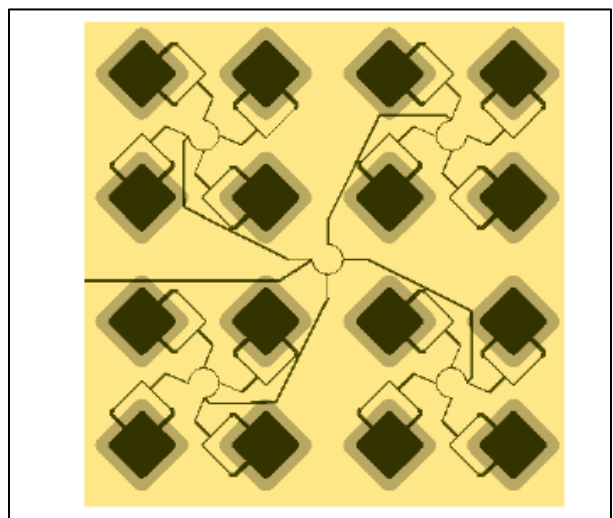

Fig.42. The design of the proposed array
by the work in [18]

As long as the arrays are considered, the coupling effect has to be taken in consideration. As a result, the designed feeding TL has to be as narrow as possible and high characteristic impedance in order to reduce the effect of the spurious radiation and the coupling effect [18]. The results of the designed array as in Fig.43 shows a great performance in terms of the impedance bandwidth which is greater than 25%, AR bandwidth which is around 15%, and as high gain as 14 dBi [18]. However, the size of the designed array, and the complexity of manufacturing are the major drawbacks of the designed array.

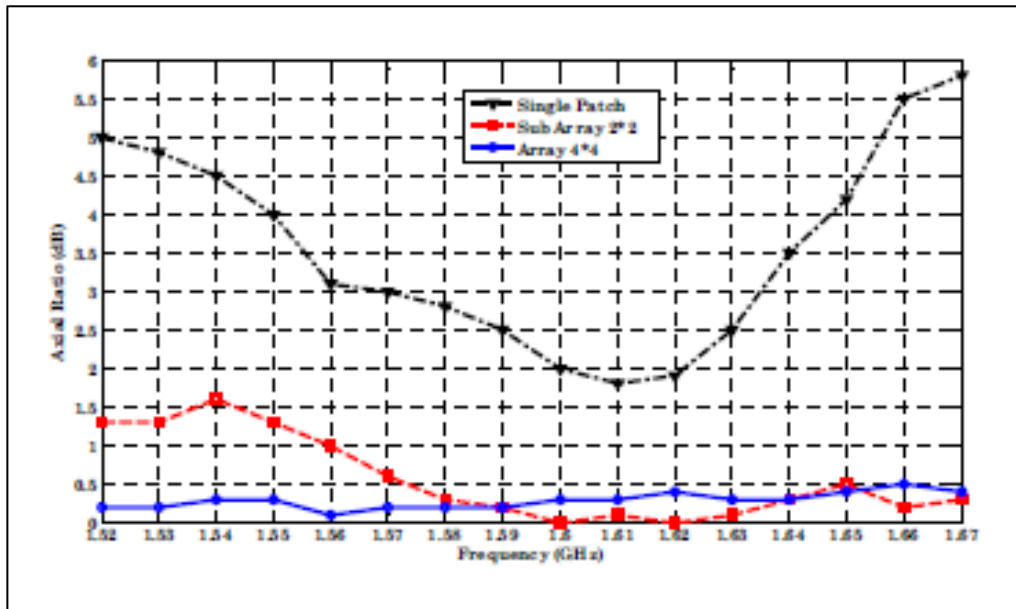

Fig.43 Axial Ratio bandwidth of the designed array [18]

Furthermore, other researchers have been proposing other solutions that will include the use of the air gap. In work of [19], a compact microstrip antenna design is proposed where the patch is designed to be a rectangular ring. The antenna is composed of two rectangular rings each is etched on top of a substrate of relative permittivity of 2.55. The two antennas are separated by an air gap and a conductor is connected through the ground plane to the upper patch as in Fig.44 [19].

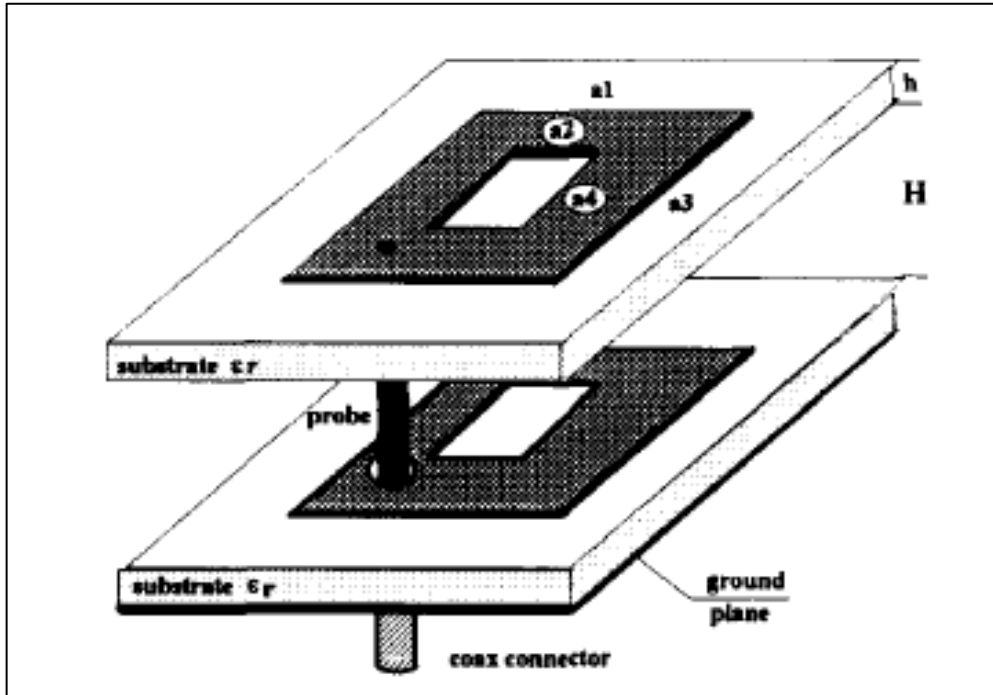

Fig.44 The proposed antenna in the work [19]

Therefore, the upper patch is electrically connected to the feed point while the lower patch is coupled with the upper patch. This method is proposed in order to enhance the performance of the antenna in terms of the CP bandwidth and multiple frequency operation. On the other hand, the work in [20] suggests that only a patch antenna and a ground plane with an air gap between them can be used as an antenna. However, since the hazardous environments have to be taken in consideration, and also the stability of the patch, a thin substrate layer is proposed to below the conducting patch as in Fig.45 [20]. In addition, six conductor spacers are used to support the patch conductor. These conductors will cause a change in the input impedance characteristics of the antenna, and hence make it difficult to match the input impedance to the feeding line [20].

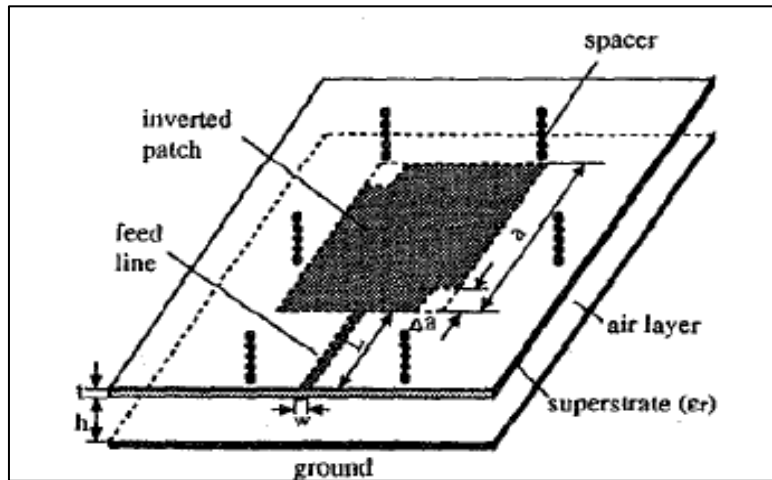

Fig.45 The proposed antenna with thin substrate in the work [20]

As it can be seen from the proceedings, that air gap is very useful tool in terms of enhancing the performance of the designed antenna. Still achieving the CP has to go through the conventional methods where dual feeding, of single feed with modification to the patch antenna to produce two degenerate mode with same magnitude and 90 degrees phase difference. Air gap is very useful in terms of enhancing the bandwidth of the antenna which means both axial ration bandwidth and impedance bandwidth. Moreover it increases the gain, radiation efficiency of the antenna, since the effective permittivity of the substrate will be decreased and hence increase the radiated power. These features makes the air gap very attractive in terms of the research and implementations. However, there are other drawbacks of using air gap in the practical antennas especially for the hand held devices and small mobile devices. The first thing is the difficulty in the manufacturing since the air gap has to be held by supports, where these supports will affect the designed antenna performance since it will contribute to the overall antenna design. Secondly, air temperature will change the characteristics of the air gap, same as other materials, but these changes may have significant effect on the antenna performance which may lead to different undesired results.

4.4 Antenna performance enhancements techniques

In this section, we are exploring different ideas and methods that are used to enhance the antenna performance. The main idea is to understand different methods that can be used later on, after designing the antenna, in order to enhance the designed antenna performance. In this regards, that mainly aims to enhance the antenna performance in terms of the band width of the return loss, antenna size, gain of the antenna, Circular polarization band width of the antenna, radiation pattern of the antennas, and the matching between the antenna and the feeding mechanism. In the work [21], the author is proposing to utilize the various advantages of using hybrid feeding to the antenna like the wider Circular Polarization Band width by using a simple single feeding mechanism. This is done by adopting a series feeding to the antenna by utilizing only one feeding transmission line as in Fig.46. Four feeding arms are placed behind the cross aperture in order for each arm to create quarter wavelength in which each are 90 degrees phase difference to the other section and hence CP behavior of the antenna is obtained [21].

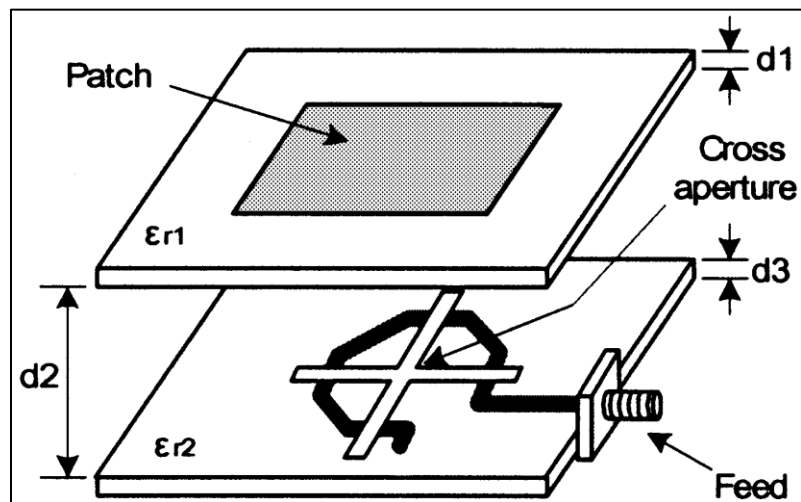

Fig.46, Antenna design considering single feed of the work [21]

The antenna performance enhanced, in term of, the antenna gain over the band width, and CP band width. However, the main disadvantage of this design is the complexity of the antenna in terms of the manufacturing aspects.

In line with work of [21], the author in the work [22] is proposing to keep the differential feeds, but to modify the method that is designed for the differential feeding. The differential feeding is done through two parallel plates fed from a pair of probes as in Fig.47 [22]. The two plates will act as two feeding lines to generate two degenerate orthogonal modes for the CP radiation pattern [22]. The power divider of the two plates is designed by using Wilkinson Balun with Micro-strip Meta-Material. On the other hand and as per the work [21], the main disadvantage of the antenna is the bulky design. The antenna size and the complexity of the design make it difficult to be adopted specially for small hand holding devices as what is targeted in this research.

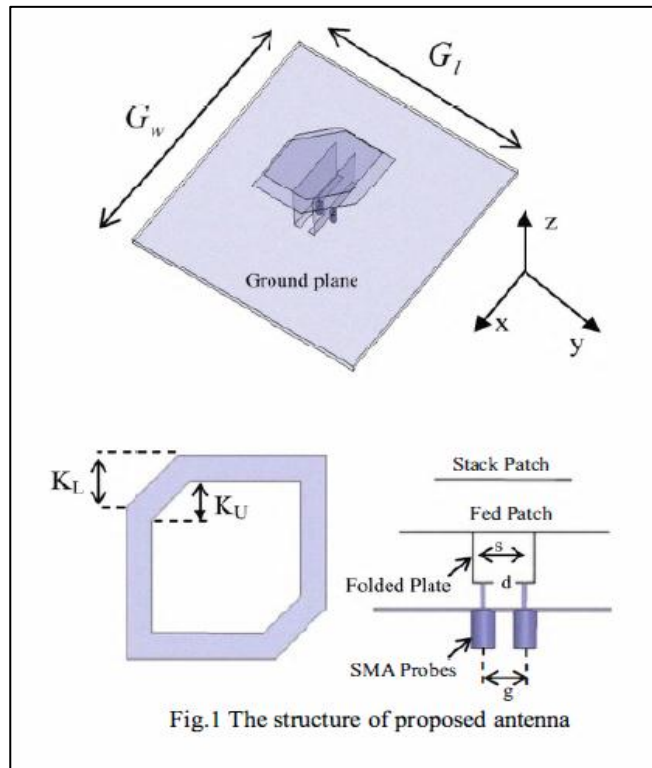

Fig.47, Antenna design with differential plates feeding by the work [22]

In line with the proceeding presented researches, [23] work's author is suggesting to use the concept of the almost square antenna for the CP radiation pattern. However, almost square patch antenna have been known for the CP radiations, the author is proposing to enhance the performance through the multiple substrates layers. In the work [23], three substrates layer where uses, two of the same material and in between an air gap. The antenna output showed great increase in the CP Band. Since the feeding point was designed for the maximum CP BW that can be achieved, the matching of the antenna BW was affected greatly [23]. Fig.48 shows the antenna dimensions and design which achieved CP BW over 150 MHz from almost 1.85 GHz to over 2.00 GHz [23].

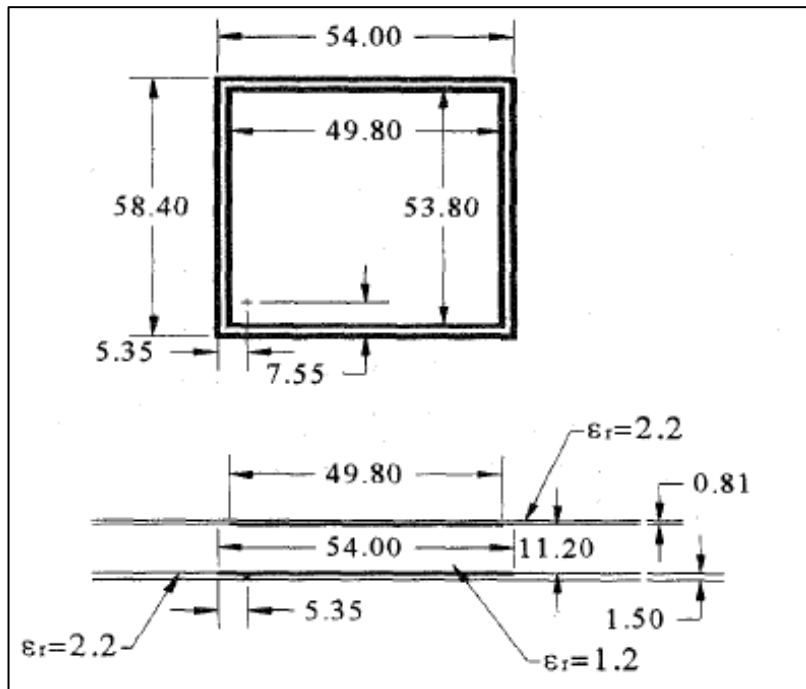

Fig.48, Antenna design and dimensions [23]

Taking in consideration the previous methods and techniques that have been introduced to enhance the CP BW, Radiation pattern, or antenna performance, there are other techniques which have been introduced and tested to enhance the design of the antenna and the Matching

BW of the antenna. In following works [24], [25], and [26], modifications to the antenna patch or the ground patch is explored in order to improve the antenna design and the return loss of the antenna. In [24] the idea of the fractal patch antenna is presented. Fractal patch antennas help in reducing the size of the antenna in a huge was taking in consideration that the antenna of any communication system is usually the largest component. Therefore, reducing the patch antenna size helps in making the antenna more compact to its applications. In this paper, the fractal of E-shaped is implemented at the edges of the patch antenna. Iterations of the E-shaped fractal reduce the antenna size and improving the matching, but not the band width of the antenna which is not affected by the fractal effect [24]. Fig.49 shows the antenna shape and design considering the E-shape fractal with different iterations [24]. “Exploitation of E-shape fractal notion in antenna design makes the patch antenna flexible in terms of generating resonances and BW as an iteration order of the fractal is increased” [24].

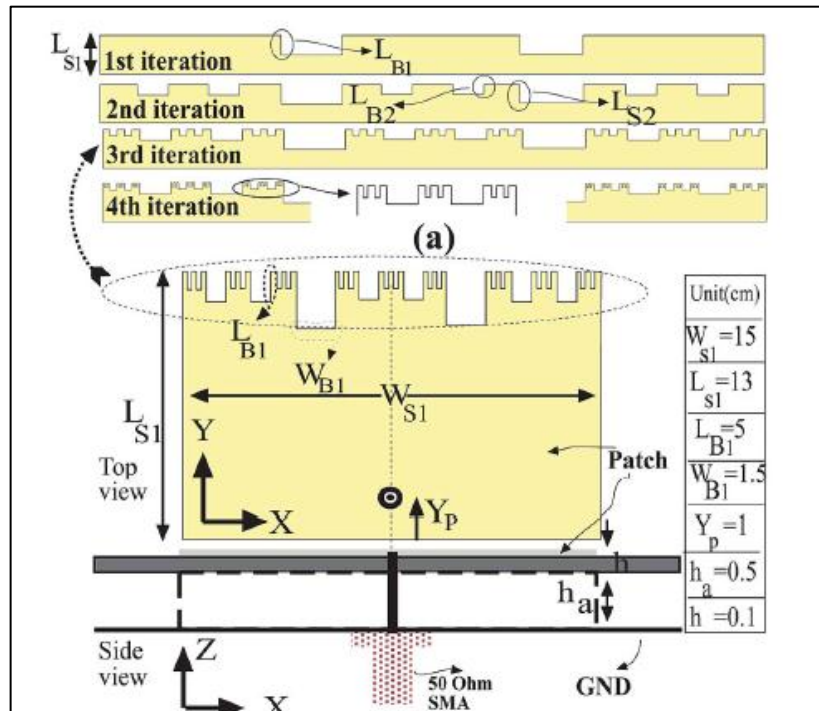

Fig.49, Antenna design with fractal E-shaped [24]

Moreover, in [25] and [26], the idea of the DGS has been investigated. Defective Ground Structure can be used in order to improve and reduce the antenna size. It is considered a unique way of reducing the antenna size by etching the ground plane. In the work [25], by varying the size of the defect, its location and shape the desired resonance frequency can be obtained. In addition, the DGS can be used in increasing the efficiency of the antenna, reducing the cross polarization, mutual coupling reduction, and suppression of higher order harmonics [25]. Furthermore, in [25] cavity backed structure has been used in order to avoid surface wave propagation and hence increasing the efficiency of the antenna. Fig.50 represents the antenna with the DGS and the cavity structure of the antenna [25]. Similarly, in the work [26] DGS has been used in order to improve the properties of the designed antenna. However, in [26] the antenna is an array antenna with two patches next to each other. Three DGS have been used in order to improve the antenna size and reduce the mutual coupling between the two antennas [26]. Two DGSs have been used underneath the for the antenna size reduction. However, “the rectangular head dumbbell shaped DGS suppress the surface wave of the antenna elements when the frequency of the antenna elements matches with the resonance frequency given by the rectangular head dumbbell shaped DGS” as in Fig.51 [26]. Therefore, from the proceedings, there are couples of methods that can be used in the patch antenna itself either the radiating patch or the ground patch for enhancing the antenna performance. The antenna performance can be enhanced based on the desired outcomes of the antenna itself. Mainly, the reduction of the antenna size which can improve the antenna compactness for the hand held devices and small devices can dramatically be improved. Other reasons which are related to the suppression of the surface current which is related directly with the mutual coupling especially for the array

antennas can be reduced. Moreover, the reduction of the mutual coupling of the antenna and increasing the antenna matching in the BW of operations can be improved.

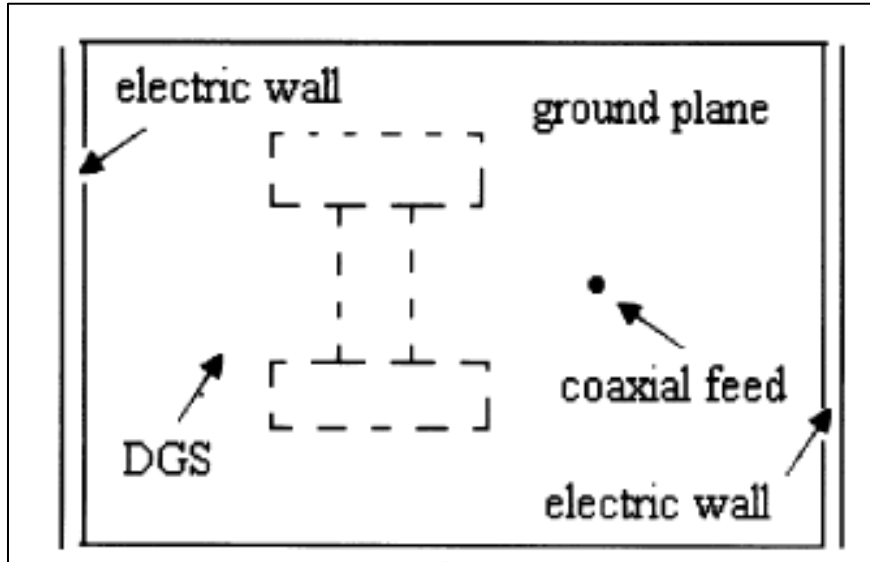

Fig.50, Antenna with DGS and Cavity Structure [25]

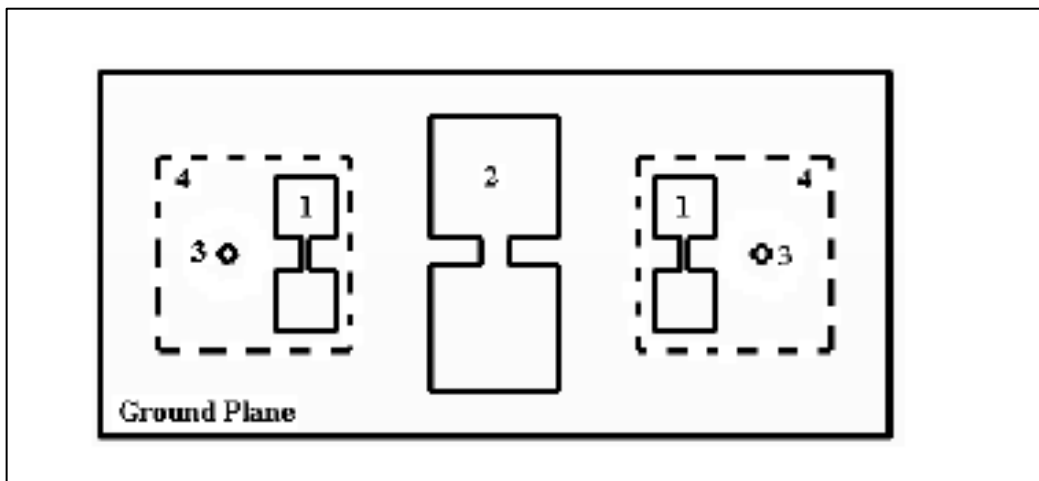

Fig.51, Array Antenna with three DGSs [26]

In addition to what have been presented earlier as methods of improving the antenna performance, the author of the work [27] investigated new methods to improve the antenna parameters. In the work [27], the antenna is composed of patch antenna with cross slots on the

patch and also a surface mounted short horn SMSH. The main reason for the use of the SMSH is to enhance the gain of the antenna [27]. On the other hand, it affects the antenna performance in term of the AR and its BW. Therefore, once the SMSH is designed or integrated on the antenna after the patch design is completed and then a fine tuning to the patch must be done in order to retain the performance of the antenna in term of the BW and the AR [27]. “The patch act as a feed to the surface mounted short horn SMSH through the surface wave on the substrate and radiation from the patch/dielectric radiator, thus, MS antenna on a high dielectric substrate can be used for more gain enhancement by integrating quasi-planar SMAH configuration because stronger surface wave excited on the high dielectric constant substrate” [27]. The cross slots on the patch antenna with different lengths and widths are being used in order to radiate CP radiation pattern of the antenna as shown in Fig.52 [27].

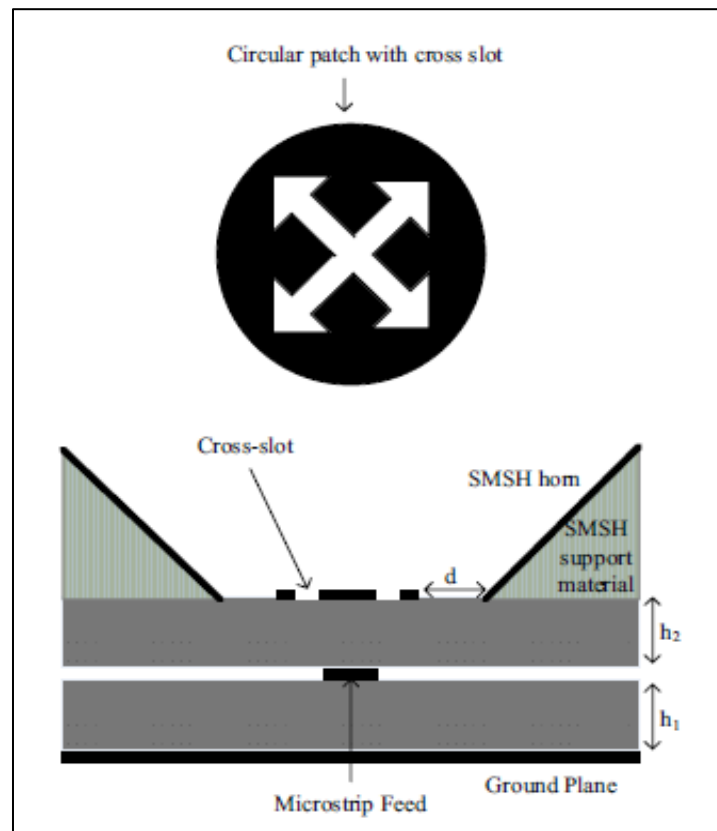

Fig.52, Antenna design with Cross slots and SMSH [27]

Based on the above, and as given in the literature review, different techniques and methods were used in order to develop our proposed antenna. Moreover, the following chapter will present the Simulator Software that was used in the design. Furthermore, the following chapter will include all the design steps and the enhancement techniques.

Chapter V

Introduction to ADS and a Sample Simulation

In this chapter, ADS tool is being presented with a sample simulation. ADS Agilent's Advanced Design System 2011, a tool that uses MOM "Method of Moments" to simulate electromagnetic circuits like microwave circuits, microwave electronics, and antennas. The simulation results can be used before implementing or building the circuits in order to check the design, and expected outcome parameters of any design. Hereunder, ADS tool is being presented showing different parameters of the antenna that can be obtained and simulated using ADS. Moreover, a sample simulation is being presented. In this sample simulation, the work in [28], is being built, simulated, and compared with the antenna design.

5.1 Sample antenna design using ADS:

A sample microstrip patch antenna has been designed in ADS as an example. This sample antenna is the work in [28]. To start with, ADS simulator is opened and a new workshop file is chosen. Then the technology or the resolution of our simulation is chosen. After that a new schematic is open to draw the antenna layout and dimensions as in Fig.53.

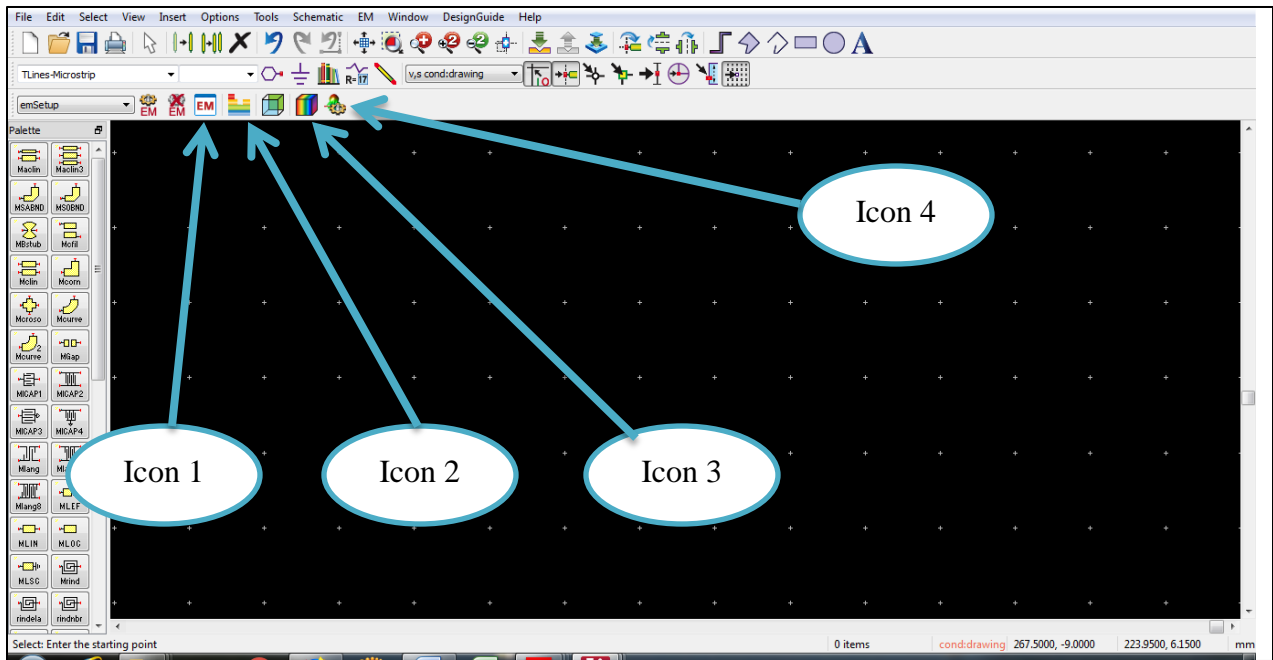

Fig.53 Schematic workspace of ADS

There is couple of important icons that needs to be presented from Fig.53, which are:

- Icon 1:
This icon opens the Electromagnetic Simulator where the simulation frequency can be set.
- Icon 2:
This icon defines the different layers of the antenna and the type and characteristics of each material
- Icon 3:
This icon is used for the 3-D simulation and the animation of the antenna over the operated frequency rang.
- Icon 4:
This icon is used to define the parameters for the 3-D Simulation.

To start with, by using icon 2 and as in Fig.54, the antenna cross section is defined. Different layers of conductors, substrates (dielectrics), VIAs. Moreover, the electromagnetics characteristics as well the thickness of each layer is define.

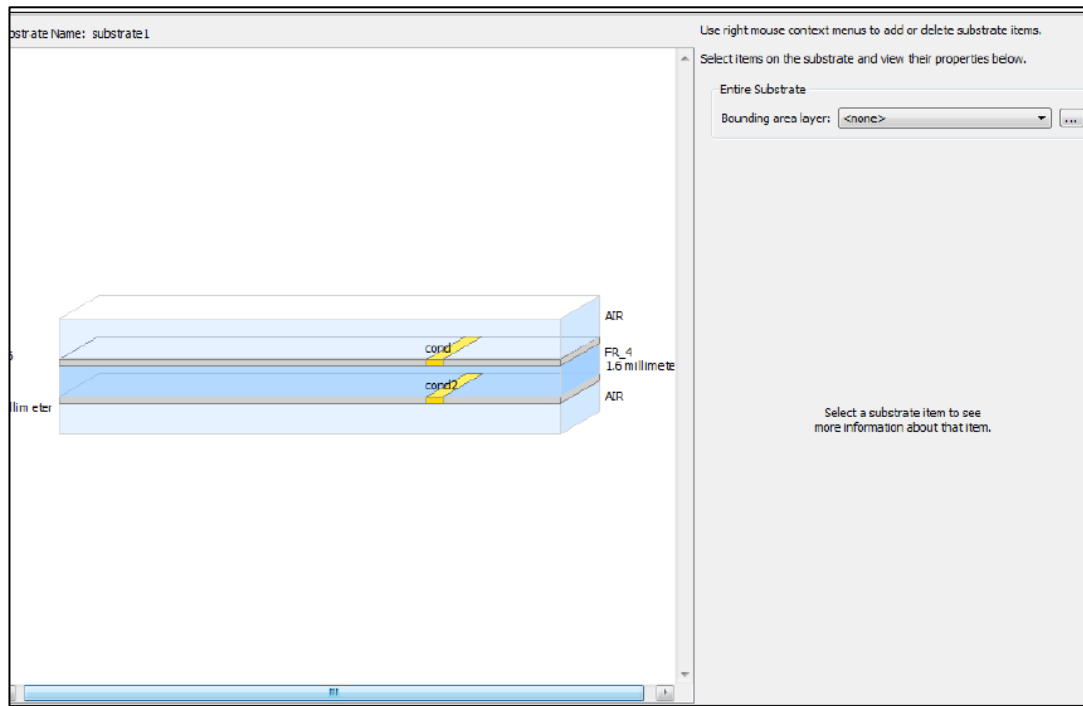

Fig.54 Defining the Sectional layers of the antenna

Then, the antenna is built in the layout plane by using the different defined materials as in Fig.56 whereas Fig.55 represents the antenna in [28]. Different materials with different dimensions are placed in the layout plane. It is important to use the same materials that are defined in the earlier stage.

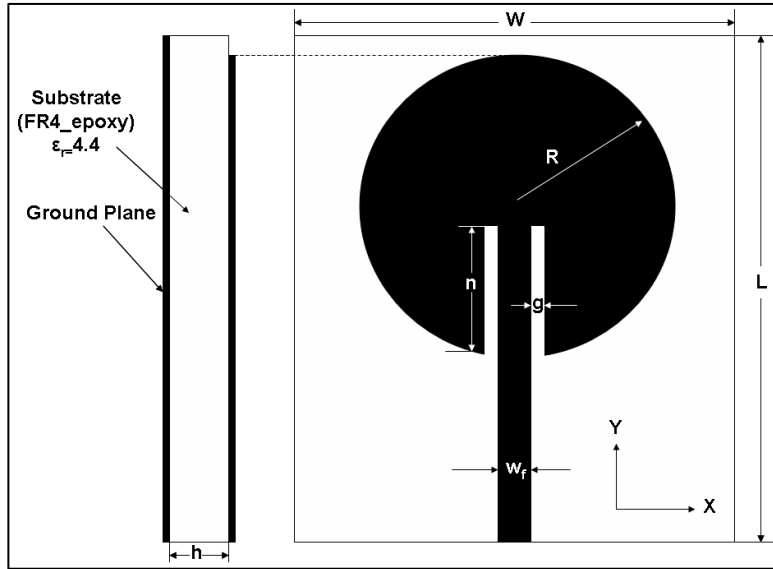

Fig.55 Antenna of work [28]

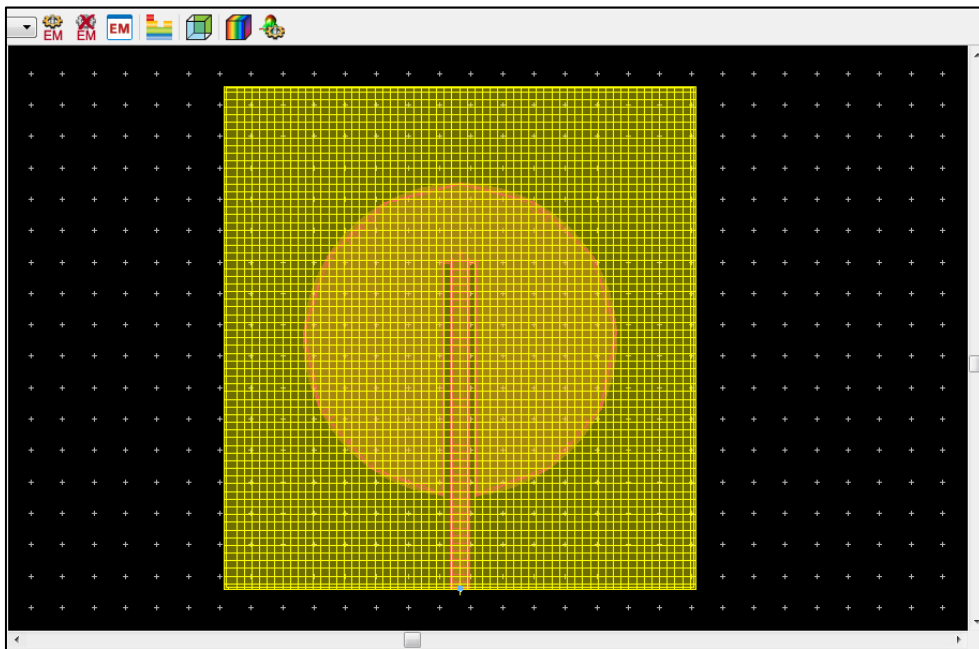

Fig.56 Sample Antenna (example) is placed in the layout plane

By using icon 1, different simulation parameters is defined like the frequency applied, number of iterations and other parameters that has to be defined before simulating the constructed antenna. Once the simulate button is clicked, ADS simulator will take some time to perform all the calculations and simulations before the results page appears as in Fig.58 comparing to simulation of the actual work of [28] as in Fig.57.

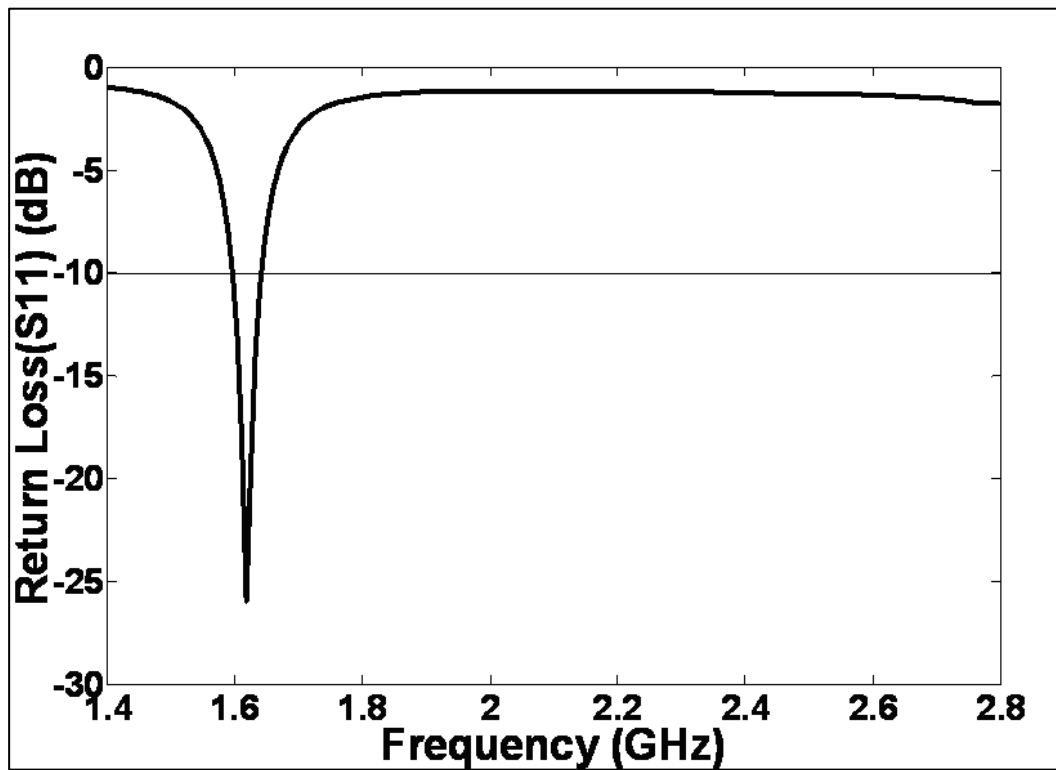

Fig.57 Results of the antenna in [28]

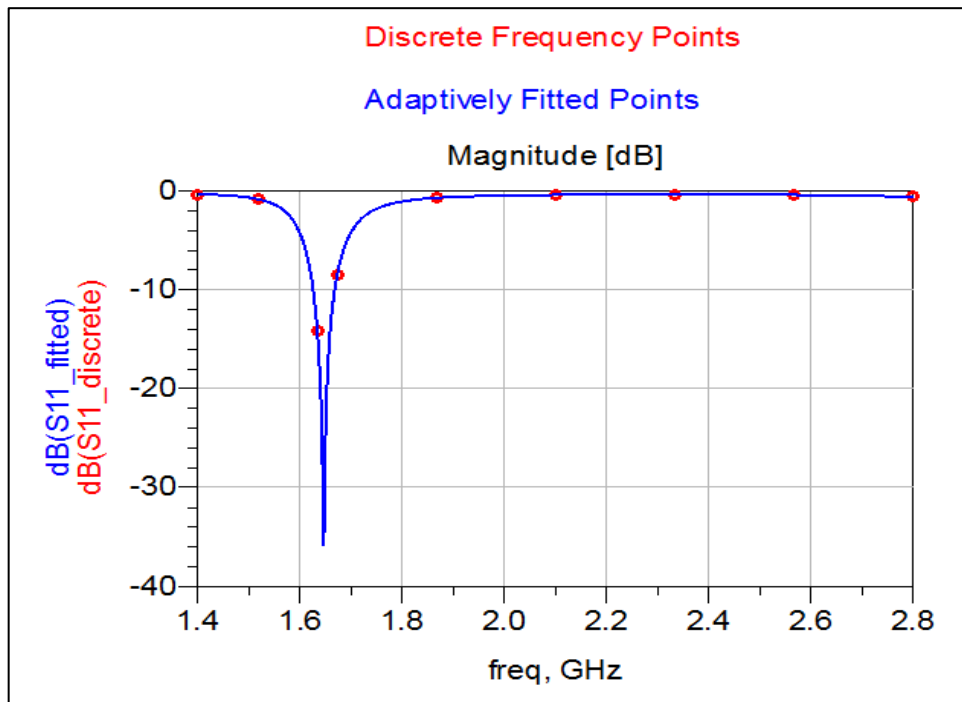

Fig.58 Results of the simulated example antenna

For the 3-D simulation and to check the other parameters of the antenna icon-4 is used to specify at which frequency to operate the simulator. After that, icon-3 is used to obtain the different parameters of the antenna like the surface current as in Fig.59, radiation pattern of the antenna as in Fig.60, and antenna parameters as in Fig.61.

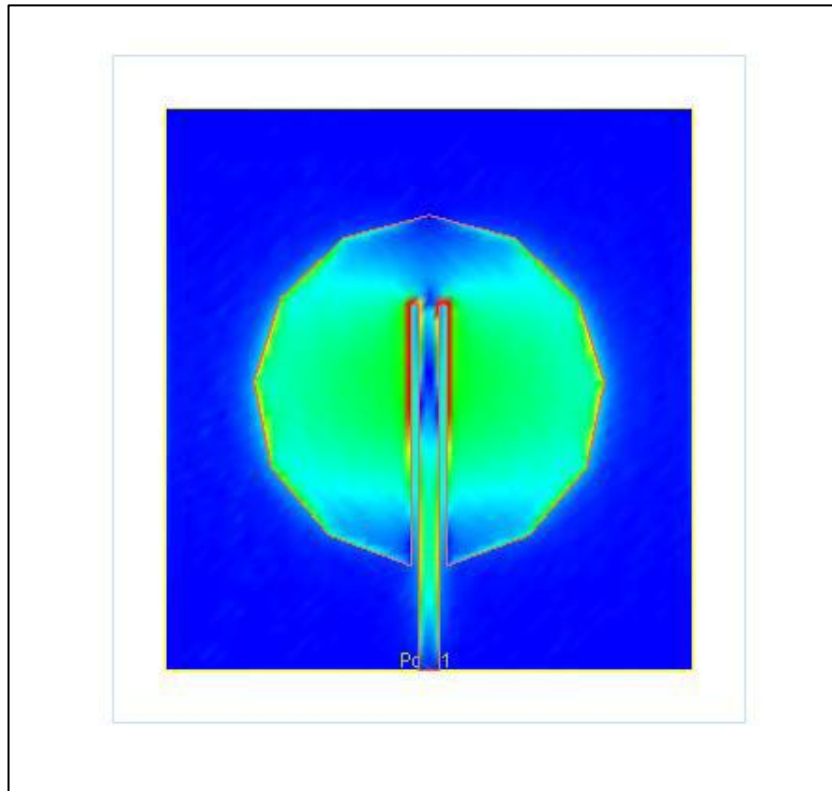

Fig.59 Surface current of the example antenna

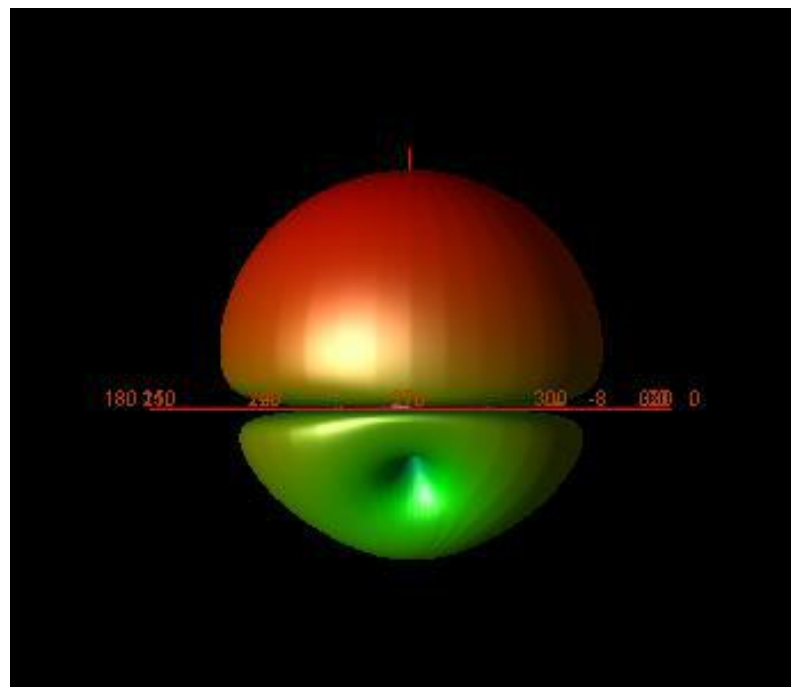

Fig.60 Radiation pattern of the example antenna

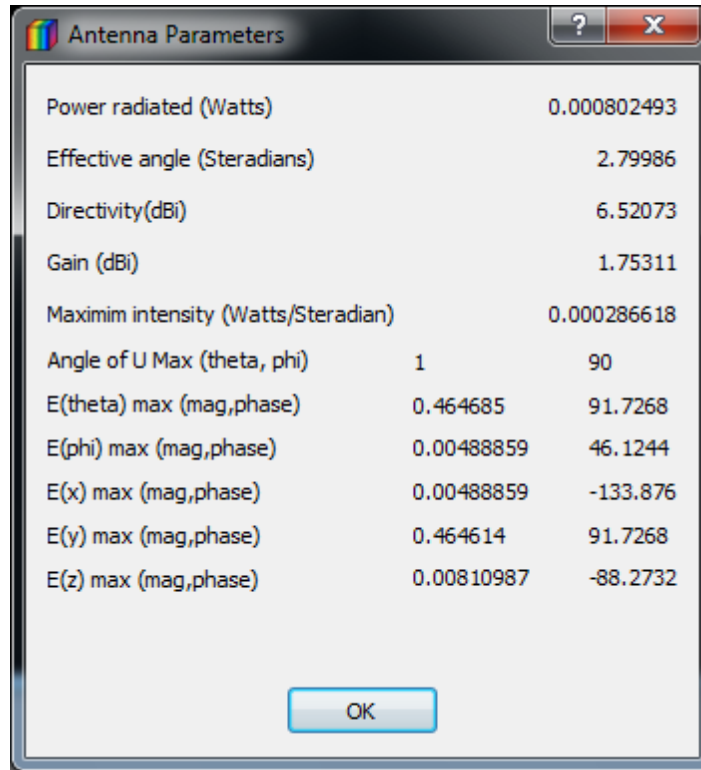

Fig.61 Different parameters of the example antenna

Moreover, Gain, Directivity, the axial ratio, the polarization and the absolute fields can be obtained from 3D simulation as in Fig.62, Fig.63, and Fig.64.

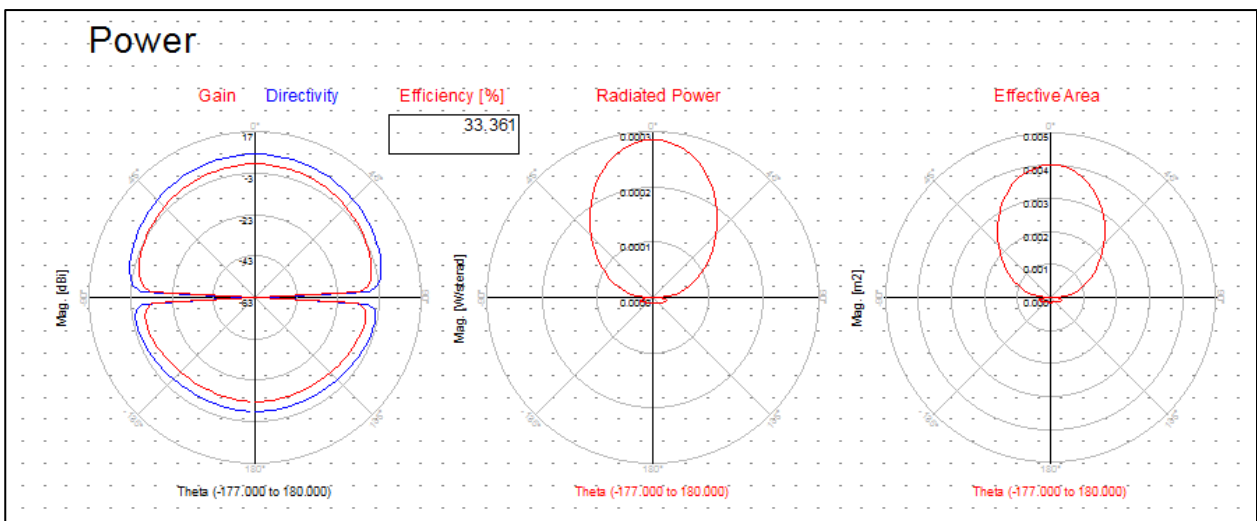

Fig.62 Gain and Directivity of the example antenna

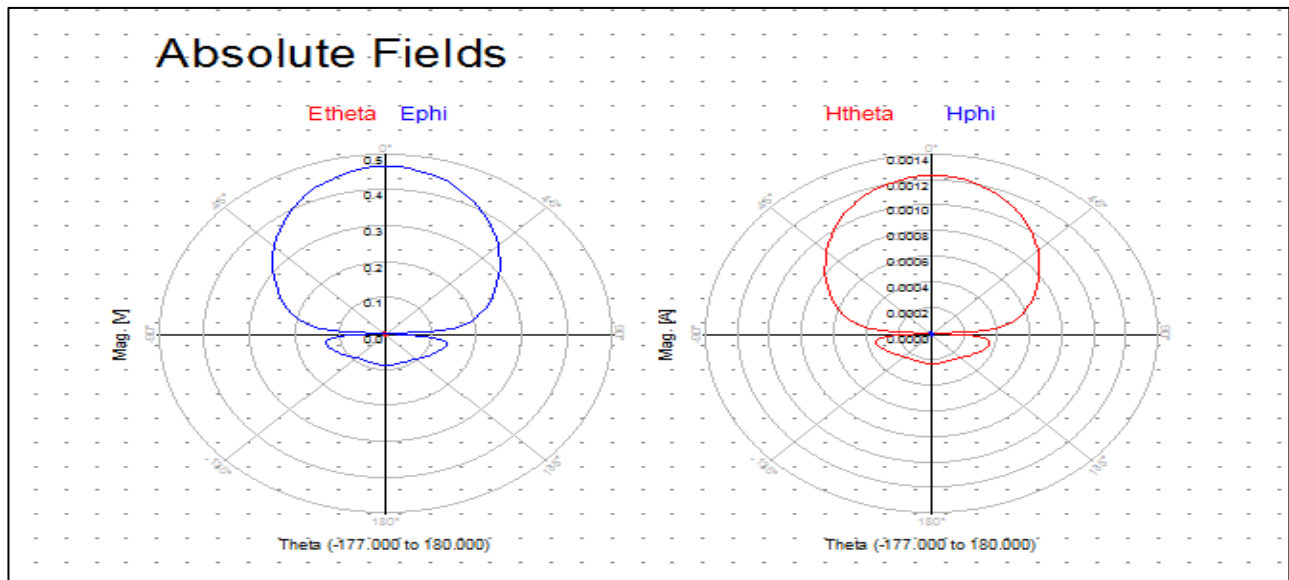

Fig.63 Absolute Fields of the sample antenna

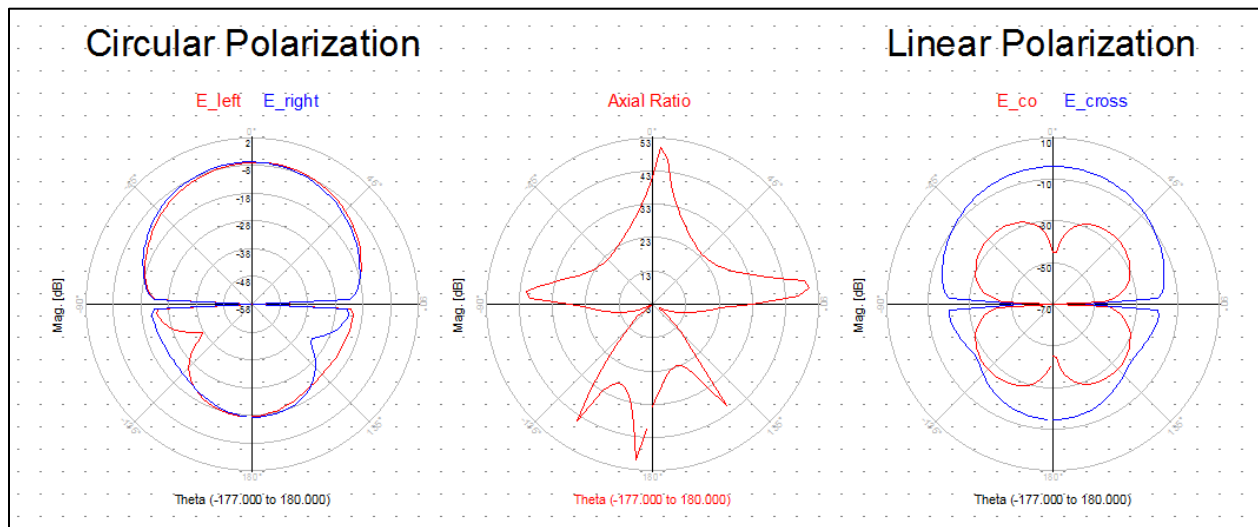

Fig.64 Axial Ratio and the Polarization of the example antenna

It is important to note that for the different simulations and designs, the 3-D simulator is operated only at one frequency at a time. Therefore, to obtain the axial ratio of the antenna over a certain frequency span, the simulator has to be simulated at each frequency and the results to be tabulated. After that, it can be plotted using other programs like Microsoft Excel.

Chapter VI

Design of a Multiband Stacked Microstrip Patch antenna for Satellite Communications

In this chapter, a Multiband stacked microstrip patch antenna was designed. The antenna has multiple resonant frequencies that can be utilized to serve satellite communications as well as other communication systems. The main resonant frequency designed at 1.487 GHz, where 25 MHz bandwidth of Circular polarization is achieved. The antenna consists of three conducting surfaces, one serve as a ground plane and the other two as radiating antennas. Moreover, the two conducting surfaces are coupled through two conducting VIAs. In addition, the antenna uses two different feeding techniques which are Microstrip line and VIAs. The designed antenna is easy to model, fabricate, manufacture, and implement on other communication systems and electronics.

The design of our antenna has gone through different phases. The first phase is construct antenna that has a circular polarization. After that, we developed the antenna to have wider bandwidth. Then, different techniques have been explored to develop the antenna performance and to have more resonant frequencies. The last phase, is finalizing the different parameters of the proposed antenna.

6.1 Design of Simple Microstrip Patch antenna that radiates at 1.6 GHz

The main aim of this thesis is to develop a microstrip patch antenna that can be utilized in satellite communication. Since mobile and handheld devices antennas' design has developed over the years, antennas that are used for satellite communications especially with the handheld devices needs to improve. The main improvement to these antennas over the time is converting from monopole antennas to microstrip patch antenna since microstrip patch antennas are smaller, compact and easy to integrate with the handheld devices. However, the same has not been considered for satellite communications. As a result, the main contribution of the thesis is to develop a microstrip patch antenna that can be used instead of monopole antennas in the handheld devices for satellite communications. A case study was considered is Thuraya Satellite Communication Company which has a widely spread handheld devices but with monopole antennas. Thuraya is using both 1.5 GHz and 1.6 GHz as center frequencies for Satellite communication Uplink and Downlink respectively. It is worth mentioning that Thuraya considerations is for the study purposes to prove the concept only whereas the same can be extended over the other Applications / Satellite Companies.

A simple microstrip patch antenna is proposed to radiate around our desired resonant frequency 1.6 GHz. The Simple Antenna consists of two conducting materials that are separated by an FR_4 Dielectric Material. The feeding method in the simple designed antenna is the simplest and direct method of feeding which is Microstrip line. The designed antenna has a resonant frequency at 1.6 GHz and a Circular polarization Bandwidth from 1.53 GHz to 1.56 GHz achieving around 30 MHz of Circular polarization Bandwidth.

6.1.1 Simple Antenna Design:

Simple rectangular microstrip patch antenna was considered in the beginning. To design a rectangular microstrip patch antenna, there are five steps that need to be followed as defined by Balanis in [2]. The five steps are:

Step 1: Calculation of the Width (W):

$$W = \frac{c}{2f_0 \sqrt{\frac{(\epsilon_r + 1)}{2}}} \quad (3)$$

Step 2: Calculation of the Effective Dielectric Constant ϵ_{eff} :

$$\epsilon_{eff} = \frac{\epsilon_r + 1}{2} + \frac{\epsilon_r - 1}{2} \left[1 + 12 \frac{h}{W} \right]^{-\frac{1}{2}} \quad (4)$$

Step 3: Calculation of the Effective length:

$$L_{eff} = \frac{c}{2f_0 \sqrt{\epsilon_{eff}}} \quad (5)$$

Step 4: Calculation of the length extension ΔL :

$$\Delta L = 0.412h \frac{(\epsilon_{eff} + 0.3) \left(\frac{W}{h} + 0.264 \right)}{(\epsilon_{eff} - 0.258) \left(\frac{W}{h} + 0.8 \right)} \quad (6)$$

Step 5: Calculation of actual length of the patch:

$$L = L_{eff} - 2\Delta L \quad (7)$$

- Where the following parameters are used:
 1. f_0 : Resonance Frequency
 2. W : Width of the Patch
 3. L : Length of the Patch
 4. h : Thickness of the Patch antenna
 5. ϵ_r : Relative Permittivity of the dielectric substrate
 6. c : Speed of light: 3×10^8 m/s²

Therefore, to design a rectangular microstrip patch antenna, three main parameters need to be defined which are the dielectric material (the substrate), thickness of the substrate, and the operating frequency of the antenna. The dielectric material that is proposed to be used is FR_4, which is a widely used dielectric material with a relative permittivity ϵ_r of 4.6. The main reason for choosing this material is the availability and the wide utilization of this material in microstrip patch antennas.

Both Balanis [2] and the work in [16] suggest corner cuts on a square patch antenna to achieve circular polarization. As a result, design in [16] was considered as a reference for the circular polarization considerations in our antenna design. Therefore, the thickness of the simple antenna was considered 3.2mm similar to the work in [16]. However, the design of [16] is using two stacked substrates, air and FR_4, of 1.6mm thickness each.

The last parameter to design our antenna is the operating frequency which is chosen to be 1.6 GHz as indicated earlier. By designing our antenna following the five steps of Balanis [2], the Width of the antenna is 55mm and the length of the antenna is 43 mm.

The antenna was designed and constructed using ADS as in Fig.65 and return loss as in Fig.66.



Fig.65 Simple rectangular antenna

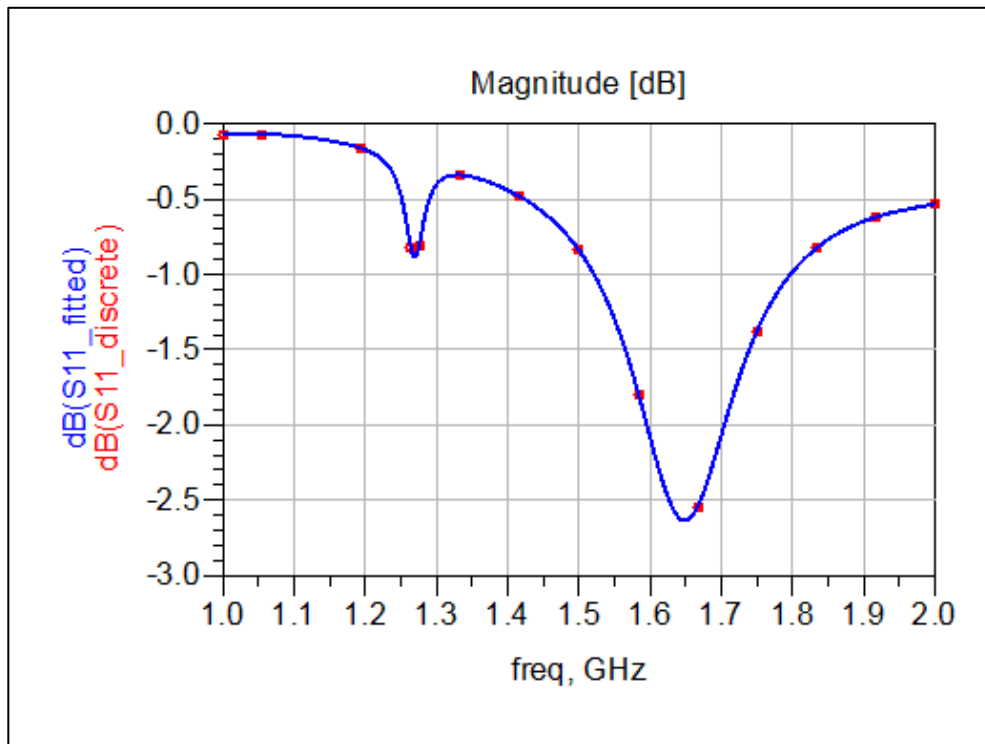

Fig.66 Return loss of the simple rectangular antenna

However, this antenna is not square antenna. Therefore, to apply Balanis [2] and the work in [16] in order to obtain circular polarization, the antenna dimensions needs to be modified to be square antenna. It is important to note that, for microstrip patch antennas, theoretical equations applies for the simplest antenna designs like rectangular patch antenna. However, for more complicated designs, the implementations or simulations results define mainly how each design stage affected the antenna behavior. As a result, the antenna dimensions were modified to maintain the same results obtained in the simple antenna; hence the dimensions of the antenna became a square antenna of 45 x 45 mm dimensions.

45 mm x 45 mm antenna was constructed in ADS and simulated to check for the resonant frequency. Fig.67 represents the antenna layout. Fig.68 represents the return loss of the constructed antenna.

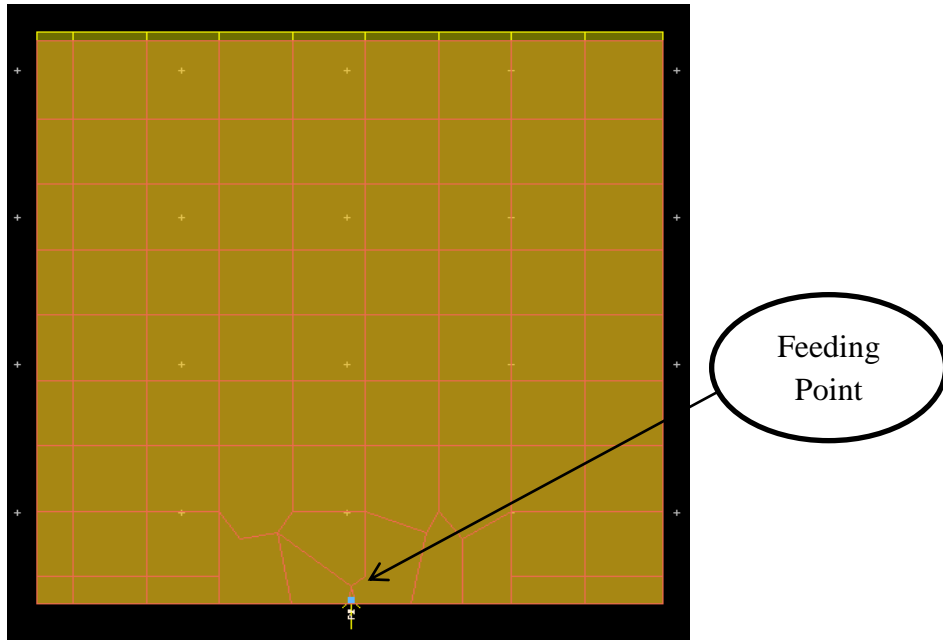

Fig.67 Simplest square antenna

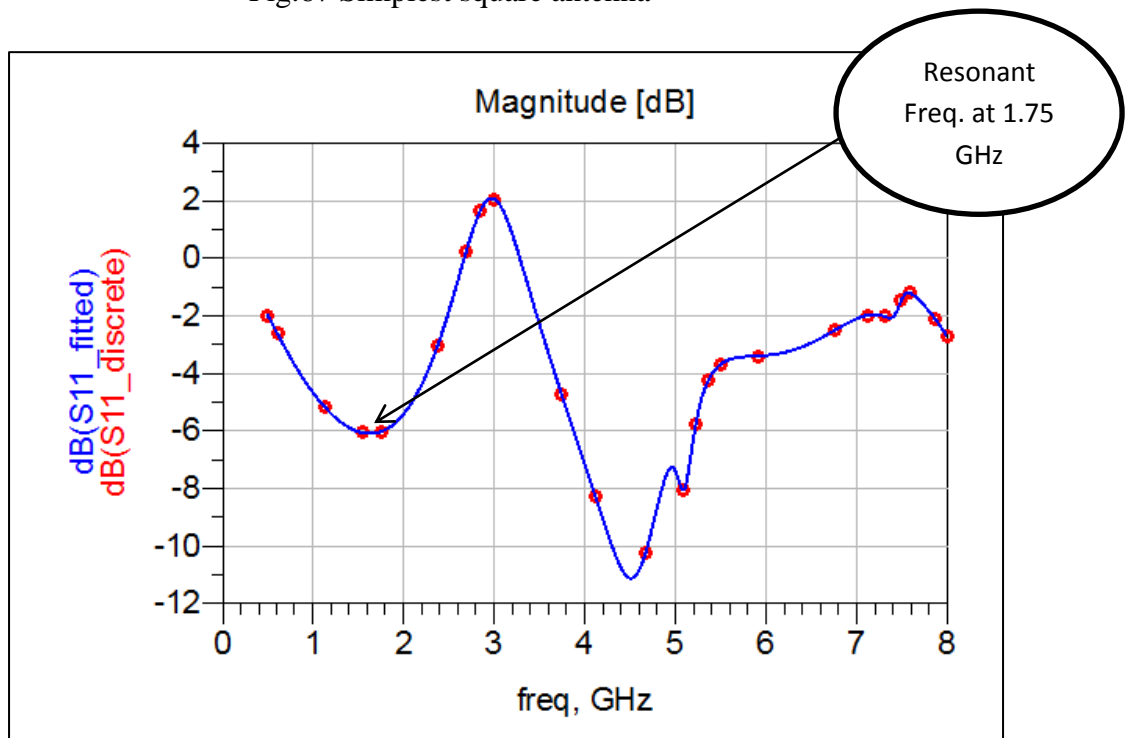

Fig.68 Return Loss of the simplest square antenna

This simple square antenna return loss falls around the resonant frequency of our desire which is 1.6 GHz. However, the resonance frequency needs further modifications in order to have better matching. Furthermore, this rectangular antenna is not expected to have a circular polarization. As a result, two main parameters of this antenna need to be modified. The first is the Circular polarization of the antenna. The second thing is matching at the desired resonance frequency.

6.1.2 Circular Polarization and Resonance Frequency Modifications:

From the work in [16], the corner cut to achieve circular polarization is 13 mm with 45 degrees angle. Giving the length or the width is 47.6 mm, then the length of the cut is $13 \cos 47.6 = 9.19$ mm. As a principle, if the percentage of the cut is applicable, hypothetically, then for a rectangular antenna with center feed a corner cut of $9.19 / 47.6 = 0.193$ or 19.3 % of the sides will result in an antenna that has a circular polarization performance at the center frequency. Applying this principle to our designed antenna of 45 x 45 rectangular antenna to check the possibility to obtain the same results. The corner cut to our antenna is 19.3 % of 45 mm = 8.69 mm. The antenna is constructed as in Fig.69 with the corner cuts calculated earlier. CP of the antenna is better to be obtained after having better matching of the resonant frequency. Therefore, after having the resonant frequency with a good matching, the circular polarization of the antenna is obtained.

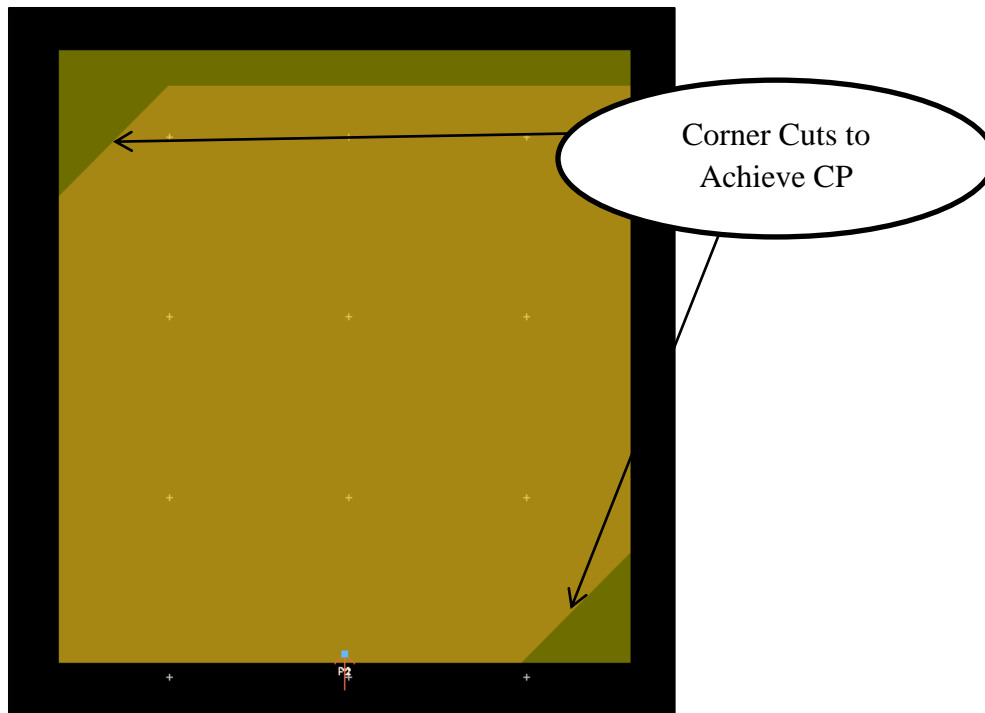

Fig.69 45 x 45 mm Antenna with corner cuts to achieve circular polarization

One of the simplest ways of enhancing the matching at the resonance frequency of the antenna is to increase the matching between the feeding point and the antenna itself. The feeding line that feeds the antenna has certain impedance. On the other hand the antenna as a complete object has also overall impedance. Matching the antenna impedance with the feeding point impedance decreases the amount of the reflected signals to the feeding point due to the mismatching of the impedances. Therefore, one of the useful methods to increase the matching between these two ends is using a feeding line which will match the impedance of the two different ends. ADS gives a simple way to find the details of the feeding line dimensions through the use of the LineCalc tool, as in Fig.70, tool which will calculate the length of the feeding line. This feeding either it is extended to the antenna or it is an inset in the antenna itself.

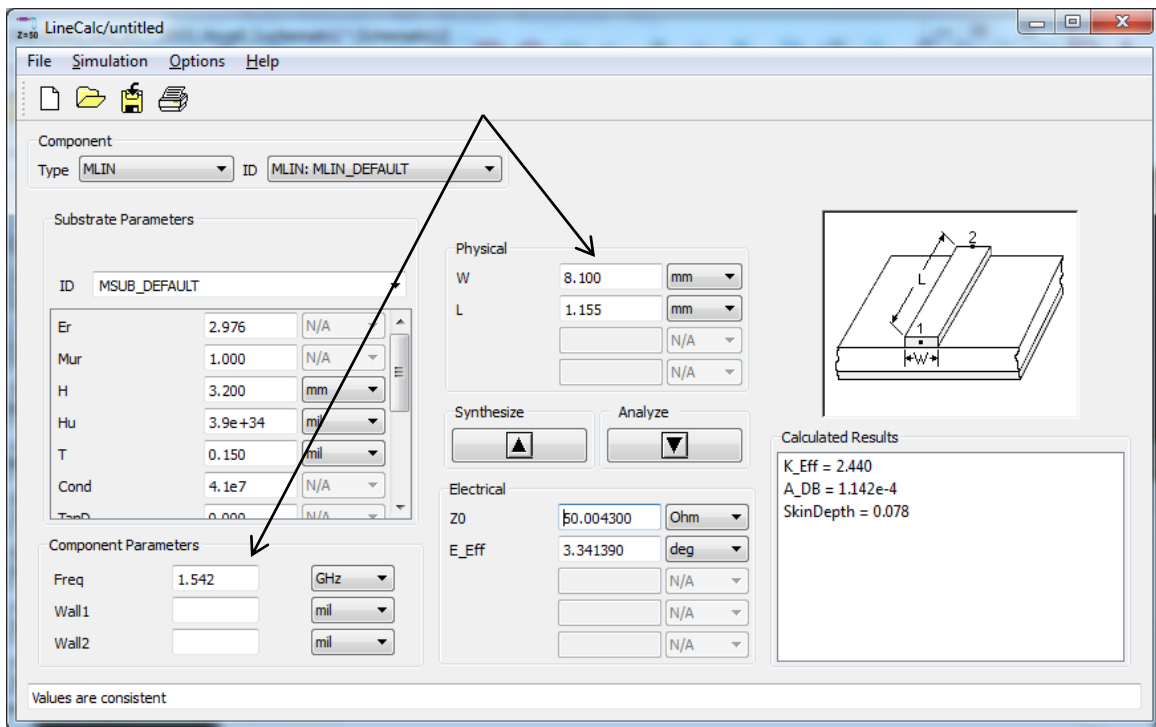

Fig.70 LineCalc tool in ADS to find the length of the Feeding line

In our design we explored both options as in Fig.71 and Fig.72. Fig.73 and Fig.74 respectively represents the return loss of both options and hence, the matching at the resonant frequency. As the simulations shows, the first option of extending the matching feeding line has better matching and better bandwidth especially around our desired frequency of 1.6 GHz. Therefore, the first antenna is considered in our design to be the simple designed antenna for a circular polarization and a resonant frequency around 1.6 GHz. Furthermore, this antenna will be enhanced in the following sections to improve its performance in terms of the matching, CP bandwidth, additional matching bands that can be utilized for satellite communications as well as other communication systems.

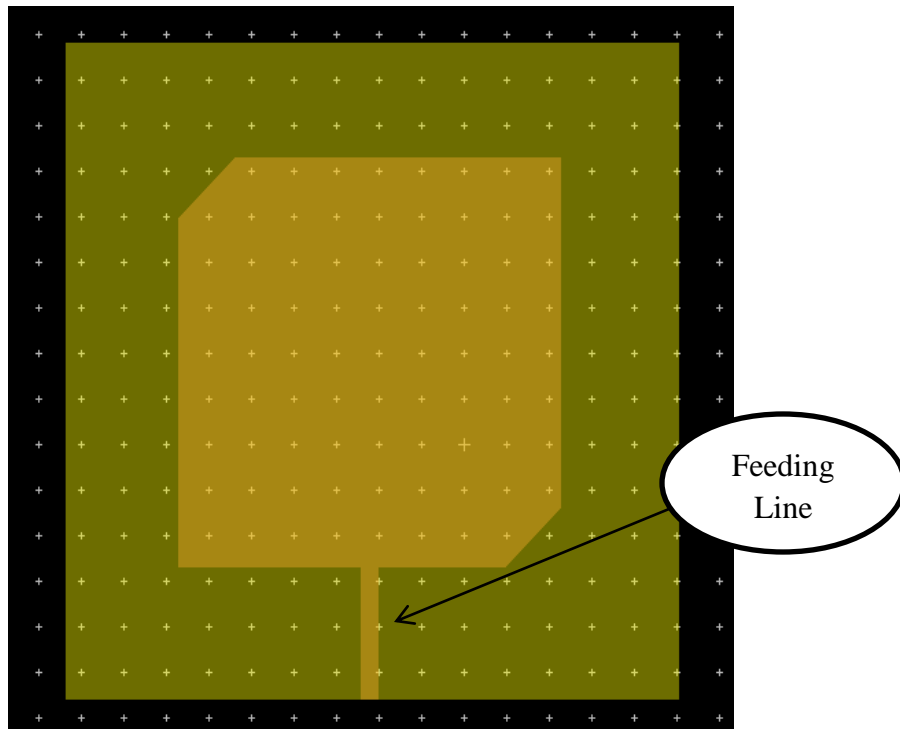

Fig.71 Proposed with extended feeding line

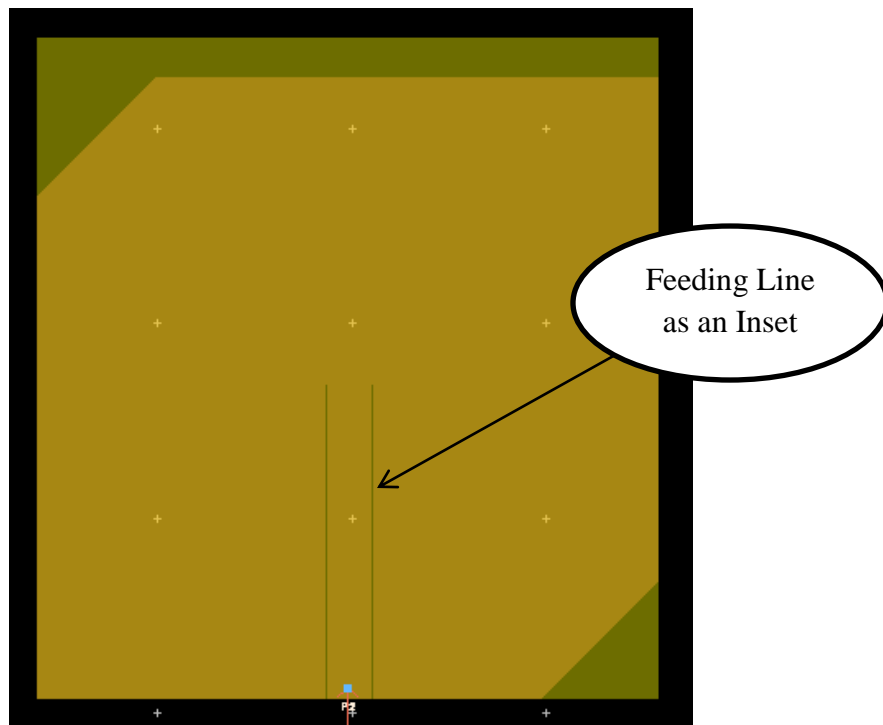

Fig.72 Antenna with inset matching line

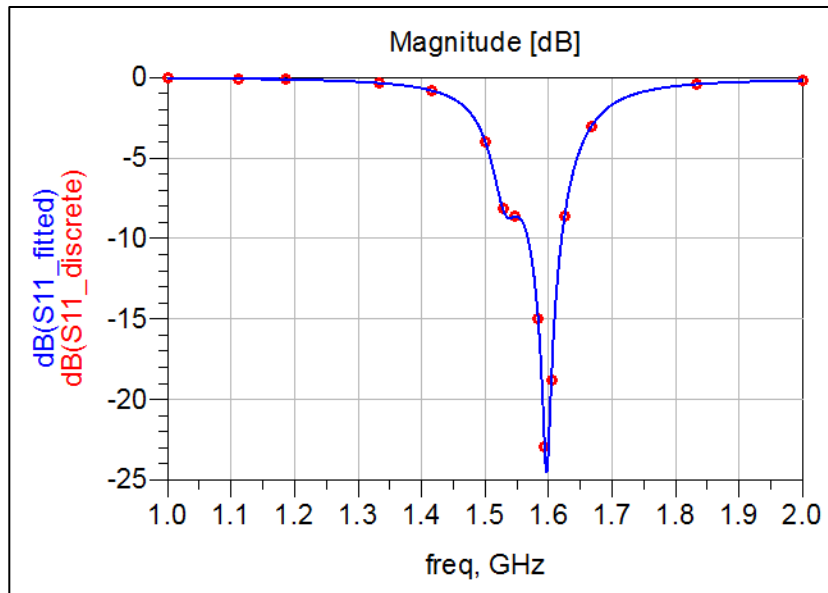

Fig.73 Return loss of antenna in Fig.71

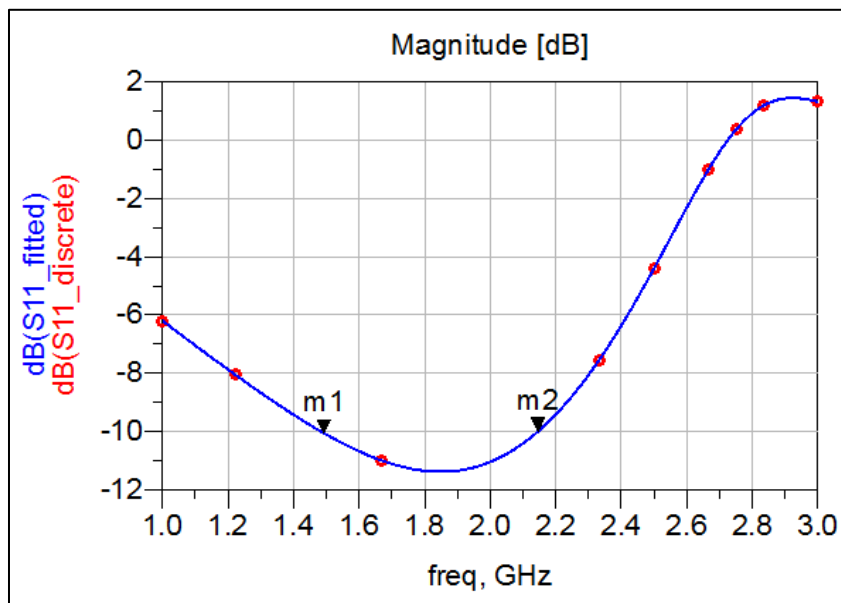

Fig.74 Return loss of antenna in Fig.72

After choosing the simple antenna design, the circular polarization of the antenna is explored. As presented earlier the method of obtaining the polarization of an antenna, the same was followed in our antenna. Circular polarization of an antenna is directly related to the Axial Ratio of the antenna at different frequencies. The antenna is considered to have a circular

polarization if the axial ratio of the radiating element of the antenna is 0 dB. However, for the practical applications 3 dB Axial ratio or below is an acceptable value to consider the antenna is having a circular polarization at a certain frequency. Fig.75 represents the axial ratio of the antenna designed.

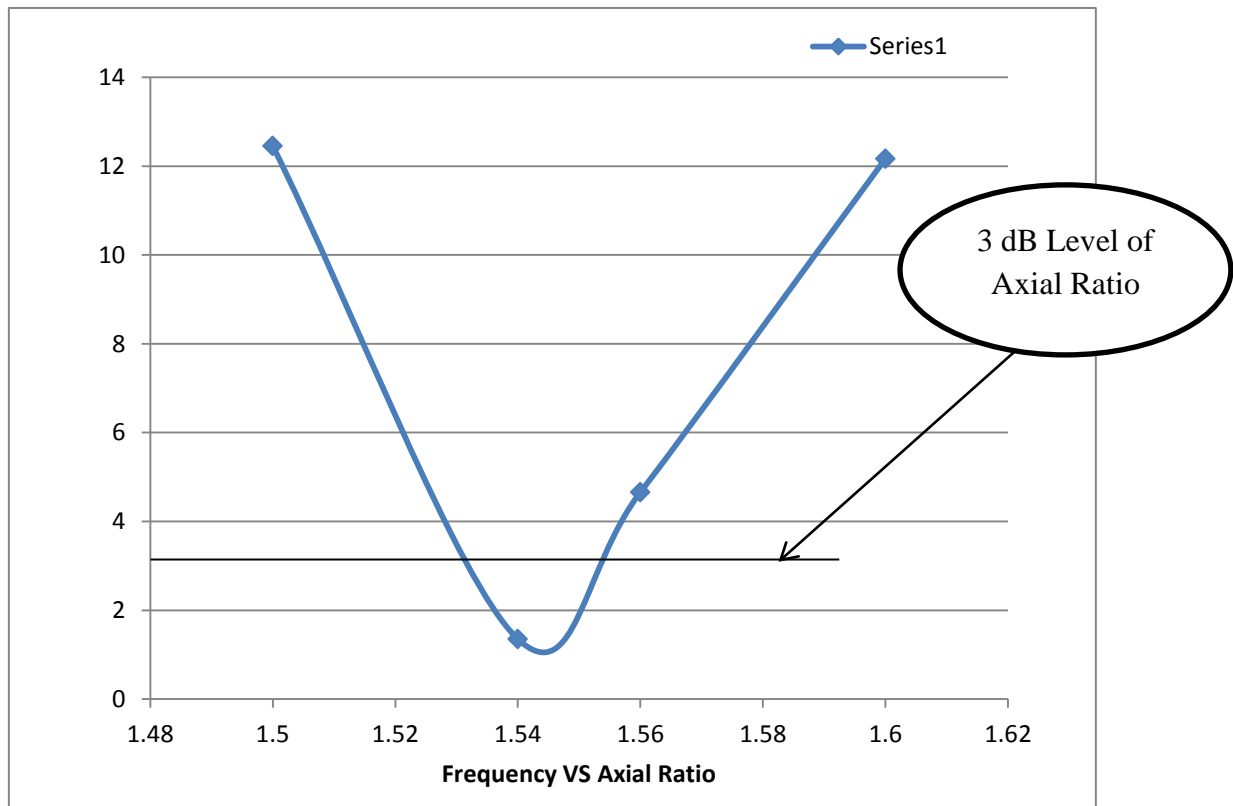

Fig.75 Axial Ratio of the simple antenna

From the proceedings, the axial ratio of 3 dB and less is from around 1.53 GHz to 1.555 GHz. Therefore, circular polarization is achieved over this bandwidth of 25 MHz. Moreover, the simple antenna is simulated from 0.5 GHz to 6 GHz as in Fig.76 to check for other resonant frequencies. The results obtained show a good matching of the antenna at 3 GHz and around 5.8 GHz.

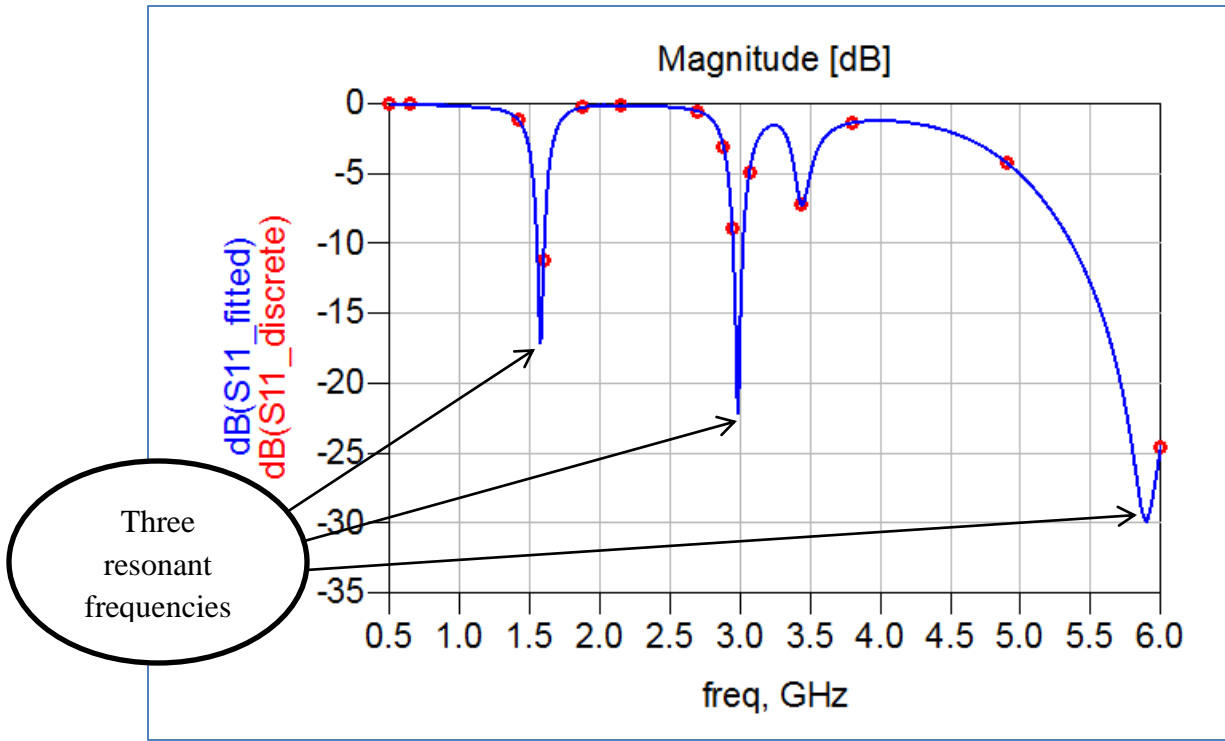

Fig.76 Return loss of the simple antenna from 0.5 GHz to 6 GHz

6.2 Improving the antenna bandwidth at the resonant frequency:

After finalizing the simple antenna that is chosen for our design, different enhancement techniques were explored and applied to our antenna in order to improve the bandwidth of the simple antenna. The simple antenna designed have a resonant frequency around 1.6 GHz. However, the bandwidth of this resonant frequency is very narrow. Moreover, the circular polarization bandwidth obtained is somehow falling to the left of the resonant frequency. Therefore, in this section the antenna is modified to have a wider bandwidth at the desired resonant frequency. However, the resonant frequency shifts to the left due to this modification to be around 1.48 GHz with a wider bandwidth of around 50 MHz. The modified antenna has three layers of conducting materials, the ground plane and two more conducting patches on top of each other. The middle patch is the same of the simple antenna fed through feeding line. The other patch on top of the simple antenna is being fed through a VIA from the lower patch.

Modified Antenna Design:

Now, different enhancement techniques is explored in order to improve the bandwidth of the simple antenna at the resonant frequency 1.6 GHz . The following presentation represents the major techniques implemented to obtain the desired bandwidth:

6.2.1 Extra layer on top with Electromagnetic coupling:

Having obtained matching of the antenna with the given structure of the antenna as in Fig.71, then by adding another layer on top of the antenna having the same formation but with slightly a shrink dimensions, it is expected to have matching at the same resonant frequency or slightly at a lower frequency, hence having two close by resonant frequencies or having one

resonant frequency with wider bandwidth. Fig.77 represents the antenna cross section of the added patch and the substrate material which is similar to the material used for the lower antenna substrate. Furthermore, Fig.78 shows the schematic of the antenna with the top layer that matches the lower antenna “the simple antenna”, but with shrunk dimensions.

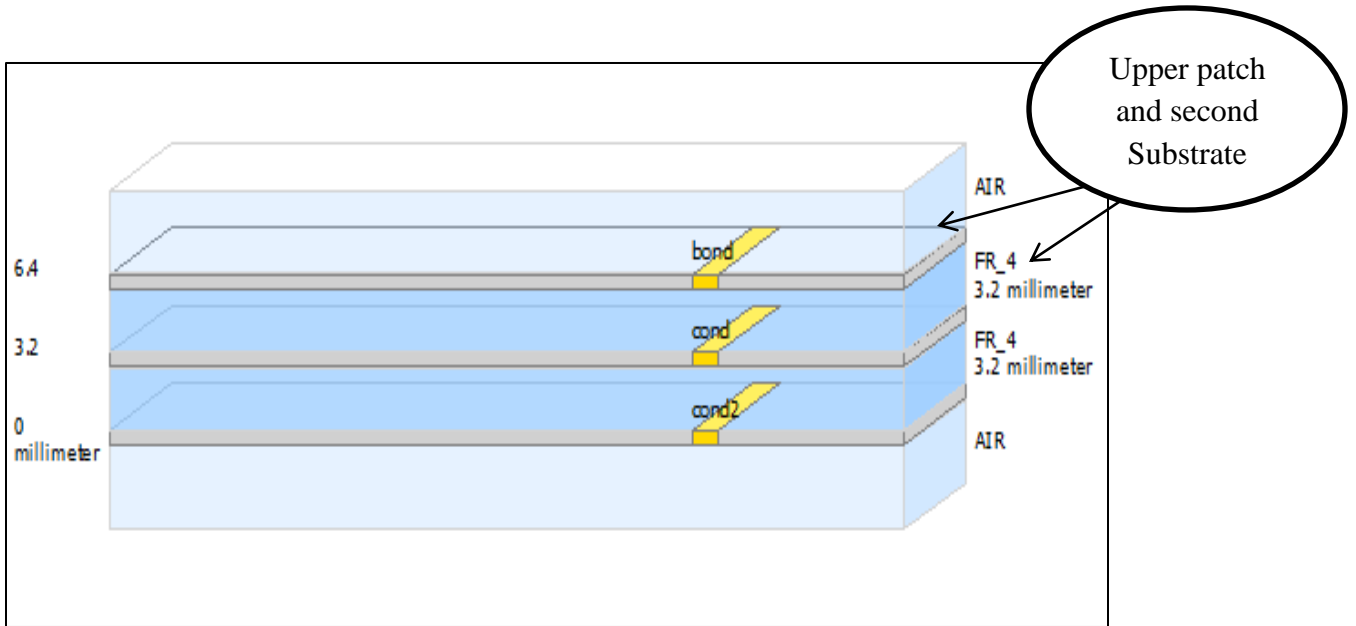

Fig.77 Two patch antenna cross section

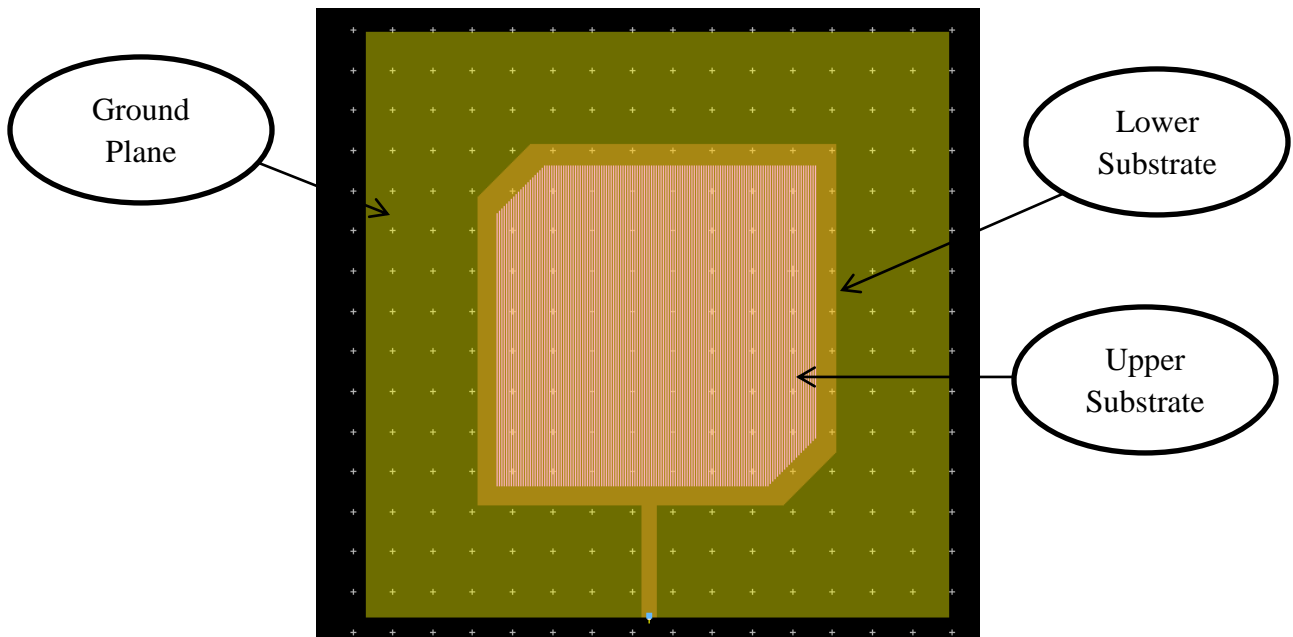

Fig.78 Schematic of the two patch antenna

The antenna is simulated and the result of the return loss of the antenna is shown in Fig.79. From the return loss, it is obvious that the bandwidth of the antenna shifted to the left towards lower frequencies around 1.48 GHz. The main reason for that shift of the resonant frequency is the upper new patch.

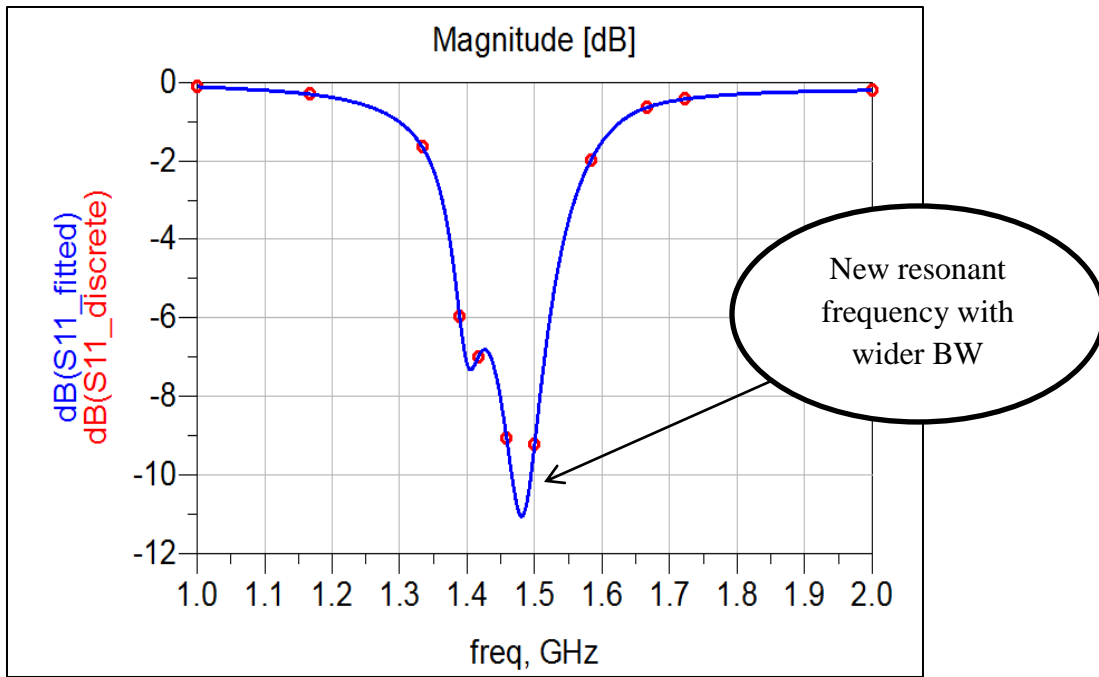

Fig.79 Return loss of the two patch antenna

In addition, the antenna simulated at 1.5 GHz and the surface current of the antenna was obtained as in Fig.80. The main reason of the surface current simulation is to check the coupling between the two patches. Currently, the upper patch is being fed through the electromagnetic coupling between the two patches, which induces a surface current on the upper patch and hence the upper patch radiates the signals. Having a good coupling between the two patch antennas means that the majority of the radiated signals from the lower patch is being transferred to the upper patch and hence radiated from the whole antenna. On the other hand, if there is a poor

surface current on the upper patch that means there is high percentage of the signals radiated from the lower patch is being reflected back. Therefore and as It is clearly obvious in Fig.80, there is a very low surface current on the top antenna while there is a good current surface on the lower antenna. Having low surface current on the top antenna, means there is a low electromagnetic coupling between the upper and the lower antennas. In our goal to enhance the antenna performance, a conducting VIA was added between the two layers to improve the electromagnetic coupling between the two layers.

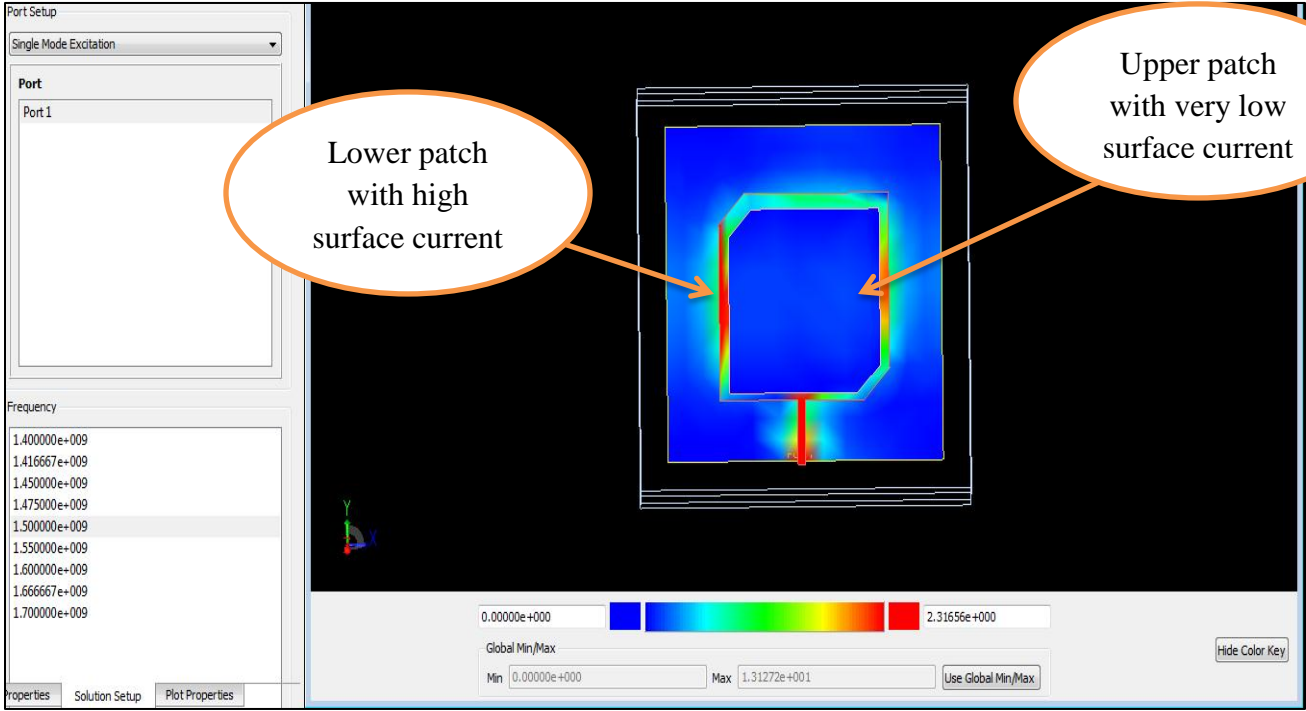

Fig.80 Surface Current of the electromagnetically coupled two patches

6.2.2 Extra layer on top with VIA conductor:

Giving that the upper antenna has a relatively very low electromagnetic coupling with the lower antenna, therefore, a conducting VIA is proposed to be between the two conducting layers in order to have better surface current on the top antenna and hence having better matching at the resonant frequency. Fig.81 shows the antenna cross section with the VIA, while Fig.82 show the antenna schematic with the VIA being located at the center of the lower and upper patch.

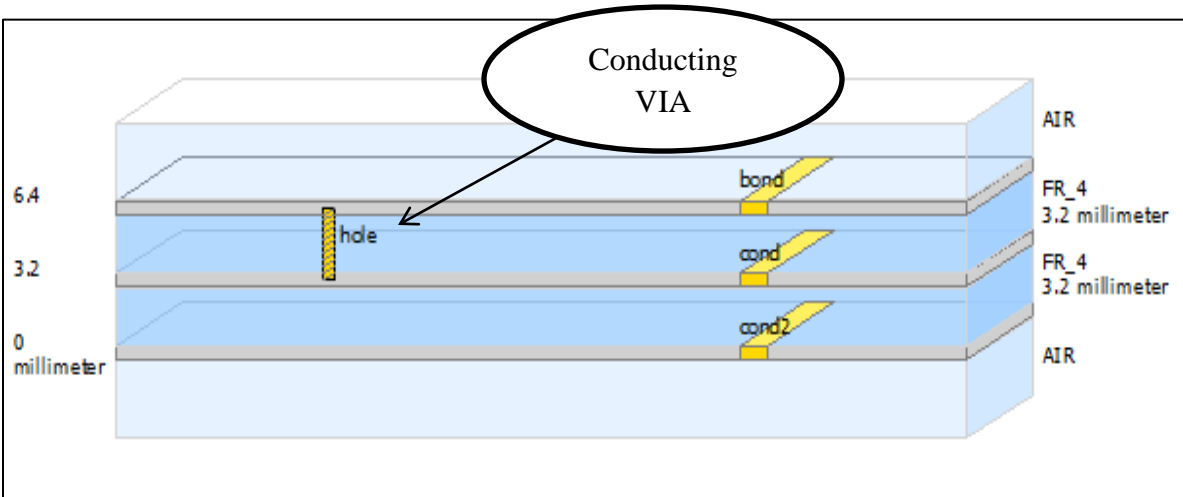

Fig.81 Antenna cross sections with VIA being added between the two patched

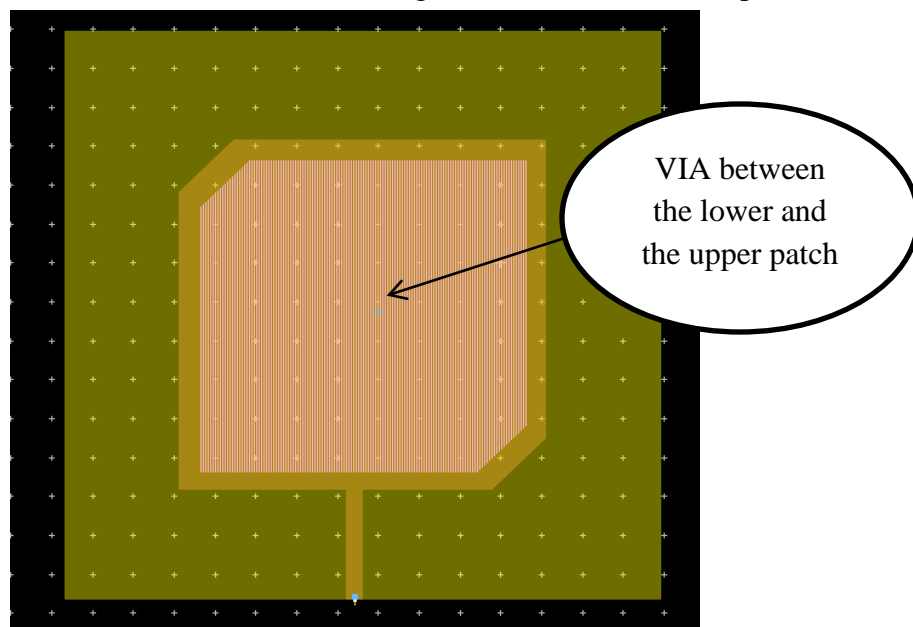

Fig.82 Schematic of the VIA

The antenna is simulated and return loss of the antenna with a VIA coupling the two patches in shown in Fig.83. It is obvious from the simulations that there is not huge difference between the two methods. However, there is a better matching when the VIA was used. Therefore, the VIA is kept and further enhancement was done to the antenna in order to improve its bandwidth.

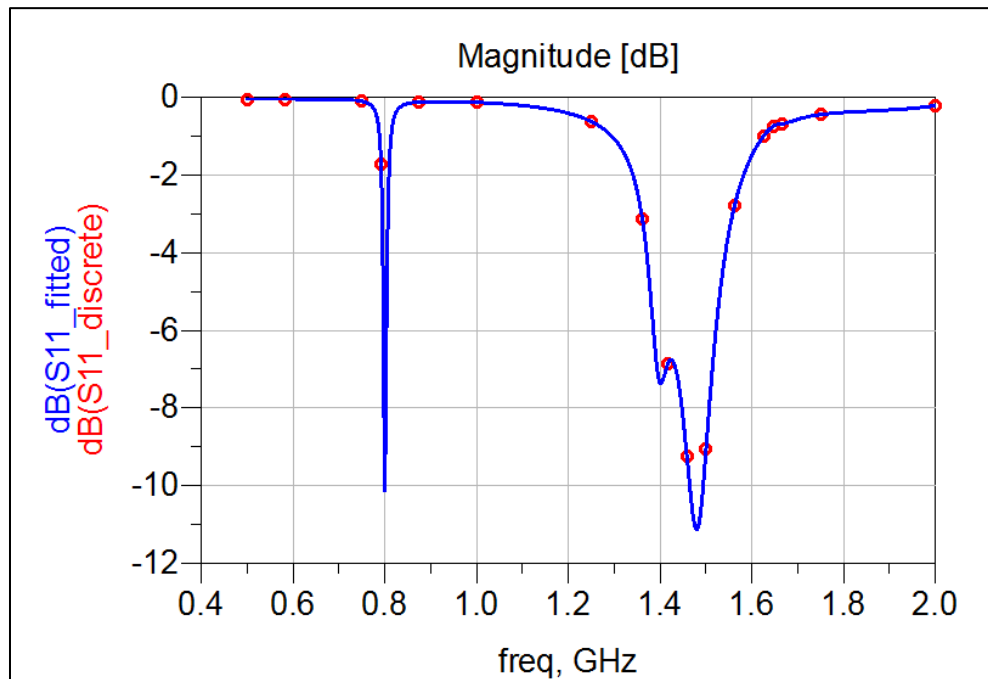

Fig.83 Return loss of the Antenna with VIA between the two patches

6.2.3 Changing the location of the VIA and the Conductor size:

Giving that the major radiated signals from the center of the antenna, the conducting VIA that is coupling the two conducting layer is moved along the center line of the antenna. Moreover, the VIA cross section is increased in order to increase the coupling between the two layers. Two locations are studied for the VIA along the center line of the antenna. Once it was on the left of the center of the antenna as in Fig.84. The other location was to the right of the center of the Antenna as in Fig.85.

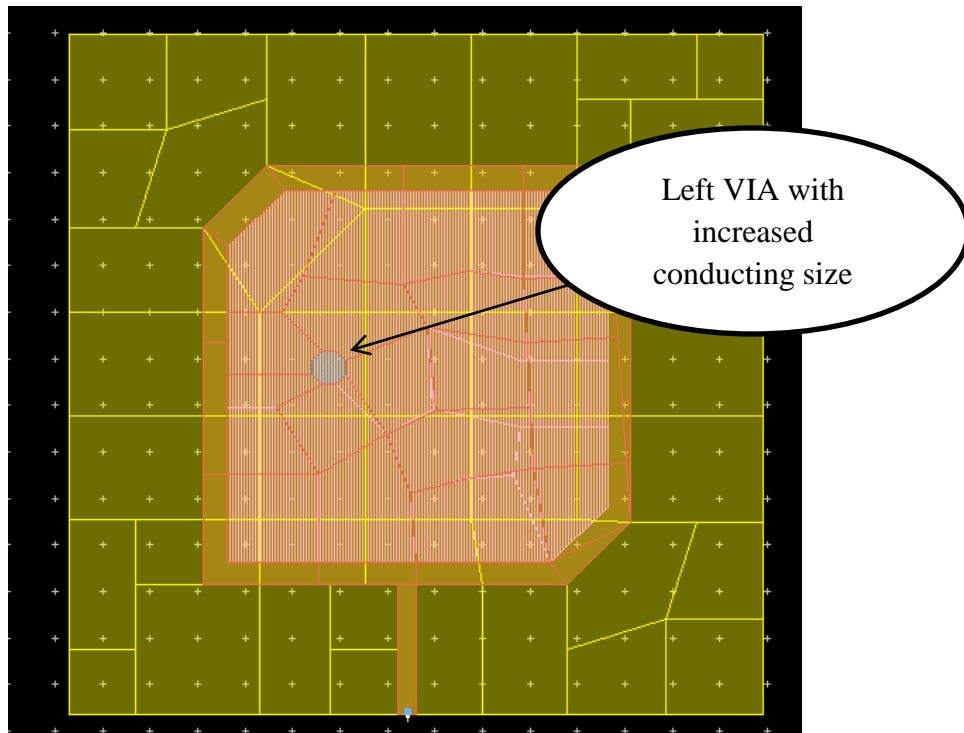

Fig.84 Antenna with Left VIA, and increased VIA conductor size

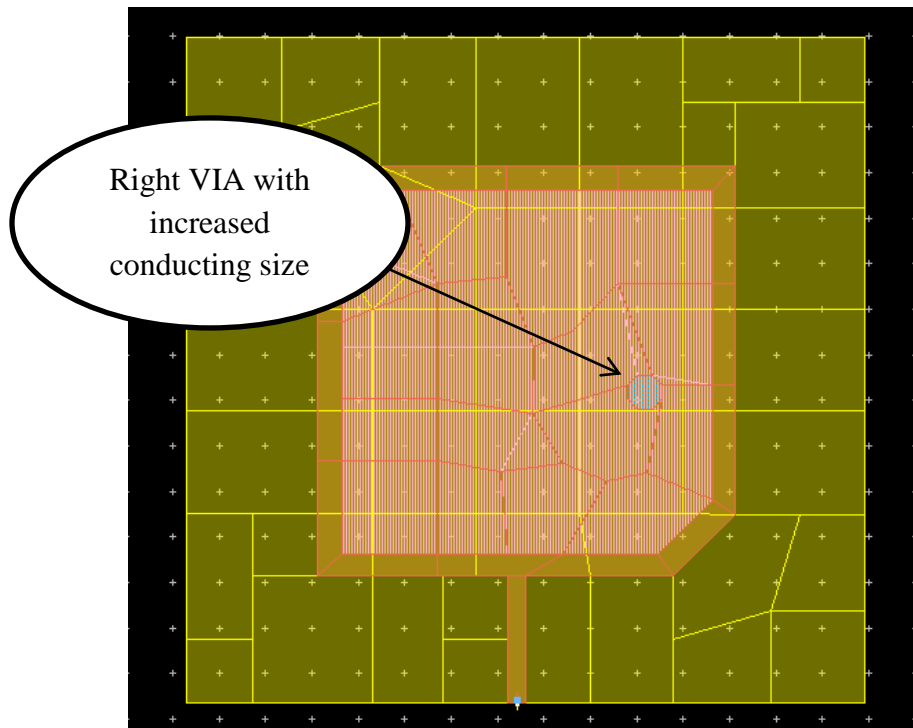

Fig.85 Antenna with Right VIA, and increased VIA conductor size

Both antennas were simulated for the return loss as in Fig.86, 87 for both left and right VIA respectively. From the simulations it is obvious that the antenna with the conducting VIA to the right is having better matching at the resonant frequency. Moreover, it has a slightly better bandwidth.

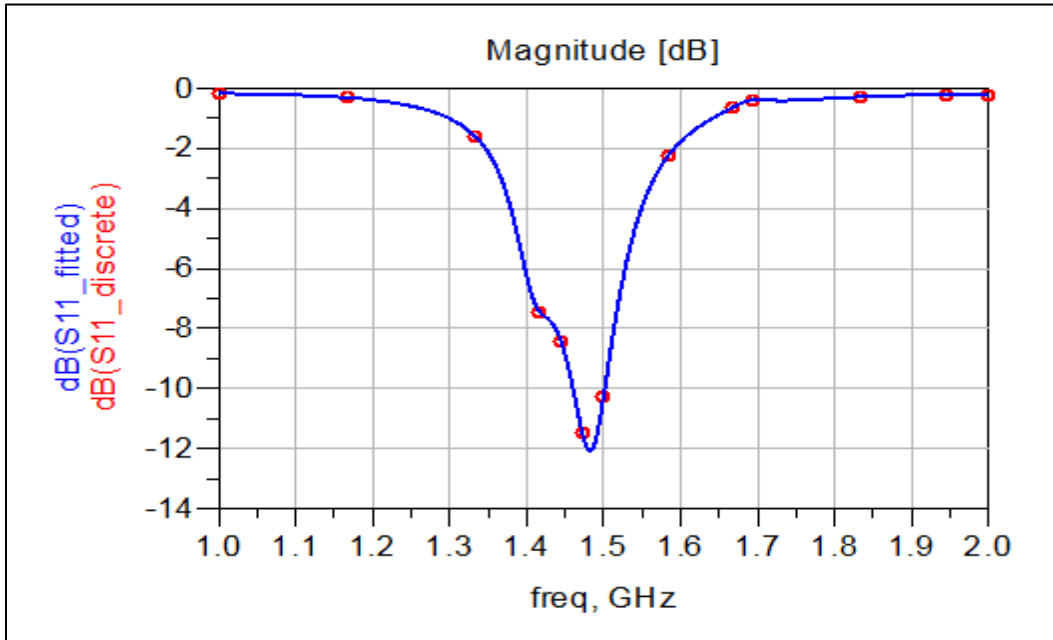

Fig.86 Left VIA return loss

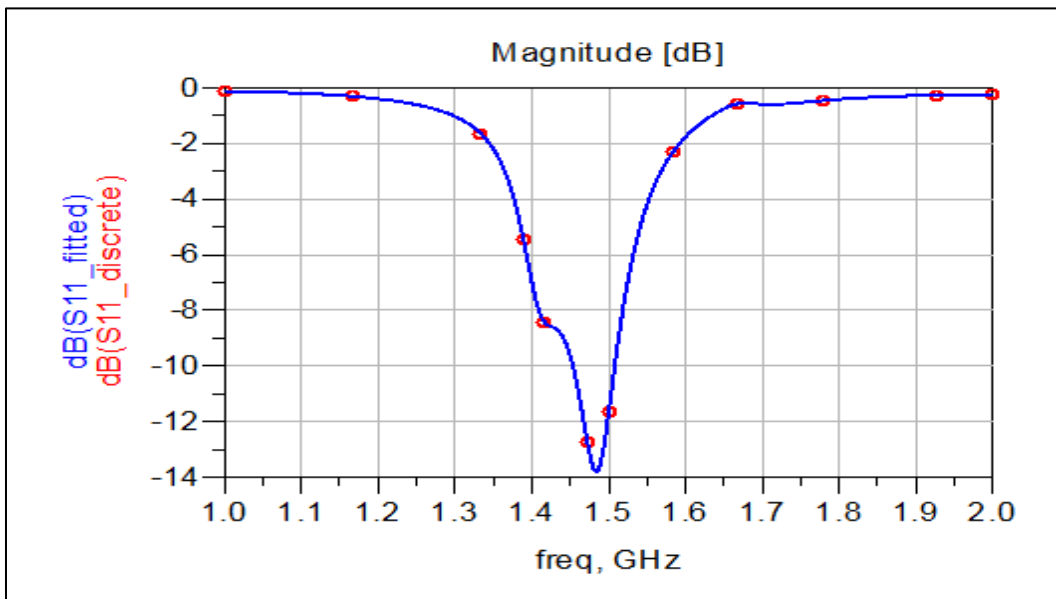

Fig.87 Right VIA return loss

Moreover, the surface current obtained of the two antennas at 1.55 GHz as in Fig.88 for the left VIA antenna and Fig.89 for the right VIA antenna. From the simulation results obtained in ADS, there is not much different between the two simulations in terms of the surface current. As a result and since the right VIA has a better mating, it was chosen as the modified antenna in this section. In the following section the modified antenna, as in Fig.85, will be enhanced further in order to obtain more matching and resonant frequencies that will be used for other communication systems.

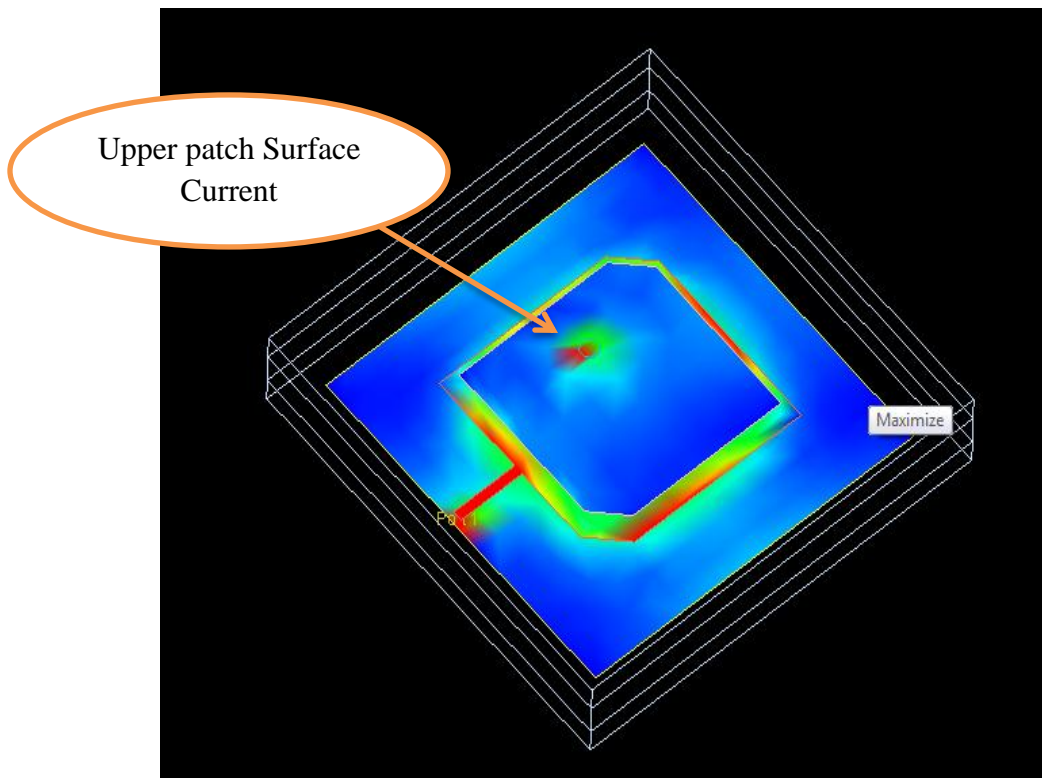

Fig.88 Left VIA surface current

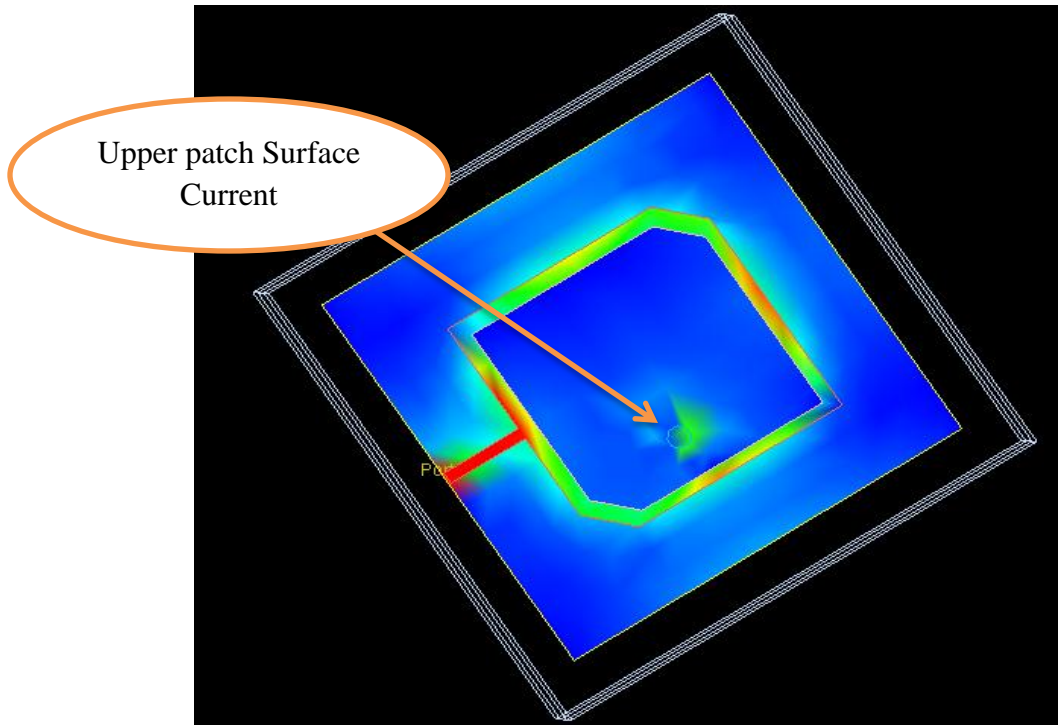

Fig.89 Right VIA surface current

6.3 Modification to the antenna to obtain more resonant frequencies:

From the proceedings, the considered antenna up to this stage is the antenna as in Fig.85, which consists of a ground plane, two conducting surfaces connected through a conductor VIA. For the chosen antenna, further enhancement techniques were explored in order to get more resonant frequencies. The main reason for is that allowing the antenna to operate at multiple bands in addition to the satellite communications bands. As a result, another conducting VIA was added in between the lower and the patch.

As presented earlier in the literature review, many enhancement techniques are there to explore. As a result, in the proposed antenna, multiple antenna modification techniques were explored and presented hereafter.

In the following write up different techniques are presented. As we can see from the different methods followed that we tried not to alter the lower antenna, ground plane, and thickness of the lower substrate. The main reason for that is that, these three elements were the bases of our design that have been developed over the last two chapters. Moreover, it is done in order to disturb our obtained circular polarization. Therefore, as a consistence method of developing the proposed antenna, we are building on our previous results, because changing one of these main parameters means the redesigning of the antenna and the process has to be repeated once again.

6.3.1 Making upper patch bigger than the lower antenna:

The upper patch of our antenna is almost is the same as the lower patch. Changing the size of the upper antenna was explored. In this part, enlarging the upper antenna was explored to see how the antenna will perform if the upper antenna is bigger than the lower antenna. It is expected that the antenna will have different resonant frequencies giving that the upper patch has wider space allowing more surface current and hence affecting the radiated signals. As a result, the resonant frequency and the bandwidth of that frequency band will change. Fig.90 represents the antenna with the upper patch bigger than the lower antenna. Moreover, Fig.91 represents the return loss of the antenna. As we can see from the return loss, having a bigger upper patch had a wider bandwidth comparing to our antenna in Fig.87 but slightly shifted to the right. However, the main disadvantage is that the matching itself at the resonant frequency is completely lost and 10 dB return loss is not even achieved over this frequency band.

Proposed upper patch

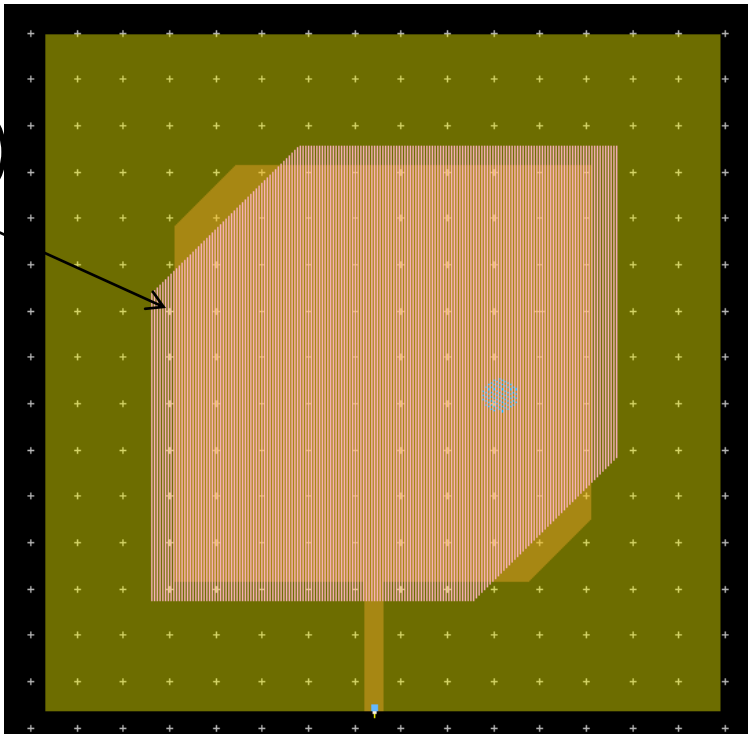

Fig.90 Upper Patch bigger than the lower patch

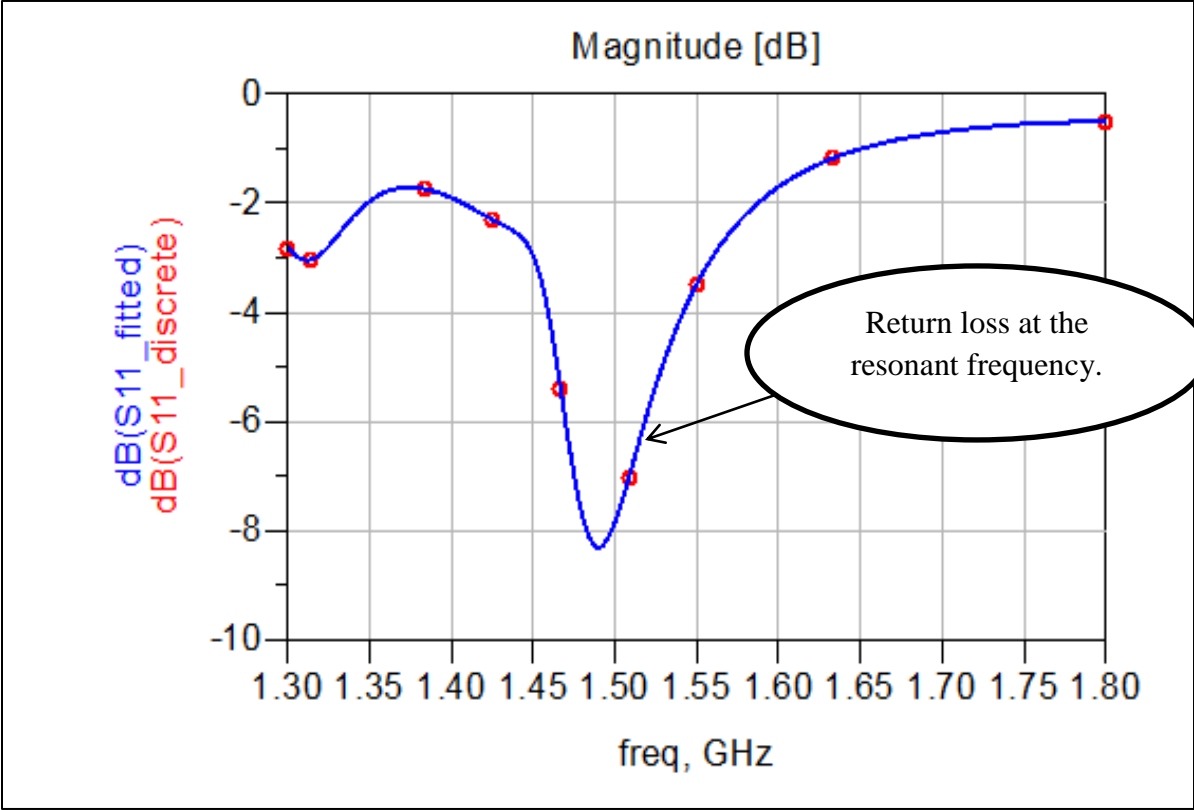

Fig.91 Return Loss of the antenna in Fig.90 at 1.5 GHz frequency

6.3.2 Making upper patch smaller than the lower antenna:

Likewise the previous technique where the upper patch was enlarged in order to check the performance of the antenna at the resonant frequency, the upper patch now is much smaller than the lower patch. Similarly, the upper patch now is expected to have less dimensions for the surface current and hence the bandwidth of the antenna at the resonance frequency will be affected greatly.

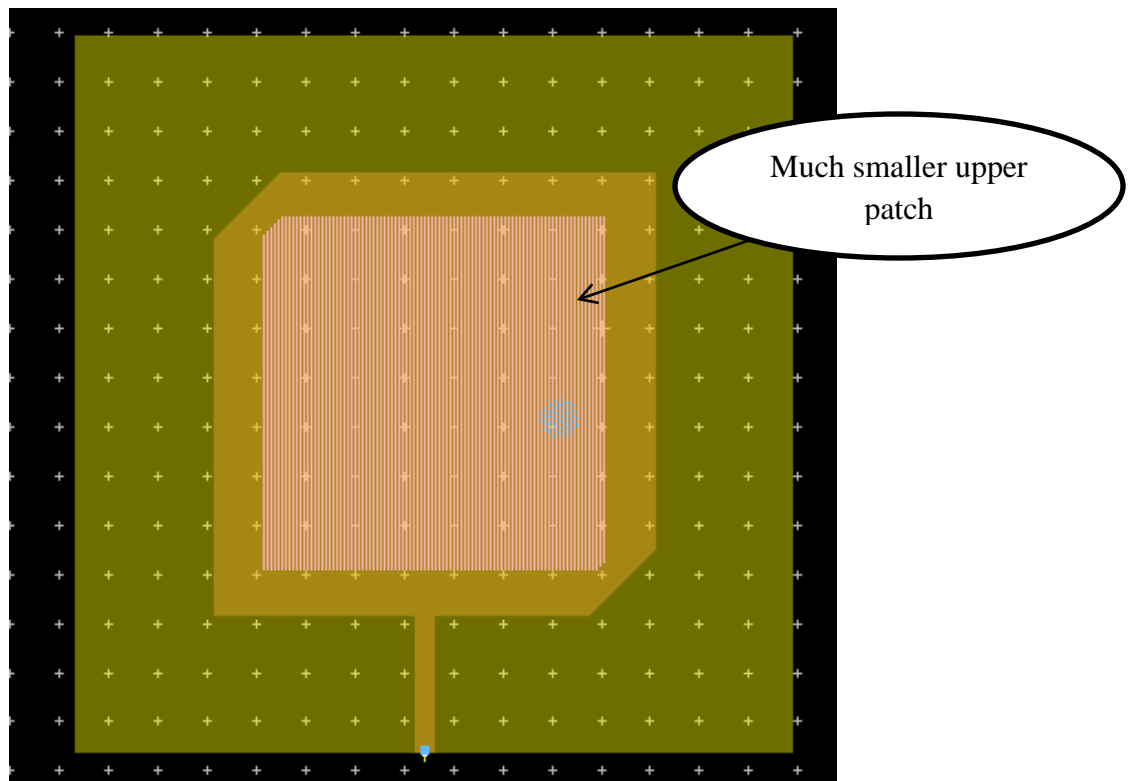

Fig.92 Upper patch much smaller than lower patch

Fig.92 represents the antenna with smaller upper antenna, and Fig.93 shows the return loss of the antenna around 1.5 GHz. As it was expected, even the effect is not much, but the antenna now has better matching, wider bandwidth, and center frequency is shifted slightly to the right. This technique of having smaller upper patch seems promising for further fine tuning.

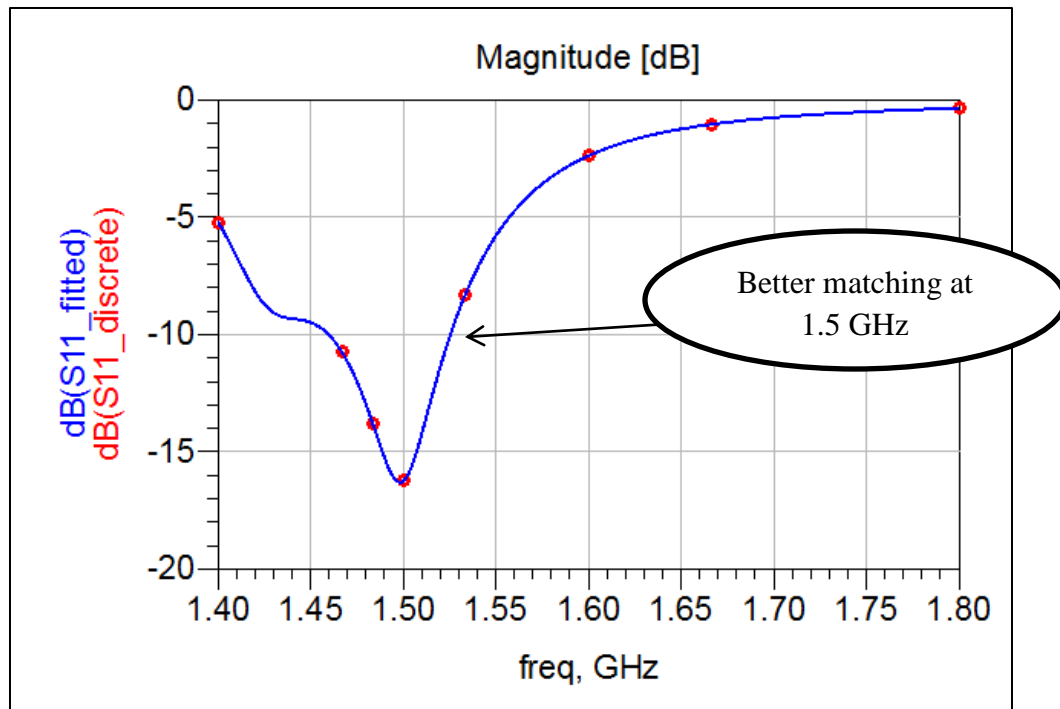

Fig.93 Return loss of the antenna proposed in Fig.92

6.3.3 Inserting another VIA:

Having a VIA to enhance the coupling between the two patches earlier enhanced the return loss of the antenna at the resonant frequency in a great way. Two locations showed promising antenna one is having a VIA to the right of the antenna's center, and the other is having it to the left of the center. Now, if both VIAs were considered in our antenna, then the performance of the antenna is expected to enhance greatly. The main reason for that expectations is that the two antenna showed a good performance without any VIA, and that performance improved once a VIA was considered and the coupling between the two patches increased. As a result, having two VIAs will improve the coupling between the two layers and more surface current will be available on the upper patch. Fig.94, Fig.95 shows the antenna with two VIAs and the return loss of the antenna at the resonant frequency respectively.

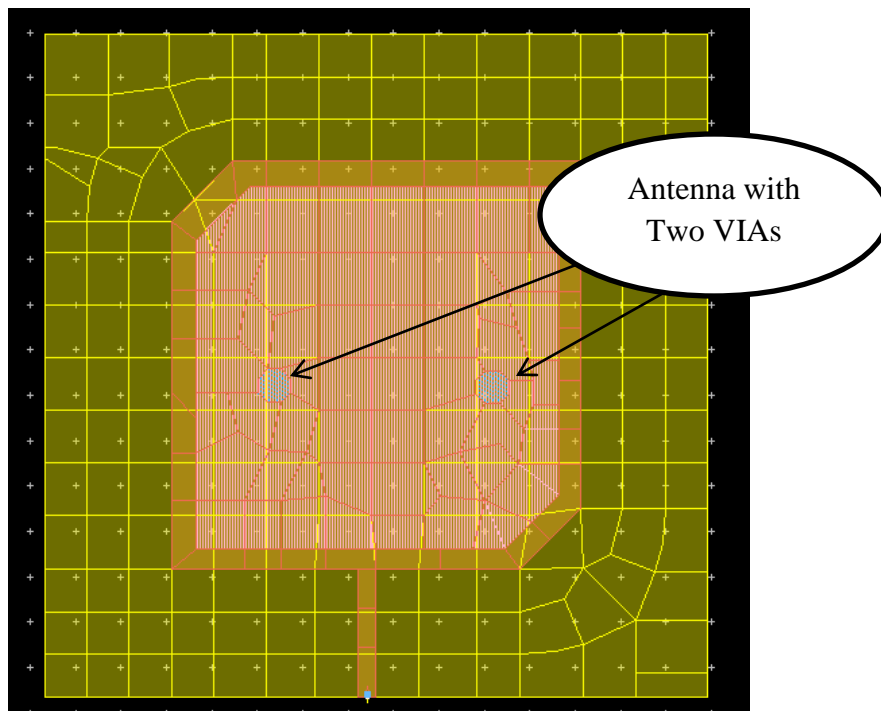

Fig.94 Antenna with two VIAs

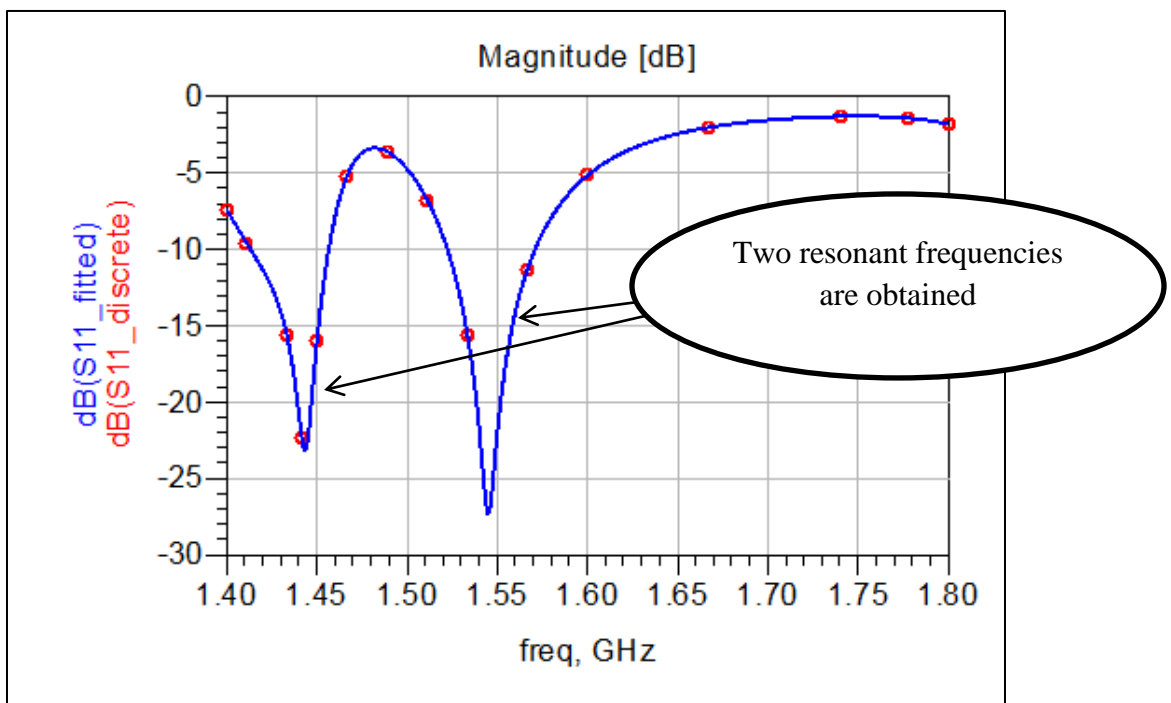

Fig.95 Return loss of the antenna with two VIAs

The results from adding another VIA to the antenna, shows a great matching and wider return loss band width at the resonant frequency. Moreover, another resonant frequency is obtained. Now, there are two resonant frequencies, one at 1.44 GHz and the other at 1.54 GHz. This antenna shows much more promising performance than the one obtained earlier with only one VIA.

6.3.4 Making slot in the upper patch:

One of the well-known techniques to enhance the performance of the antenna at its resonant frequency is to have a slot on the conducting part. Therefore, we made a slot on the upper patch to examine the antenna performance and how the return loss of the antenna will look like. As shown, in Fig.96, and Fig.97, which represents the antenna with a slot and the return loss, having a slot in the upper patch does not a have a great effect on the antenna performance.

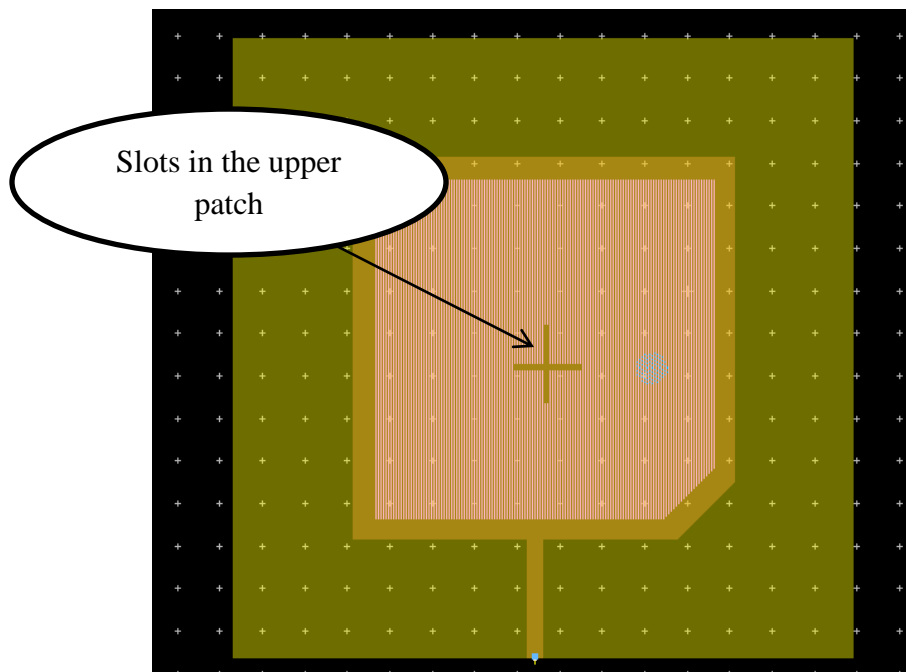

Fig.96 Slots on the upper patch

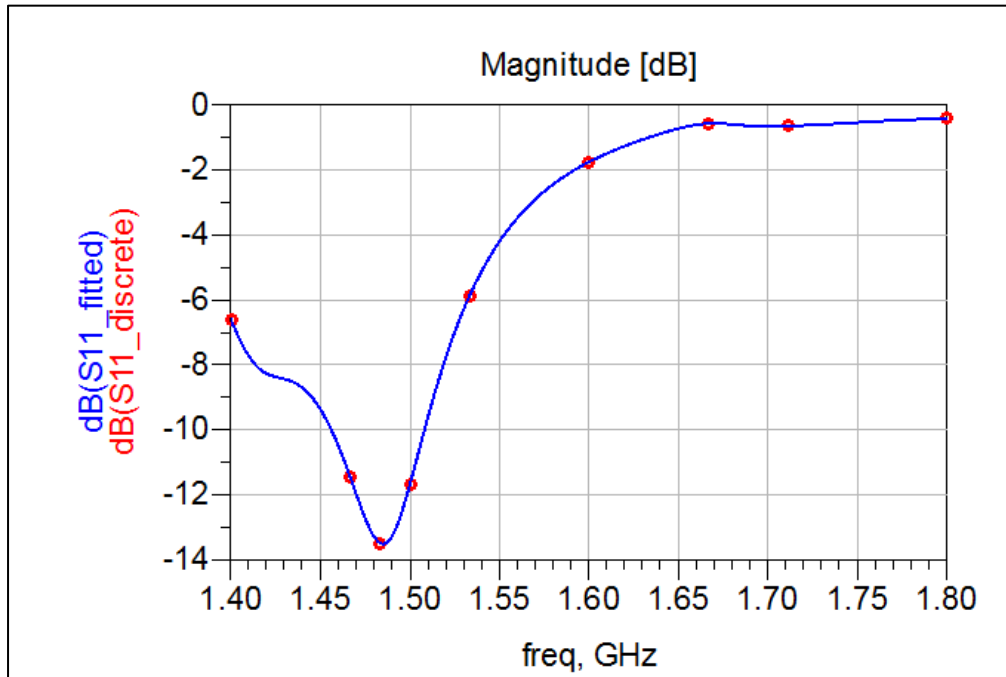

Fig.97 Return loss of the antenna having a lot in upper patch

6.3.5 Changing the upper substrate thickness:

Changing the thickness of the substrate has its effect on the antenna performance usually. By increasing or decreasing the thickness of the substrate the coupling, surface current, radiating elements of the antenna will be affected. In this simulation and technique, the thickness of the upper substrate was changed from 3.2 mm thickness to a 2.5 mm thickness as in Fig.98. The simulations shows different than what was expected that there is no huge difference in the antenna performance, just a minor shift in the antenna return loss band width to the right as in Fig.99.

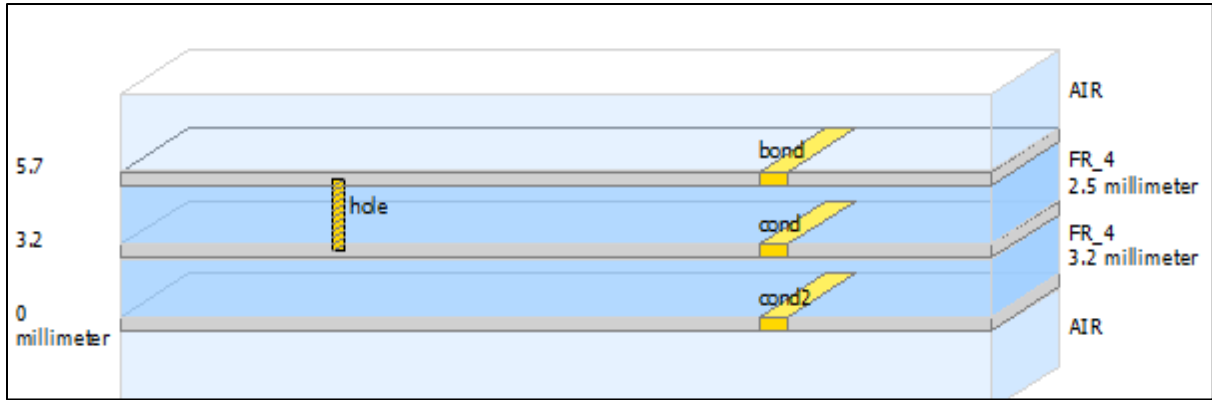

Fig.98 Cross section of the antenna with 2.5 mm upper substrate thickness

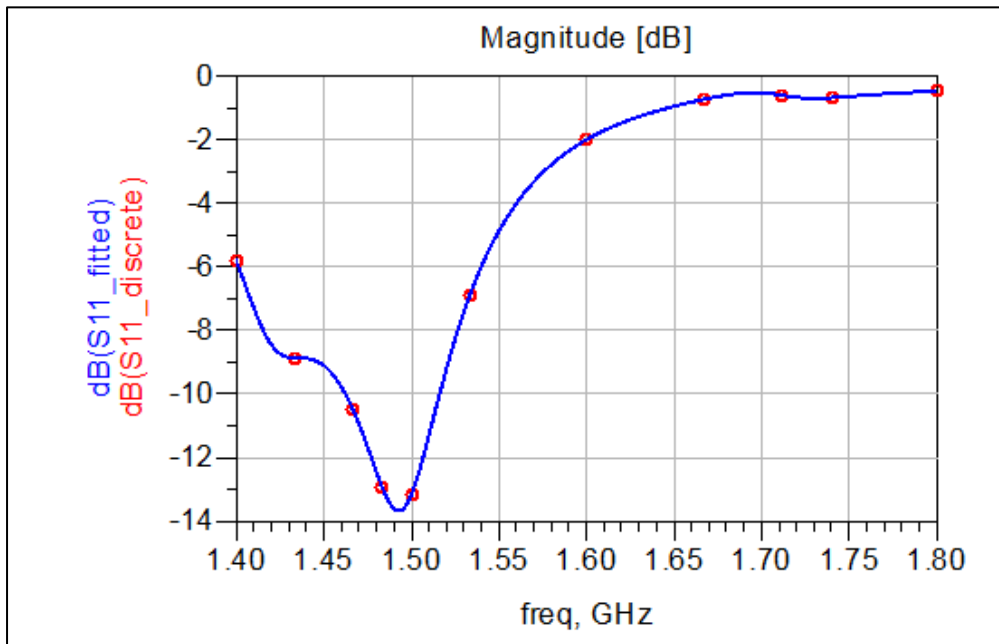

Fig. 99 Return loss of the Antenna in Fig.98

6.3.6 Changing the upper antenna to Helix antenna:

In this technique, the Helix antenna was examined on our upper patch. Basically, the upper patch shape was changed to be a Helix shape as in Fig.100. Helix antennas are very well known for their good performance in terms of the return loss and resonant frequency matching. The performance of the antenna, as it can be seen in Fig.101, proves the principle in mind about the Helix antenna performance in terms of better matching. However, due to its complicated construction, obtaining the circular polarization of the antenna is much more difficult and cannot be done using ADS.

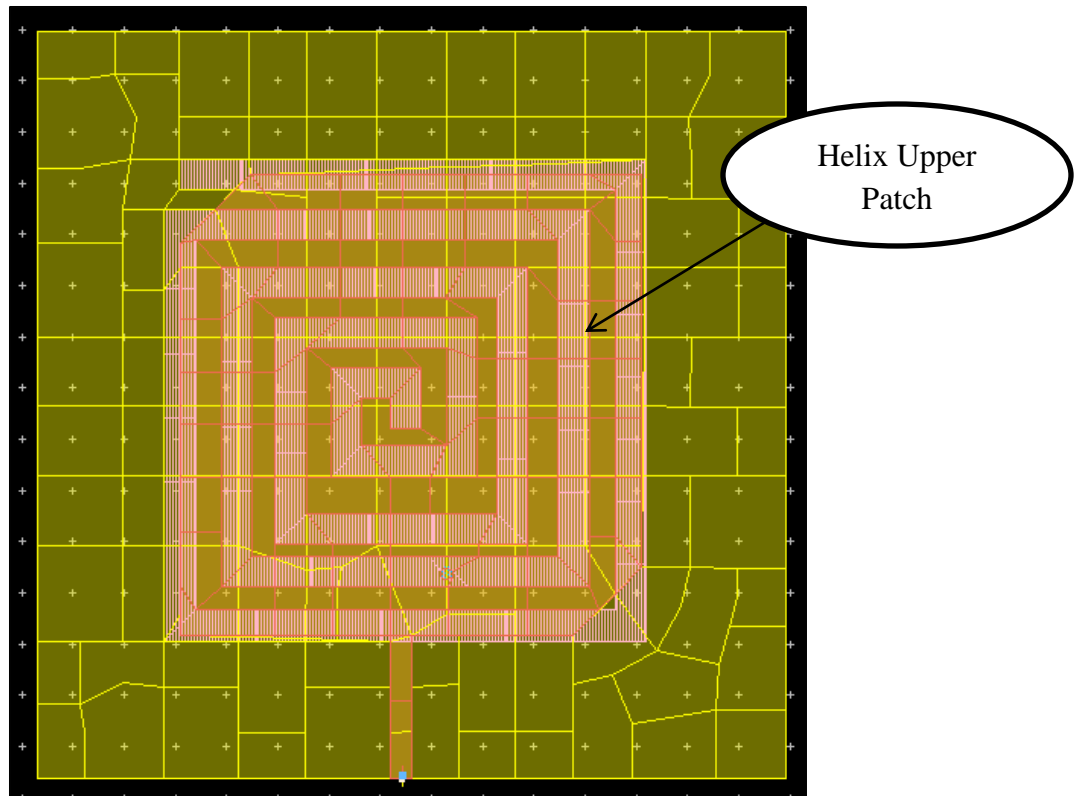

Fig.100 Helix upper patch

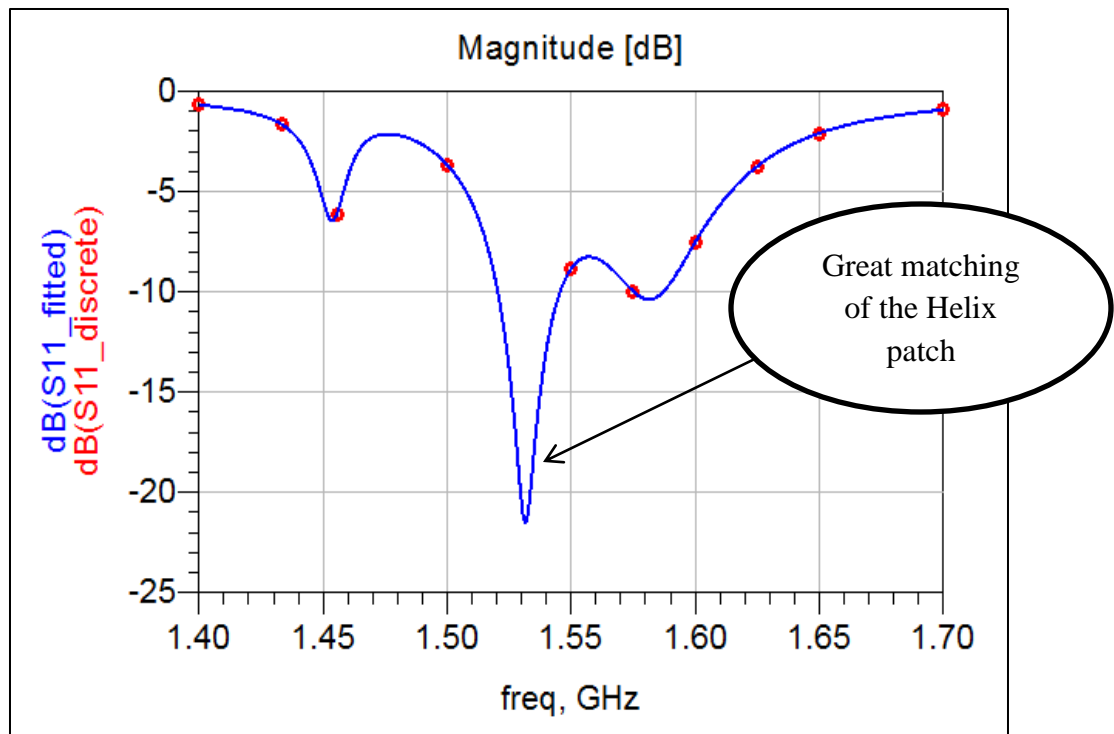

Fig.101 Return Loss of the Helix upper patch at the resonant frequency

From the proceedings, different techniques can have different effects on the designed antenna. Many of these techniques can be adopted in our antenna or a mixture of multiple techniques can be used. However, for the simplicity of the design, easy of construction, and to keep the original formation as it is only one technique was adopted for the final antenna layout. The most effective technique was chosen for our antenna which is the technique of having two VIAs as in Fig.94. This technique has the most effective enhancement on the antenna in terms of the return loss, matching and wider bandwidth. In addition, this technique provided multiple resonant frequencies around our resonant frequency.

Furthermore, this technique was improved by modifying the location of the second added VIA. The other VIA, although it was added along the center line to the left of the center point, was shifted a little bit higher than the center line and lower the center line to check the antenna performance at the resonant frequency in all the cases. Fig.102,103, and 104 represents the return loss of these different second VIA location. From the simulations, the VIA when it is lower than the center line perform much better comparing to the other location in terms of the bandwidth of the operational frequencies. As a result, our final antenna design, as in Fig.105, is chosen with the lower second VIA.

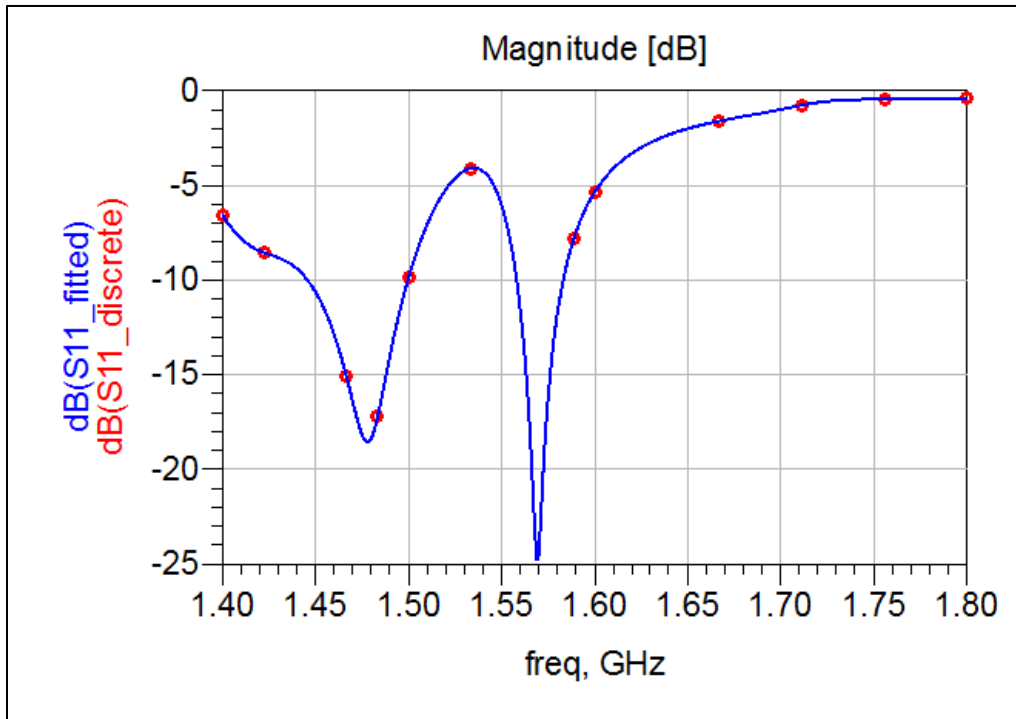

Fig.102 Return Loss of the antenna with 2nd VIA higher than the center line

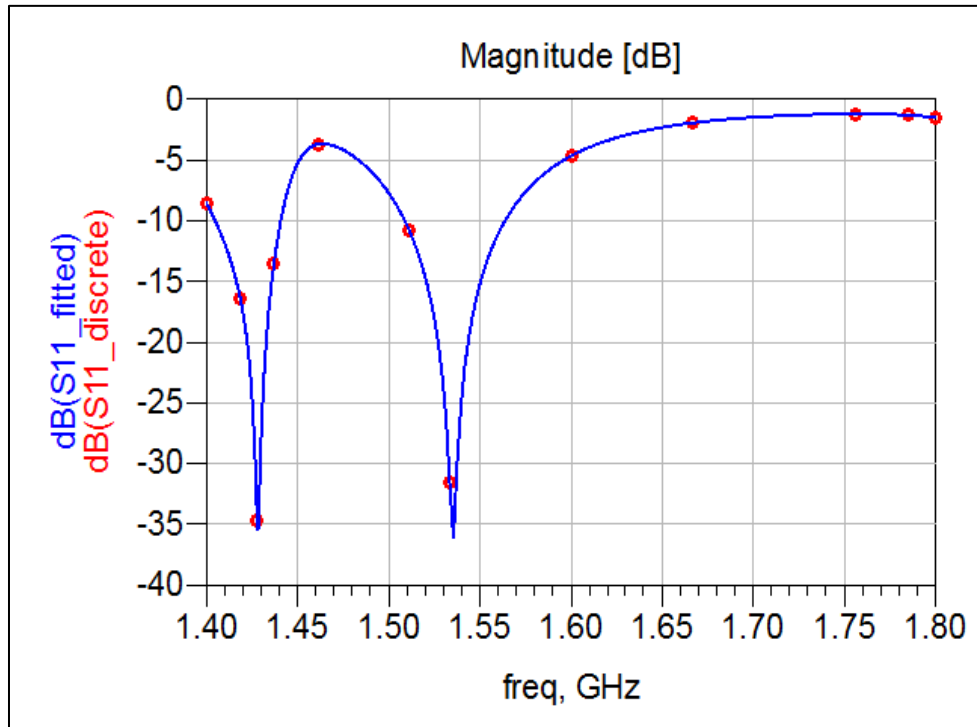

Fig.103 Return Loss of the antenna with 2nd VIA along the center line

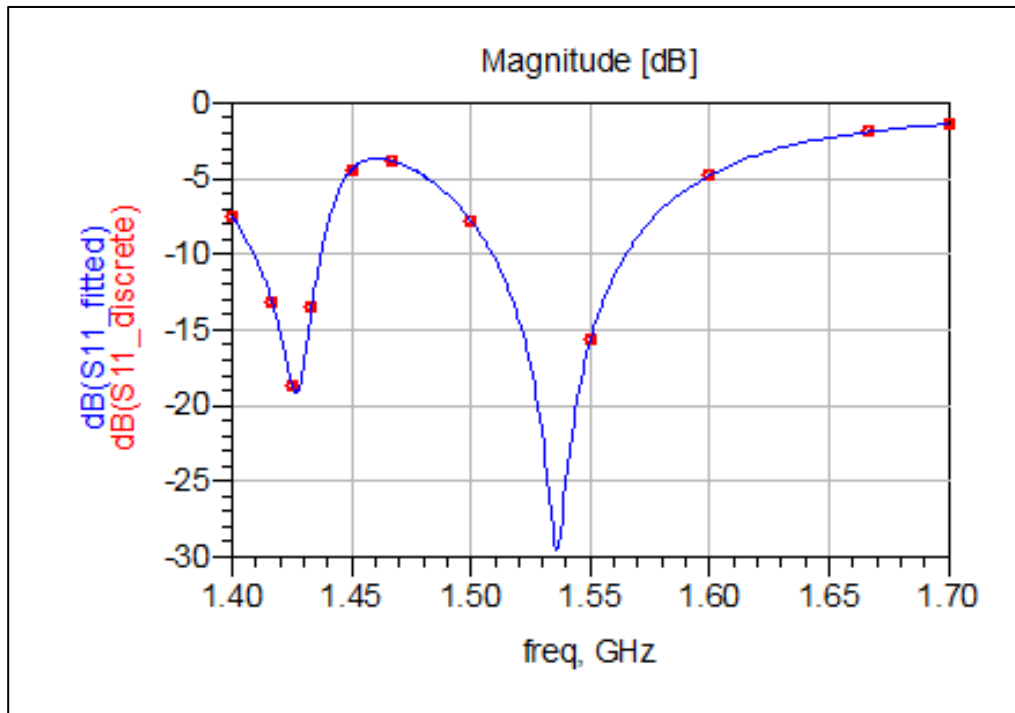

Fig.104 Return Loss of the antenna with 2nd VIA lower than the center line

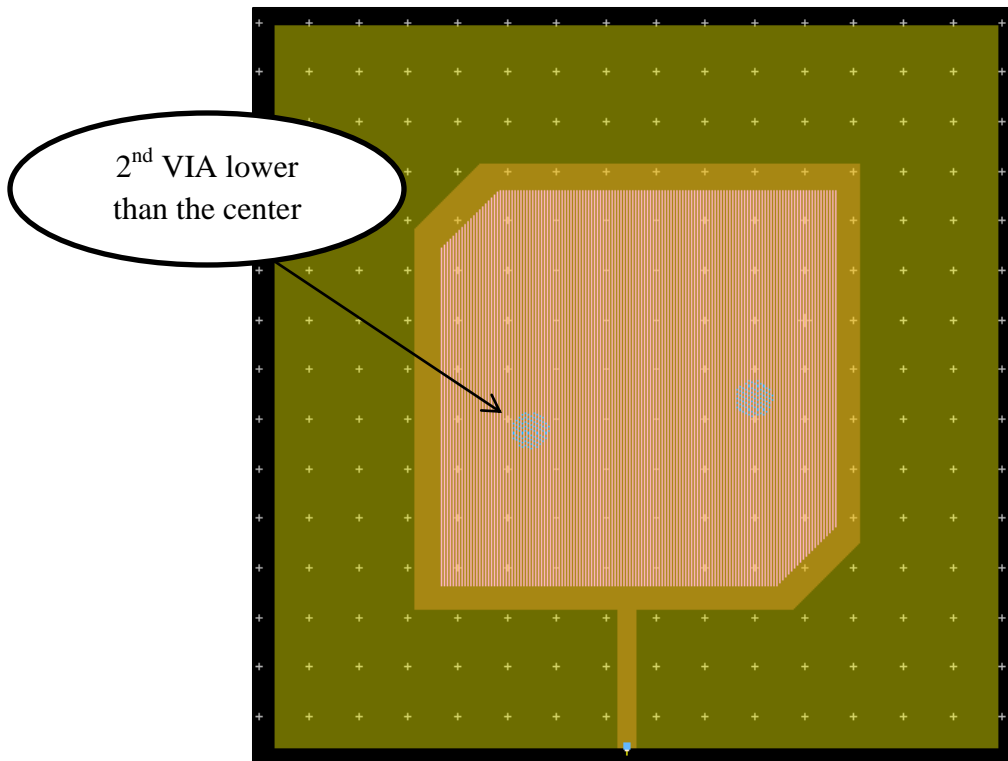

Fig.105 Final Antenna layout with 2nd VIA lower than the center line

6.4 Antenna Final Design:

The final design of our proposed antenna has been finalized and it is presented in this section. Now, the antenna have gone through several modifications that considered all the elements of the antenna design starting from the shape of the antenna, number of substrates, thickness of the substrates, ground plane size, different conducting materials coupling mechanism, Different feeding methods, and different matching improvement techniques. The final antenna design cross section and antenna dimensions is shown in Fig.106 and Fig.107 respectively.

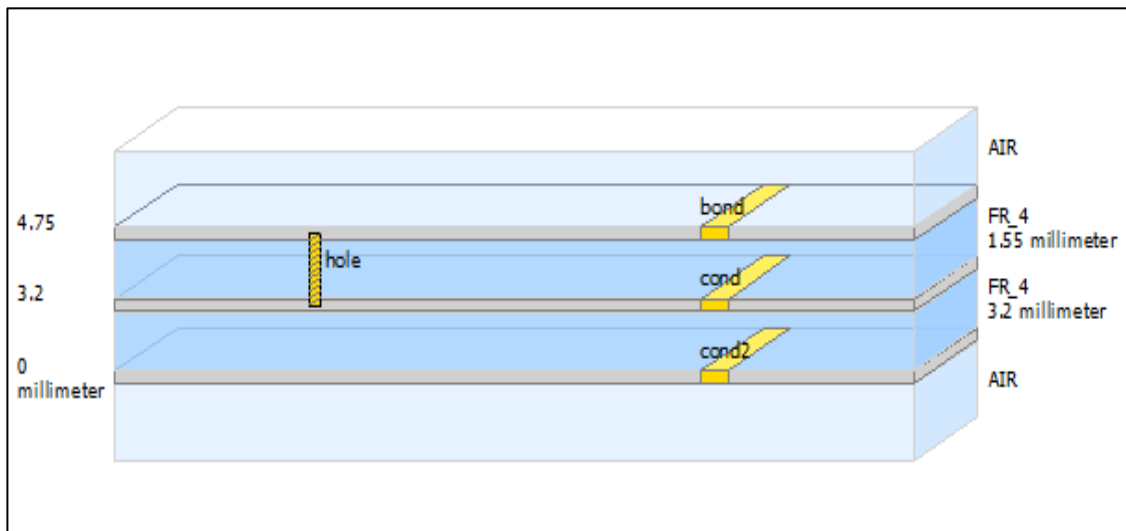

Fig.106 Final Antenna Cross Section

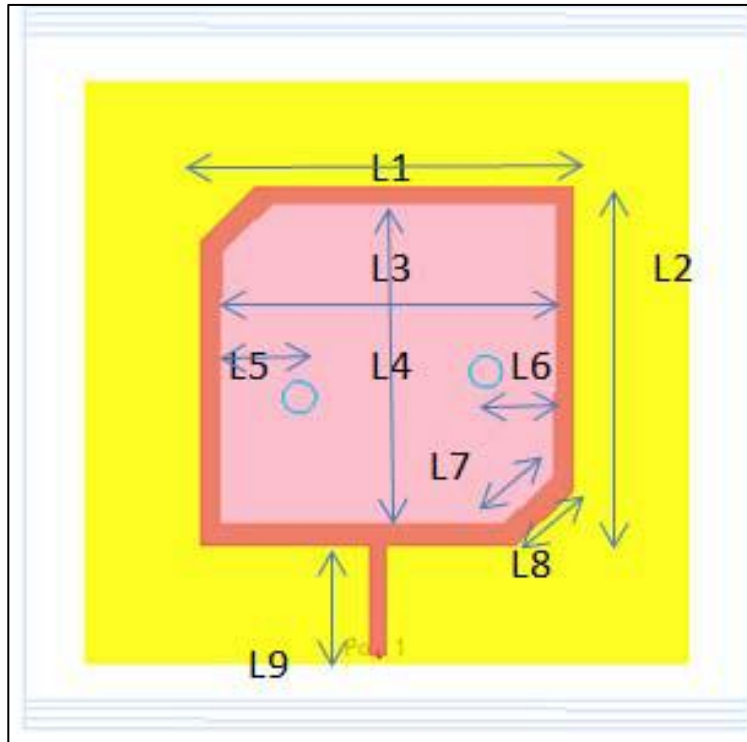

Fig.107 Final Antenna Layout and dimensions

Table.3 shows the final antenna dimensions which is indicated in Fig.107. It is important to mention that the antenna consists of two substrates that are identical of the FR_4 material with permittivity $\epsilon_r = 4.6$. However, the thickness of the two substrates is different where the lower substrate is with thickness 3.2 mm and the upper substrate with thickness 1.55 mm.

Table.3 Final Antenna Dimensions

L1 (mm)	L2 (mm)	L3 (mm)	L4 (mm)	L5 (mm)	L6 (mm)	L7 (mm)	L8 (mm)	L9 (mm)
45	45	40	40	9.2	8	8.5	9.5	14

This antenna was simulated from 1 GHz till 6 GHz to see the performance of the antenna at different frequency range in terms of resonant frequencies and return loss. The results obtained as in Fig.108, and 109 show the antenna has a good matching at multiple frequency bands. As long as the Satellite communications is considered, the antenna showed good performance around 1.5 GHz which is our desired frequency for common satellite communications. The antenna showed good matching at around two frequencies that can be utilized for satellite communications which are 1.487 GHz and 1.578 GHz.

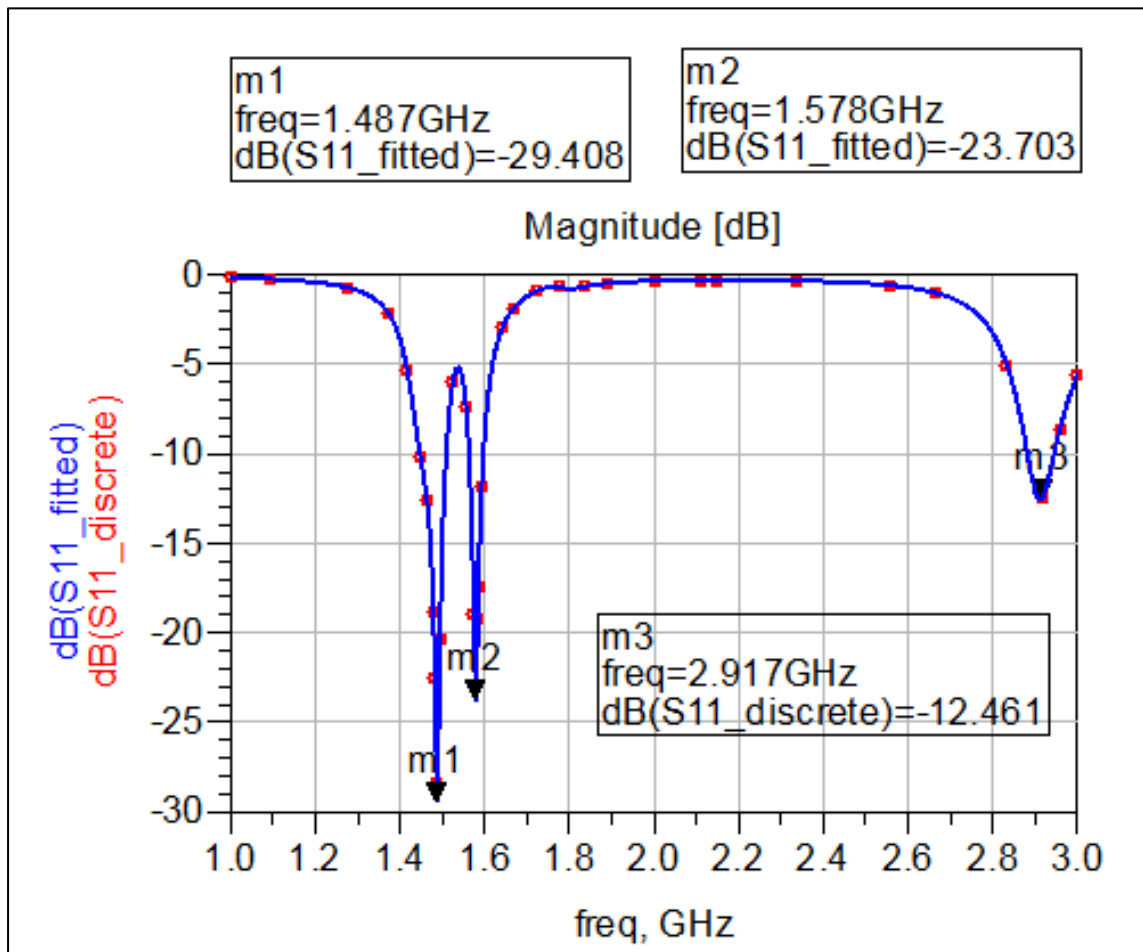

Fig.108 Return loss of the Final Antenna from 1 GHz to 3GHz

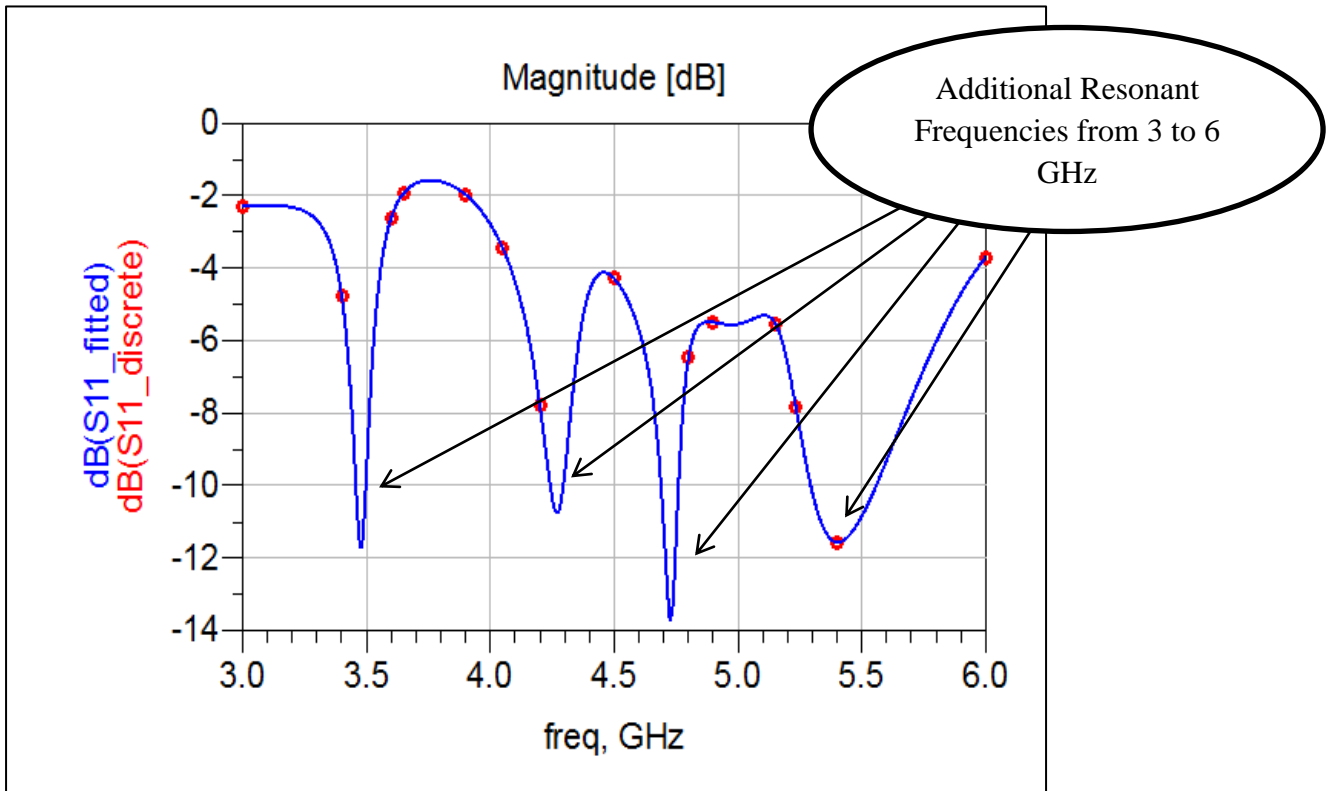

Fig.109 Return loss from 3 GHz till 6 GHz

Moreover, the antenna has a good matching at different resonant frequencies that can be utilized for different communication purposes at 2.917 GHz, 3 GHz, 4.3 GHz, 4.7 GHz, and 5.4 GHz. Furthermore, the polarization of the antenna is measured through the Axial Ratio at the desired frequencies. When the radiation pattern has 0 dB as axial ratio, then the antenna is having a circular polarization pattern. However, for practical designs and applications, 3 dB is considered acceptable limit for the antenna radiation pattern to be considered as a circularly polarized at a certain frequency band. Circular polarization is achieved around the band from 1.453 GHz to 1.478 GHz with approximately 25 MHz band width as presented in Fig.110. On the other hand, there is no circular polarization is achieved around 1.578 GHz, which requires further modifications and enhancements in order to be achieved.

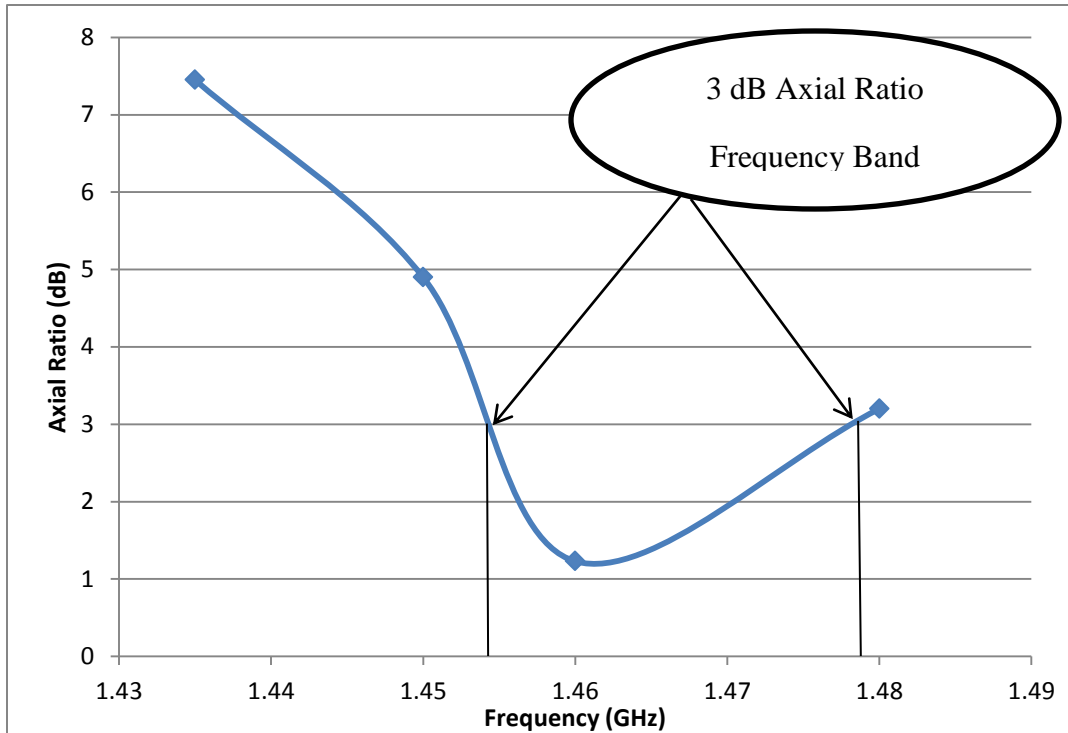

Fig.110 Axial Ratio of the Final Antenna Vs. Frequency

In addition to the above, the designed antenna shows a good performance in terms of the radiation pattern, as in Fig.111, since the antenna has an omni-directional radiation pattern. A gain of 3.42 dBi was achieved at 1.487 GHz. The bandwidth around these two frequency bands is from 1.45 GHz to 1.51 GHz for 1.487 GHz center frequency and 1.57 GHz to 1.61 GHz for the 1.578 GHz center frequency. Moreover, as in Fig.112 and Fig.113, the surface current on the upper patch is much better than the earlier antenna with single VIA.

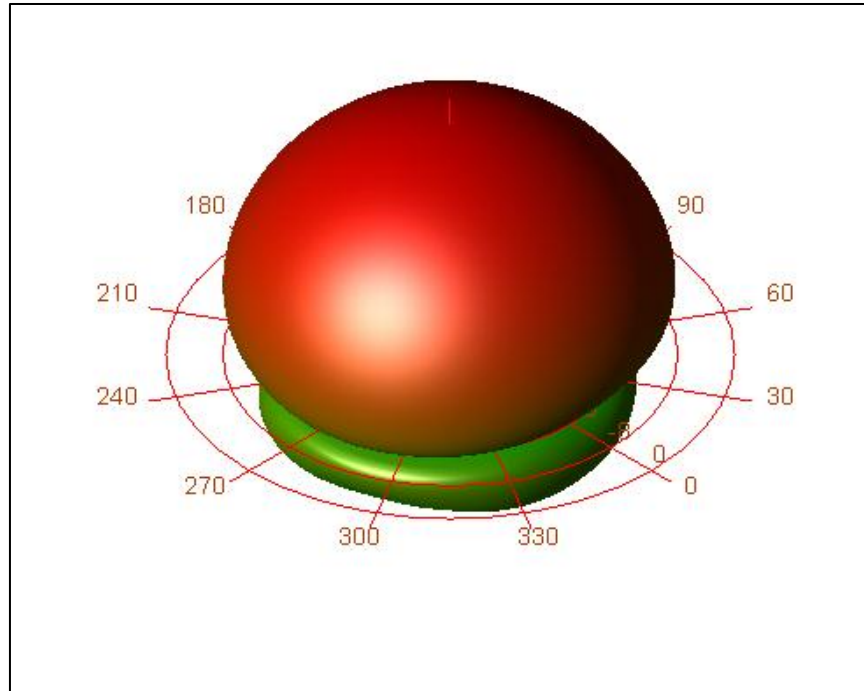

Fig.111 Radiation Pattern of the Final Antenna at 1.487 GHz

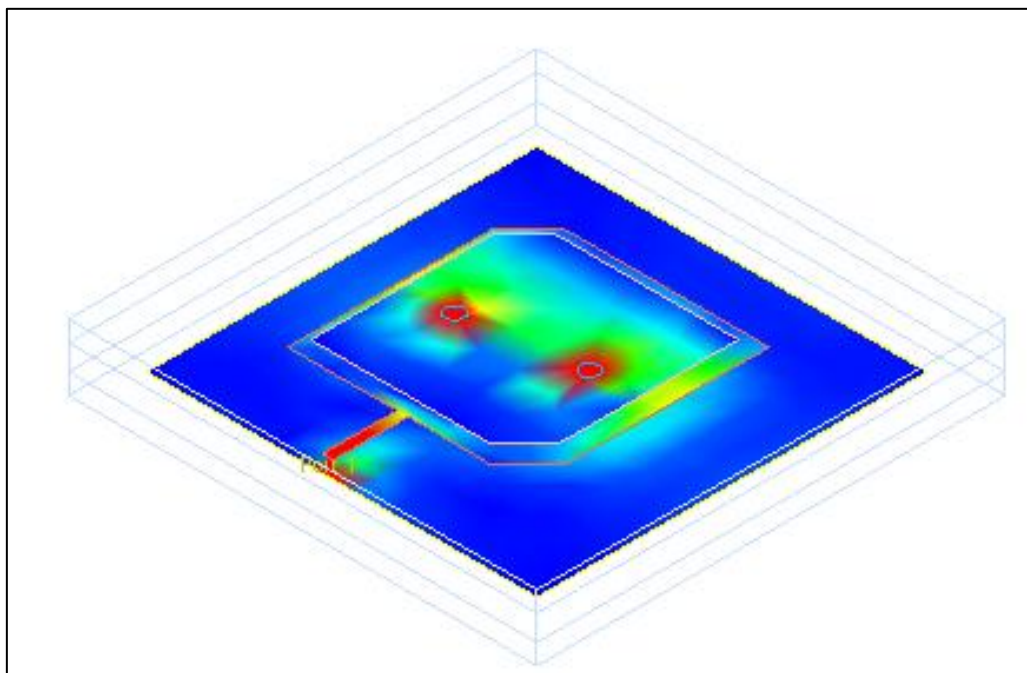

Fig.112 Surface current on top of the upper patch of the Final Antenna at 1.487 GHz

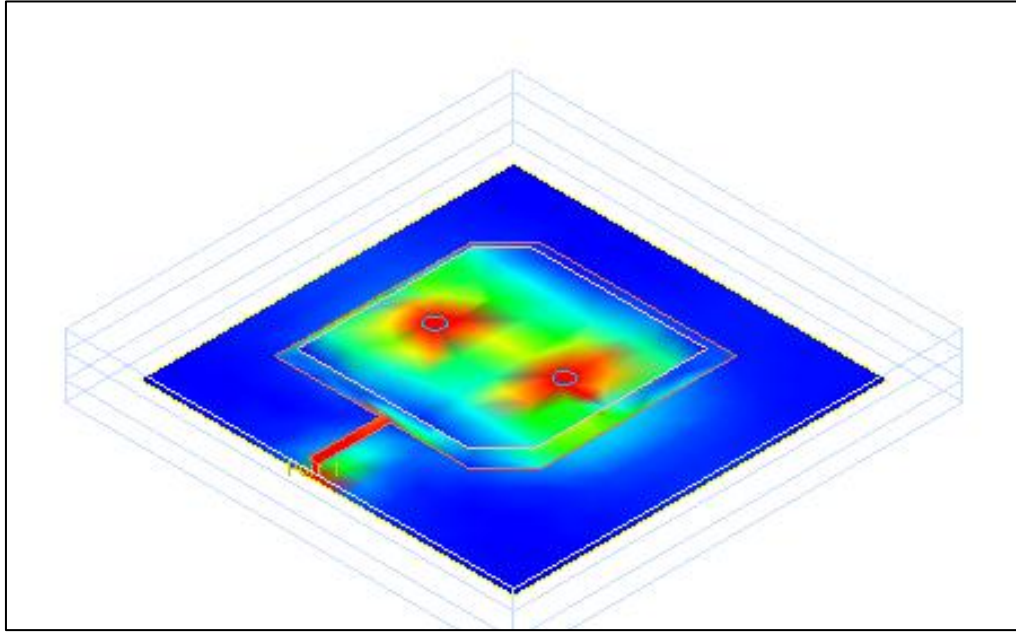

Fig.113 Surface current on top of the upper patch of the Final Antenna at 1.578 GHz

The designed antenna shows a good potential to be utilized for satellite communications. Moreover, having many other frequency bands, gives the antenna the advantage of being used in other applications as well. This antenna, even though, it has a good matching bandwidth around the desired resonant frequency and a Circular Polarization, but it requires further enhancements and modifications in order to have even wider CP bandwidth. Many techniques were presented and applied to the antenna to enhance the antenna performance in terms of the resonant frequencies and CP bandwidths. However, one of the main goals of this design is to maintain the structure of the antenna to be simple, easy to fabricate, and to utilize available materials.

In order to assess the final antenna design, it is important to compare between the antenna output parameters at different stages of the design. Table.4 summarizes the different parameters of the antenna obtained over the different design stages.

Table.4 Designed Antenna Parameters at different design stages

Design Stage	Rectangular antenna as in Fig.65	Square antenna as in Fig.67	Square antenna with corner cuts as in Fig.71	Proposed antenna with one VIA as in Fig.85	Final Antenna Design as in Fig.107
Center Frequency	1.65 GHz but Return loss is not 10dB or less	1.75 GHz but Return loss is not 10dB or less	1.6 GHz	1.48 as in Fig.87	At 1.487 GHz and 1.578 GHz
Bandwidth	No matching as in Fig.66	No matching as in Fig.68	From 1.58GHz to 1.61GHz	From 1.45GHz to 1.51 as in Fig.87	From 1.45 GHz to 1.51 GHz, and 1.57 GHz to 1.61 GHz
AR Bandwidth (with CP)	No CP	No CP	From 1.53GHz to 1.555GHz as in Fig.75	From 1.445GHz to 1.47GHz	1.453 GHz to 1.478 GHz
Gain (at 1.5 GHz)	0.38 dBi	0.35 dBi	2.25 dBi	2.45 dBi	3.42 dBi at 1.487 GHz
Other Frequency Bands (from 0 to 6 GHz)	at 2.58GHz, 4.7GHz, and 5.1GHz	at 4.25GHz as in Fig.68	at 3GHz, and 5.8GHz	at 3GHz, 4.4GHz, and 5.6GHz	at 2.917GHz, 3GHz, 4.3GHz, 4.7GHz, and 5.4GHz

From Table.4 and as the design started from scratch following Balanis theories in [2], the final antenna design much more better serving the main purpose of this research. All the parameters concerning the center frequency of the study have been developed like the bandwidth, CP bandwidth, gain, and number of center frequencies that can be utilized for both downlink and uplink. Moreover, many other frequencies were obtained that can be used for other communication systems.

Chapter VII

Conclusions and further work

A circularly polarized stacked microstrip patch antenna has been designed that is suitable for satellite communications. The proposed antenna was simulated using ADS software. Simulation results show good impedance matching and return loss around two main center frequencies of satellite communication which are 1.487 GHz and 1.578 GHz. Moreover, a good matching and return loss bandwidth is achieved around these two center frequencies. Furthermore, circular polarization is achieved to satisfy the polarization requirements satellite communication antennas. The designed antenna provides good omnidirectional radiation pattern and a reasonable gain.

The designed antenna has many other matching frequency bands that can be utilized in other communication systems. The antenna is easy to fabricate, built and integrate with other electronic circuits. In addition, the antenna is compact in size and it is built using available materials for both the conductors and substrates.

In the future work, further modifications to this antenna shall be considered in terms of having other frequency bands that is used in the normal urban communication infrastructure. This is to allow the handheld devices' manufacturers to develop devices that can be used for both communication systems. Finally, since the designed antenna is considering Thuraya Satellite Company frequency bands as a case study, the antenna needs to be enhanced to be a tunable antenna that can serve other satellite communication frequency bands being used by other companies.

References

- [1] B. Miller, "Satellites free the mobile phone," in *IEEE Spectrum*, vol. 35, no. 3, pp. 26-35, March 1998.
- [2] Balanis, Constantine A. *Antenna Theory: Analysis and Design*. Third ed. Hoboken, NJ: Wiley Interscience, 2005.
- [3] B. Naimian and M. H. Neshati, "A new novel dual-band circularly-polarized microstrip antenna," *2011 19th Iranian Conference on Electrical Engineering*, Tehran, 2011, pp. 1-4.
- [4] D. V. N. Méndez, L. F. C. Suárez and M. B. Escudero, "Circular polarization patch antenna with low axial ratio in a large beamwidth," *Antennas and Propagation (EuCAP), 2013 7th European Conference on*, Gothenburg, 2013, pp. 3330-3333.
- [5] T. C. Yo, C. M. Lee and C. H. Luo, "Small Single Band Circular Polarization and Dual Band Circular Patch Antenna," *2007 International workshop on Antenna Technology: Small and Smart Antennas Metamaterials and Applications*, Cambridge, 2007, pp. 435-438.
- [6] Gui-Bin Hsieh, Ming-Huang Chen and Kin-Lu Wong, "Single-feed dual-band circularly polarised microstrip antenna," in *Electronics Letters*, vol. 34, no. 12, pp. 1170-1171, 11 Jun 1998.
- [7] Bin Luo, Jianhua Li and Yiqiang Wu, "A convenient method to design dual-frequency circular-polarization patch antenna," *Microwave and Millimeter Wave Technology, 2008. ICMWT 2008. International Conference on*, Nanjing, 2008, pp. 1841-1844.
- [8] R. B. Waterhouse, "Stacked patches using high and low dielectric constant material combinations," in *IEEE Transactions on Antennas and Propagation*, vol. 47, no. 12, pp. 1767-1771, Dec 1999.
- [9] Nasimuddin, X. Qing and Z. N. Chen, "Microstrip antenna with S-shaped slot for dual-band circularly polarized operation," *Microwave Conference, 2009. EuMC 2009. European*, Rome, 2009, pp. 381-384.
- [10] N. Herscovici, Z. Sipus and D. Bonefacic, "Circularly polarized single-fed wide-band microstrip patch," in *IEEE Transactions on Antennas and Propagation*, vol. 51, no. 6, pp. 1277-1280, June 2003.
- [11] Nasimuddin, K. P. Esselle and A. K. Verma, "Wideband Circularly Polarized Stacked Microstrip Antennas," in *IEEE Antennas and Wireless Propagation Letters*, vol. 6, no. , pp. 21-24, 2007.

- [12] Ye Jianfeng, Pang Weizheng, Wang Yufeng, Lv Daxin and Chen Yan, "Optimized design of circularly polarized wideband stacked microstrip antenna with single-fed," *Microwave and Millimeter Wave Technology, 2008. ICMMT 2008. International Conference on*, Nanjing, 2008, pp. 1651-1653.
- [13] D. Liu, J. Miao and X. Zhao, "A Triple-band Circular Polarization Stacked Microstrip Antenna," *Microwave, Antenna, Propagation and EMC Technologies for Wireless Communications, 2007 International Symposium on*, Hangzhou, 2007, pp. 559-562.
- [14] W. J. Krzysztofik, "Double Semi-Rings Patch Antenna," *Antennas and Propagation, 2007. EuCAP 2007. The Second European Conference on*, Edinburgh, 2007, pp. 1-6.
- [15] Nasimuddin, K. Esselle and A. K. Verma, "High Gain Compact Circularly Polarized Microstrip Antenna," *TENCON 2005 - 2005 IEEE Region 10 Conference*, Melbourne, Qld., 2005, pp. 1-4.
- [16] M. Yahya and Z. Awang, "Cross polarization ratio analysis of circular polarized patch antenna," *Electromagnetics in Advanced Applications (ICEAA), 2010 International Conference on*, Sydney, NSW, 2010, pp. 442-445.
- [17] S. Sainkar and A. Jeyakumar, "Design analysis and testing of broadband circularly polarized compact microstrip antenna for wireless applications," *Signal Processing, Communication, Computing and Networking Technologies (ICSCCN), 2011 International Conference on*, Thuckafay, 2011, pp. 70-75.
- [18] S. Kaffash and M. Kamyab, "A sequentially rotated RHCP stacked patch antenna array for INMARSAT-M land applications," *2012 6th European Conference on Antennas and Propagation (EUCAP)*, Prague, 2012, pp. 1-4.
- [19] W. J. Krzysztofik, K. Kurowski and Z. Langowski, "Stacked rectangular ring antenna for GPS mobile receiver," *Antennas and Propagation, 1993., Eighth International Conference on*, Edinburgh, 1993, pp. 194-197 vol.1.
- [20] Lei Zhu, I. Joishi and E. Yamashita, "Theoretical and experimental studies on the microstrip-fed inverted patch antenna with linear or circular polarization," *Antennas and Propagation Society International Symposium, 1996. AP-S. Digest*, Baltimore, MD, USA, 1996, pp. 1556-1559 vol.3.
- [21] Hyungrak Kim, Byoung Moo Lee and Young Joong Yoon, "A single-feeding circularly polarized microstrip antenna with the effect of hybrid feeding," in *IEEE Antennas and Wireless Propagation Letters*, vol. 2, no. 1, pp. 74-77, 2003.

- [22] X. Zhang and M. Y. Xia, "A broadband circular polarization patch antenna with differential-feeding," *Microwave Technology and Computational Electromagnetics, 2009. ICMTCE. International Conference on*, Beijing, 2009, pp. 109-112.
- [23] N. Herscovici, Z. Sipus and D. Bonefacic, "Circularly polarized single-fed microstrip patch for wireless communications," *Antennas and Propagation for Wireless Communications, 1998. 1998 IEEE-APS Conference on*, Waltham, MA, 1998, pp. 167-170.
- [24] N. Bayatmaku, P. Lotfi, M. Azarmanesh and S. Soltani, "Design of Simple Multiband Patch Antenna for Mobile Communication Applications Using New E-Shape Fractal," in *IEEE Antennas and Wireless Propagation Letters*, vol. 10, no. , pp. 873-875, 2011.
- [25] A. K. Arya, M. V. Kartikeyan and A. Patnaik, "Efficiency enhancement of microstrip patch antenna with defected ground structure," *Recent Advances in Microwave Theory and Applications, 2008. MICROWAVE 2008. International Conference on*, Jaipur, 2008, pp. 729-731.
- [26] A. K. Arya, A. Patnaik and M. V. Kartikeyan, "A compact array with low mutual coupling using defected ground structures," *Applied Electromagnetics Conference (AEMC), 2011 IEEE*, Kolkata, 2011, pp. 1-4.
- [27] Nasimuddin, K. P. Esselle and A. K. Verma, "Study of various Slots in Circular Patch for Circularly Polarized Antennas and Enhancing their Gain by Short Horns," *2006 Asia-Pacific Microwave Conference*, Yokohama, 2006, pp. 1519-1522.
- [28] J. R. Panda, R. S. Kshetrimayum and A. S. R. Saladi, "An inset-fed dual-frequency circular microstrip antenna with a rectangular slot for application in wireless communication," *2011 International Conference on Emerging Trends in Electrical and Computer Technology*, Nagercoil, 2011, pp. 976-981.