

Rochester Institute of Technology

## RIT Digital Institutional Repository

---

Theses

---

10-2017

### Pitch Control of Wind Turbine through PID, Fuzzy and adaptive Fuzzy-PID controllers

Silpa Baburajan  
sxb3059@rit.edu

Follow this and additional works at: <https://repository.rit.edu/theses>

---

#### Recommended Citation

Baburajan, Silpa, "Pitch Control of Wind Turbine through PID, Fuzzy and adaptive Fuzzy-PID controllers" (2017). Thesis. Rochester Institute of Technology. Accessed from

This Thesis is brought to you for free and open access by the RIT Libraries. For more information, please contact [repository@rit.edu](mailto:repository@rit.edu).

# Pitch Control of Wind Turbine through PID, Fuzzy and adaptive Fuzzy-PID controllers

By

**Silpa Baburajan**

A Thesis Submitted in Partial Fulfilment of the Requirements for the Degree of  
**Master of Science in Electrical Engineering**

Supervised by  
**Dr. Abdulla Ismail**

Department of Electrical Engineering  
Kate Gleason College of Engineering  
Rochester Institute of Technology  
Rochester, NY  
October 2017

**Approved By:**

**Date:**

---

Dr. Abdulla Ismail

*Thesis Advisor – Department of Electrical Engineering*

**Date:**

---

Dr. Ghalib Kahwaji

*Department Chair & Professor- Department of Mechanical Engineering*

**Date:**

---

Dr. Ziad Elkhatib

*Assistant Professor – Department of of Electrical Engineering*

*To my beloved parents Dr.P.K. Baburajan, Mrs. Uma Devi Baburajan and my dearest  
brother Sarath Baburajan*

## **Acknowledgement**

I take this opportunity to express my profound gratitude and deep regards to my primary advisor Dr. Abdulla Ismail for his exemplary guidance, monitoring and constant encouragement throughout this thesis. Dr. Ghalib Kahwaji and Dr. Ziad Elkhatib dedicated his valuable time to review my work and provide valuable suggestions which helped me in improving the quality of my thesis. I also take this opportunity to thank my parents, brother and all my friends for all the constant support and help provided by them.

## **Declaration**

I hereby declare that this thesis represents my original work and all used references are properly cited

---

Silpa Baburajan

## **Papers Published from the Thesis**

- [1] S. Baburajan and A. Ismail, "PID Control of Wind Turbine Pitch System", *International Research Journal of Engineering and Technology (IRJET)*, vol. 4, no. 9, 2017.
- [2] S. Baburajan and A. Ismail, "Modelling and Fuzzy Logic Control of Wind Turbine Pitch System ", *International Research Journal of Engineering and Technology (IRJET)*, vol. 4, no. 9, 2017.
- [3] S. Baburajan and A. Ismail, " Wind Turbine Pitch Control using Adaptive Fuzzy-PID Controller", *International Research Journal of Engineering and Technology (IRJET)*, vol. 4, no. 9, 2017.

## **Abstract**

As the penetration of the wind energy into the electrical power grid is extensively increased, the influence of the wind turbine systems on the frequency and voltage stability becomes more and more significant. Wind turbine rotor bears different types of loads; aerodynamic loads, gravitational loads and centrifugal loads. These loads cause fatigue and vibration in blades, which cause degradation to the rotor blades. These loads can be overcome and the amount of collected power can be controlled using a good pitch controller (PC) which will tune the attack angle of a wind turbine rotor blade into or out of the wind. Each blade is exposed to different loads due to the variation of the wind speed across the rotor blades. For this reason, individual electric drives can be used in future to control the pitch of the blades in a process called Individual Pitch Control. In this thesis work, an enhanced pitch angle control strategy based on fuzzy logic control is proposed to cope with the nonlinear characteristics of wind turbine as well as to reduce the loads on the blades. A mathematical model of wind turbine (pitch control system) is developed and is tested with three controllers -PID, Fuzzy, and Adaptive Fuzzy-PID. After comparing all the three proposed strategies, the simulation results show that the Adaptive Fuzzy-PID controller has the best performance as it regulates the pitch system as well as the disturbances and uncertain factors associated with the system.

# Table of Contents

Title Page .....	1
Acknowledgement .....	3
Declaration .....	4
Papers Published from the Thesis .....	5
Abstract .....	6
List of Tables .....	9
List of Figures .....	10
Glossary .....	11
Chapter 1- Introduction.....	12
1.1 Background .....	12
1.2 Motivation .....	14
1.3 Problem Statement/Research Questions .....	14
1.4 Thesis Outline .....	15
Chapter 2- Literature Review.....	17
2.1 Wind Turbine .....	17
2.2 Types of Wind Turbine.....	18
2.2.1. Fixed Speed WTGs .....	18
2.1.2 Variable Speed WTGs .....	19
2.3 Control Techniques of Wind Turbine System .....	21
Chapter 3 -Mathematical Model of Wind Turbine .....	23
3.1 Physics of Wind Turbine .....	23
3.2 Power Curve Characteristics.....	23
3.3 Relationship between Power Coefficient $C_p$ and the Tip Speed Ratio $\lambda$ .....	26
3.5 Pitch Angle Control .....	27
3.6 Modelling of the Wind Turbine System .....	29
3.6.1 Pitch Actuator Model.....	29
3.6.1 Drive Terrain Model .....	31
Chapter 4- Pitch Angle Controllers for Wind Turbine .....	33
4.1 PID Controller.....	34
4.2 Tuning of the PID Parameters.....	35
4.3 Overview of Fuzzy Control .....	37
4.3.1. Fuzzification .....	37
4.3.2 Fuzzy Rule Base .....	39



4.3.3 Defuzzification.....	40
Chapter 5- Simulation of the Controllers and Results .....	42
5.1 Simulation of the Plant without Controllers .....	42
5.2 Implementation of Conventional PID Controller .....	43
5.3 Simulation of the Plant with PID Controller.....	44
5.4 Implementation of Fuzzy Logic Controller .....	45
5.5 Simulation of the Plant with Fuzzy Controller .....	50
5.6 Implementation of Fuzzy Adaptive PID Controller.....	51
5.7 Simulation of the Plant with an Adaptive Fuzzy-PID Controller .....	53
5.8 Comparison of Simulation Results of the Plant using PID, Fuzzy and an Adaptive Fuzzy-PID Controller.....	54
Chapter 6- Conclusion and Future Works .....	56
References.....	57
Appendix-MATLAB Codes.....	60
Code for plotting the Relationship between wind velocity and power of wind.....	60
Code of Weibull distribution plot between wind velocity and probability.....	60
Code showing the effect of the pitch angle on the output power.....	61

## List of Tables

Table 1:Parameters of Wind Turbine.....	30
Table 2:Mechanical Model Parameters of Drive Train .....	31
Table 3: Fuzzy Rules for $K_p$ .....	39
Table 4: Fuzzy Rules for $K_i$ .....	39
Table 5: Fuzzy Rules for $K_d$ .....	40
Table 6: Time Domain Specification for Unit step Input without Controller.....	43
Table 7:Time Domain Specification for Unit step Input with PID Controller .....	45
Table 8:Time Domain Specification for Unit step Input with Fuzzy Controller .....	50
Table 9:Time Domain Specification for Unit step Input with an Adaptive Fuzzy-PID Controller .....	53
Table 10:Comparison of Time Domain Specifications of Pitch Control System for Unit Step Input Using .....	55

## List of Figures

Figure 1.1: Illustrating the Principal of Betz Law .....	13
Figure 2.1: Inside of A Wind Turbine .....	14
Figure 2.2: Fixed speed wind turbine generator .....	17
Figure 2.3: Variable speed wind turbine generators; (a) with synchronous generator, (b) with DFIG (asynchronous generator) .....	18
Figure 3.1: Power Curve Characteristics of a Wind Turbine.....	22
Figure 3.2: Weibull distribution plot between wind velocity and probability for a site which has a mean wind speed of 7 m/s.....	23
Figure 3.3: The relationship between the $C_p$ and $\lambda$ .....	25
Figure 3.4: Effect of the pitch angle on the output power .....	26
Figure 3.5: Wind Turbine System Feedback Control System Model.....	27
Figure 3.6: Mechanical model of drive train .....	29
Figure 4.1: Principle Diagram of PID Controller .....	32
Figure 4.2: Unity Feedback System.....	32
Figure 4.3. Reading off the time between the first overshoot and the first undershoot .....	34
Figure 4.4: Membership Function Plots for Inputs 'e' and 'ec'.....	36
Figure 4.5: Membership Function Plots for Outputs .....	36
Figure 4.6: Fuzzy Adaptive PID Control Block of Pitch System.....	39
Figure 5.1: Simulink Wind Turbine Model without Controllers .....	39
Figure 5.2: The unit step response of wind turbine without controllers .....	40
Figure 5.3: Simulation diagram of conventional PID controller for pitch control .....	41
Figure 5.4: PID Controller Parameters .....	41
Figure 5.5: The unit step response of wind turbine with PID controller.....	42
Figure 5.6: Surface Rule Diagram for $K_p$ .....	43
Figure 5.7: Surface Rule for $K_i$ .....	44
Figure 5.8: Surface Rule Diagram for $K_d$ .....	44
Figure 5.9: Rule Viewer for Fuzzy Controller.....	45
Figure 5.10: Simulation diagram of fuzzy controller for pitch control system.....	46
Figure 5.11: Fuzzy Controller Subsystem .....	47
Figure 5.12 Plant Subsystem.....	47
Figure 5.13: The unit step response of wind turbine with Fuzzy controller .....	48
Figure 5.14: Simulation diagram of an Adaptive fuzzy-PID controller for pitch control system .....	49
Figure 5.15: Subsystem- Fuzzy Controller .....	50
Figure 5.16: Subsystem- PID Controller .....	50
Figure 5.17: The unit step response of wind turbine with Adaptive Fuzzy PID controller .....	51
Figure 5.18: Comparison of unit step response of wind turbine pitch controllers.....	52

## **Glossary**

**DFIG-Doubly Fed Induction Generator**

**Individual Pitch Control- IPC**

**Pitch Control -PC**

**PID-Proportional Integrator Derivative**

**Fuzzy Logic Control-FLC**

**Wind Turbine Generator -WTG**

# Chapter 1- Introduction

## 1.1 Background

Energy crisis is the one of the biggest problems faced by people in the twenty-first century. The increase in the demand for electric energy along with the availability of limited fossil fuels have together contributed to the need for shifting from the human dependency on conventional resources for energy to the renewable energy resources.

There are three important renewable energy resources available to us: solar, gravitational and geothermal energy. Wind energy is one of the indirect consequence from the incident solar energy, promoting air circulation between hot and cold zones [3]. The kinetic energy present in the wind can be converted to mechanical energy by using a wind turbine and further into electrical energy by using wind turbine generator.

Suppose if 'm' is the mass of the stream of air moving with velocity 'v' then the kinetic energy of the air can be expressed as

$$E = \frac{1}{2}mv^2 \quad (1.1)$$

If A= area of the rotor blade exposed to this wind stream, then the kinetic energy of the air available to the wind turbine can be expressed as

$$E = \frac{1}{2}\rho\vartheta v^2 \quad (1.2)$$

Where  $\rho$  is the air density and  $\vartheta$  is the volume of the air parcel available to the rotor. The air parcel interacting with the rotor per unit time has a cross-sectional area equal to the rotor area (A) and thickness equal to the wind velocity (v). Hence, the energy per unit time, that is power, can be expressed as [1]

$$P = \frac{1}{2}\rho Av^3 \quad (1.3)$$

The above equation shows the power available to the wind turbine. However, when the wind passes through the turbine, only a part of this energy can be extracted, while the remaining gets carried away by the passing wind. The power coefficient  $C_p$  determines how much actual power will be produced by the rotor. The maximum power that can be extracted is calculated using the following equation.

$$P_t = \frac{1}{2} \rho A C_p v^3 \quad (1.4)$$

The power coefficient  $C_p$  depends on the tip-speed ratio (the ratio between the linear velocity of the blade tip ( $R \cdot \omega$ ) and the wind velocity ( $v$ )).

$$\text{Tip - Speed Ratio } \lambda = \frac{\omega_t \cdot R}{v} \quad (1.5)$$

Where  $R$  is the radius of the turbine. Despite the great technologic development on the wind systems, the performance of the first conversion is still far from the Betz limit, 59% [7]. The Betz limit is the theoretical maximum [efficiency](#) for a [wind turbine](#), conjectured by German physicist Albert Betz in 1919. Betz concluded that this value is most only 59% of the kinetic energy from wind can be used to spin the turbine and generate electricity [7].

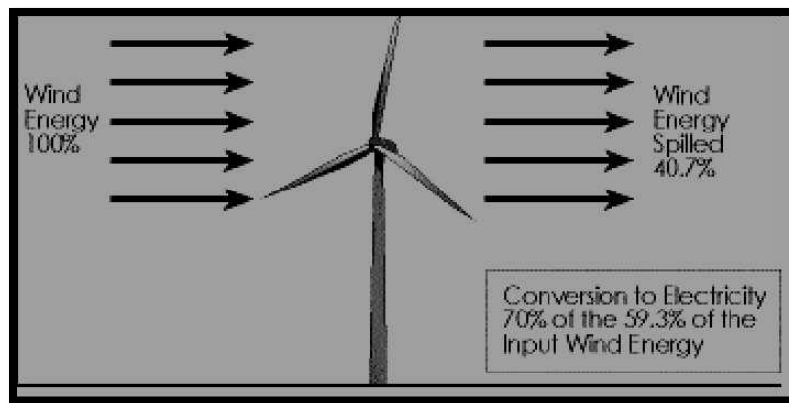

Figure 1.1: Illustrating the Principal of Betz Law [7]

## 1.2 Motivation

To increase the power capacity of the wind turbine, larger rotors are being built which causes an increase in loads such as aerodynamic, gravitational, centrifugal, gyroscopic and operational loads (explained in section 2.3). Increase in these loads on the wind turbine system causes mechanical damages which can result in the decrease in the lifespan and efficiency of the wind turbine [9]. With the help of good pitch angle controllers, the pitch of the rotor blades can be altered which results in reduction of the aerodynamics loads and other loads across the blades. This mechanism uses the fact that much of these fatigues causing loads are partly deterministic, periodic and vary slowly over a fixed time [16]. Modern wind turbine systems have built in controllers to predict the best pitch angle for the wind turbine blade under various wind speed scenarios which will serve as the pre-set pitch angle. In this thesis, the main goal is to design a controller that will drive the pitch angle of the blades of the wind turbine system to the preset pitch angle so that the aerodynamics loads and other loads on the blades are reduced. Reduction in the loads on the blades will ultimately help to improve the performance and power output daily of the wind turbine.

## 1.3 Problem Statement/Research Questions

The main objective of this work is to achieve the following objectives:

- 1) Which is the best controller- PID or Fuzzy or Fuzzy-PID for pitch control in wind turbines?
- 2) Examine the advantage and disadvantages of PID, Fuzzy, Fuzzy-PID controllers.

3) Comparison of time domain specifications of Pitch Control System for Unit Step Input Using Conventional PID, Fuzzy and Adaptive Fuzzy- PID Controllers

## 1.4 Thesis Outline

This thesis is organized as follows: chapter one gives an overview introducing the thesis, the second chapter contains the literature review, the third chapter then introduces the main construction of the wind turbine and explains the basic principles of physics on which any wind turbine works, the fourth chapter presents the concepts of the individual pitch control using the three controllers (PID, Fuzzy, Fuzzy-PID), the fifth chapter shows the Simulink model that shows tracks the output pitch angle with the desired pitch angle, the sixth chapter illustrates the simulation and results of this research and the final chapter covers the conclusion, recommendation and future work.

Chapter – 1: Gives an introduction into the basic idea on wind energy, the concept with the amount of power available, and explains the thesis research questions as well as the thesis outline.

Chapter -2: Literature Review of the Wind Turbine where detailed study about the wind turbine components and the different control techniques of wind turbine is done.

Chapter – 3: Explains the mathematical model of wind turbine

Chapter – 4: Explains the three types of controllers- PID, Fuzzy and Adaptive Fuzzy PID

Chapter – 5: Design and implementation of the three controllers on the wind turbine system model. The block diagrams for each of the implementation and its results are explained.



Chapter – 6: Simulation of the Wind Turbine system on Simulink using the three controllers and discussion as well as comparison of all the results are carried out.

Chapter – 7: Gives the conclusions and scope of future work.

## Chapter 2- Literature Review

### 2.1 Wind Turbine

Wind turbines harness the power of the wind and use it to generate electricity. In simple words, a wind turbine works the opposite of a fan. Instead of using electricity to make wind, like a fan, wind turbines use wind to make electricity [19]. The figure below illustrates the inside view of a wind turbine.

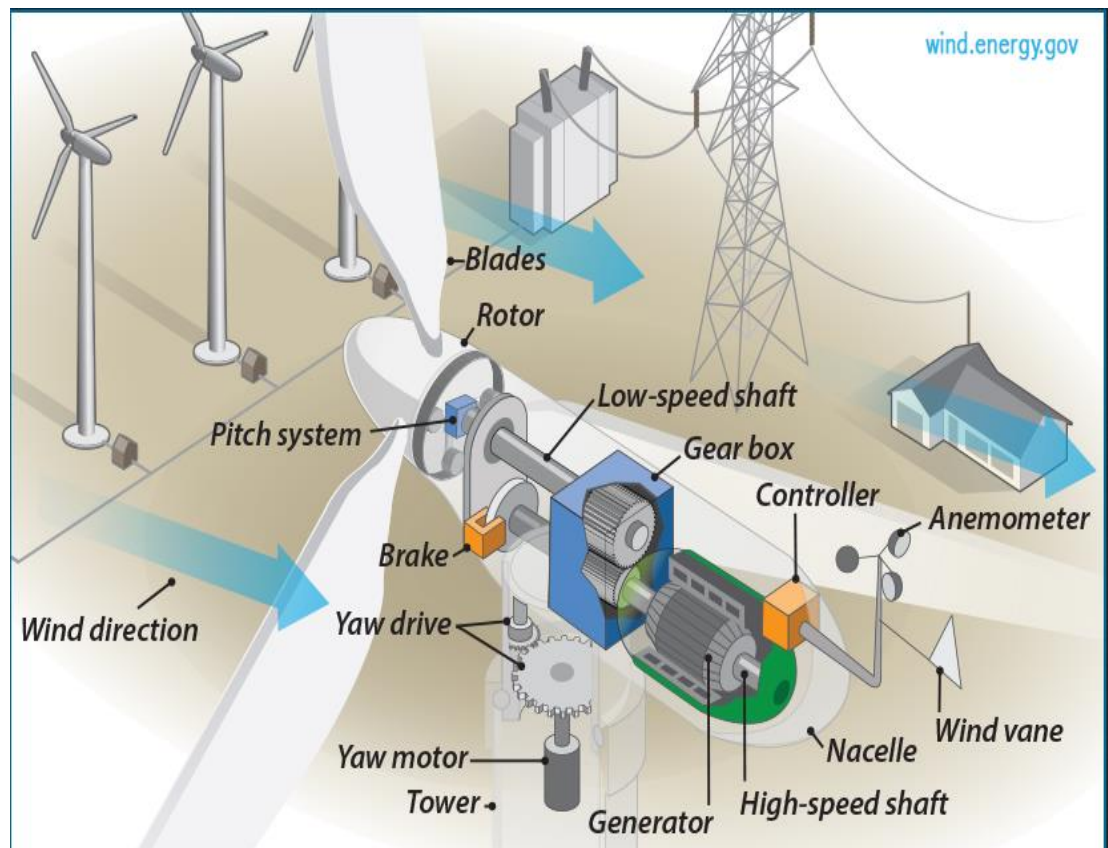

Figure 2.1: Inside of A Wind Turbine [19]

The following are the components of the wind turbine and its functions

**Anemometer:** Measures the wind speed and transmits wind speed data to the controller.

**Blades:** Rotates when wind is blown over them, causing the rotor to spin. Most turbines have either two or three blades.

**Brake:** Stops the rotor mechanically, electrically, or hydraulically, in emergencies.

**Controller:** Starts up the machine at wind speeds of about 8 to 16 miles per hour (mph) and shuts off the machine at about 55 mph. Turbines do not operate at wind speeds above about 55 mph because they may be damaged by the high winds [19].

**Gear box:** The main function is to connect the low-speed shaft to the high-speed shaft so that the speed is increased from 30-60 rotations per minute (rpm) to about 1,000-1,800 rpm; the speed which is required by generators to produce electricity [19].

**High-speed shaft:** Drives the generator.

**Low-speed shaft:** Rotates the low-speed shaft at 30-60 rpm speed.

**Nacelle:** It contains the gear box, the shafts, generator, controller, and brake [19].

**Pitch:** The main function of pitch is to adjust the blades of the wind turbine in or out of the wind speed to control the rotor speed so that rotor speed is within the allowed operational limit.

**Rotor:** Blades and hub together form the rotor.

**Wind vane:** Measures wind direction and communicates with the yaw drive to orient the turbine properly with respect to the wind.

**Yaw drive:** Orients upwind turbines to keep them facing the wind when the direction changes. Downwind turbines don't require a yaw drive because the wind manually blows the rotor away from it.

**Yaw motor:** Powers the yaw drive.

## 2.2 Types of Wind Turbine

There are two types of wind turbine generators: fixed speed and variable speed WTG.

### 2.2.1. Fixed Speed WTGs

In the Fixed Speed WTGs squirrel-cage induction generators are used. The rotor of the turbine blades is coupled to the rotor of the generator through a gearbox while the stator winding of the generator is directly connected to the grid [17]. So, the turbine could utilize the kinetic energy stored in the turbine blades and contributes to the system frequency stability by providing spinning inertia [23]. There is a strong coupling between the squirrel-cage induction generator stator and power system and low nominal slip as a result of which, any small deviation in any of them can cause deviation in the system speed which in turn leads to a change in rotational speed. The major drawback is that these type of WGT cannot track wind speed fluctuations. Also, the energy capture is not as efficient as in variable speed systems.

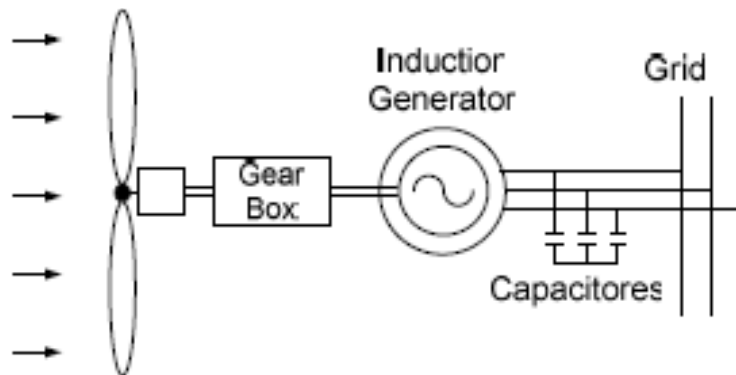

Figure 2.2: Fixed speed wind turbine generator [23]

### 2.1.2 Variable Speed WTGs

In case of Variable speed WTGs, they are equipped either with synchronous generators or doubly-fed induction generators (DFIG) having asynchronous generators. In synchronous generators, the wind turbine spin at whatever speed such that maximum power is achieved. Due to this, the electrical output frequency would vary due to instantaneous variation in the wind velocity. Hence these generators are decoupled from

the grid by using a back-to-back ac/dc/ac converter attached to the stator of the synchronous generator [13].

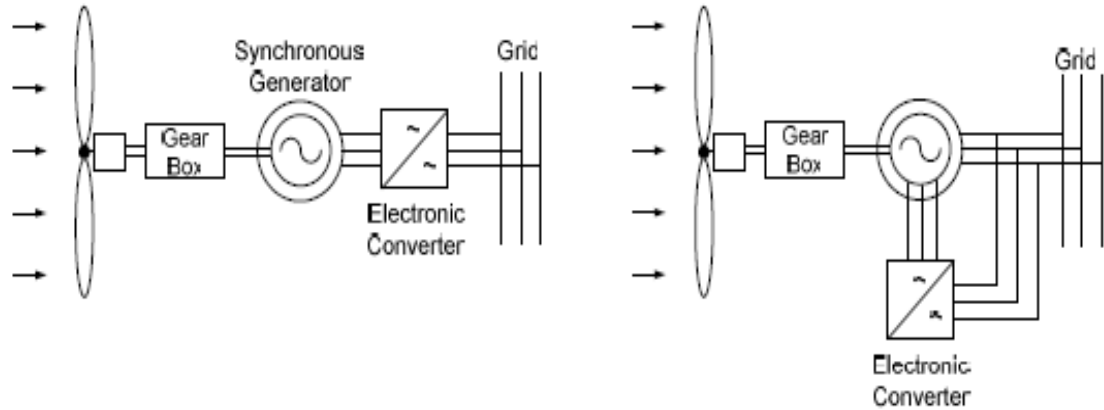

Figure 2.3: Variable speed wind turbine generators; (a) with synchronous generator, (b) with DFIG (asynchronous generator) [13]

First, the variable frequency ac output of generator is rectified into dc using high power switching transistors; then, the dc converts back to ac at grid frequency through an inverter before feeding to the grid [3]. In this type of generators, the wind turbine generator has no inertial response during a frequency change as the stator is isolated from the system and hence the power output does not change with the frequency fluctuations.

In the DFIG, as shown in fig 2.b, the stator winding is directly connected to the grid whereas the rotor winding is connected to the power system by employing a back-to-back ac/dc/ac converter which varies the electrical frequency as acceptable by the grid [6]. This type of construction results in the difference between the electrical frequency and the mechanical frequency. In these type of converters, the active and reactive power can be controlled using constant power factor or constant voltage [3]. The inertial response provided by the DFIG during a frequency deviation, depends on the control structure used in the converter and their parameters.

Some of the advantages of the Variable speed WTGs are the following: higher energy capturing, lower mechanical stress, more constant output power, and reduced noise compared with fixed speed machines [5].

### 2.3 Loads on the Wind Turbine System

The wind turbine system experiences the following loads/forces under various wind speed scenarios such as the aerodynamic load, gravitational load, centrifugal load, gyroscopic load and operational load.

The Aerodynamic load is generated by lift and drag forces on the blades on the wind turbine and it dependent on wind velocity, blade velocity, surface finish, angle of attack (which is determined by the blade pitch) and yaw angle. The aerodynamic lift and drag forces result in producing a thrust in the direction of rotation absorbed by the generator and reaction forces. The reaction forces are substantial acting in the flatwise bending plane, and must be tolerated by the blade with limited deformation [4].

Gravitational forces are mass dependant and is defined simply as mass multiplied by the gravitational constant whereas the centrifugal force is a product of rotational velocity squared and mass. Fatigue loads can occur when a material is subjected to a repeated non-continuous load which causes the fatigue limit of the material to be exceeded.

Fatigue loading is a result of gravitational cyclic loads which are equal to the number of rotations throughout the lifetime of the turbine, typically 20 years [19].

### 2.4 Control Techniques of Wind Turbine System

The wind energy captured by the turbine can be increased by the following two control strategies: pitch control and stall control. The initial step in both strategies is to

check the turbine's power output several times per second using an electronic controller. In case wind speed is above the operational limit, a signal is sent to the blade pitch mechanism because of which the rotor blades turn slightly out of the wind, adapting the attack angle. Once the wind drops, these blades are turned back into the wind. Turbines with this type of control mechanism is known as pitch controlled wind turbines.

In some literatures [1,3,18], combinations of P, I and D are used to adjust the turbine rotor speed for extracting maximum power without estimating the wind speed. In the stall control technique, the rotor blades are fixed onto the hub at a fixed angle. But the geometry of the rotor blade is aerodynamically designed in such a way that it ensures that from the moment the wind speed becomes too high, it causes turbulence on back rotor blades which leads to the blade stall [3]. In [6] a fuzzy based control is used to control the WT, where optimal gains are achieved by particle swarm optimization and fuzzy logic theory, without estimating the wind speed. In [11,13] again fuzzy logic control methods are used to enhance the pitch control of wind turbines connected to grids. Feedforward Learning Control for Individual Blade Pitch Control of Modern Two-Bladed Wind Turbines is explained in [16]. In [17], another approach to the control of large wind turbines by multivariable design is investigated by the author. This multivariable design method is used because it helps in controlling the output power simultaneously operating at variable speed to control tip speed ratio and so the power extraction for different wind speeds [17].

Authors in [22] discussed a combination fuzzy and PID controller for controlling the WT at above rated wind speed. This paper, however uses a PID control, fuzzy control as well an Adaptive fuzzy-PID for pitch control of wind turbine system.

## Chapter 3 -Mathematical Model of Wind Turbine

### 3.1 Physics of Wind Turbine

The equations (1) – (5) in Chapter 1, describes how the wind speed affects the wind power generation. Consider a disk of area ‘A’ with an air mass ‘m’ flowing through that area with speed ‘v’. In a time ‘dt’ the mass will move a distance ‘vdt’, creating a cylinder of volume ‘Avdt’ which has mass ‘dm= A ρ vdt’, where ‘ρ’ is the air density is the air. The power contained in the moving mass is the time rate of change in kinetic energy, given by

$$P = \frac{d(KE)}{dt} = d\left(\frac{1}{2}mv^2\right) = \frac{1}{2} \frac{d(mv^2)}{dt} = \frac{1}{2} \frac{v^2 d(m)}{dt} = \frac{1}{2} A\rho v^3 \quad (3.1)$$

Therefore, the power of the wind (energy transferred to rotor) depends on the density of the air, the rotor area and is proportional to the wind speed cubed.

### 3.2 Power Curve Characteristics

The power curve of a wind turbine shows the relationship between the electrical power output of the wind turbine and the wind speeds as shown in the figure below.



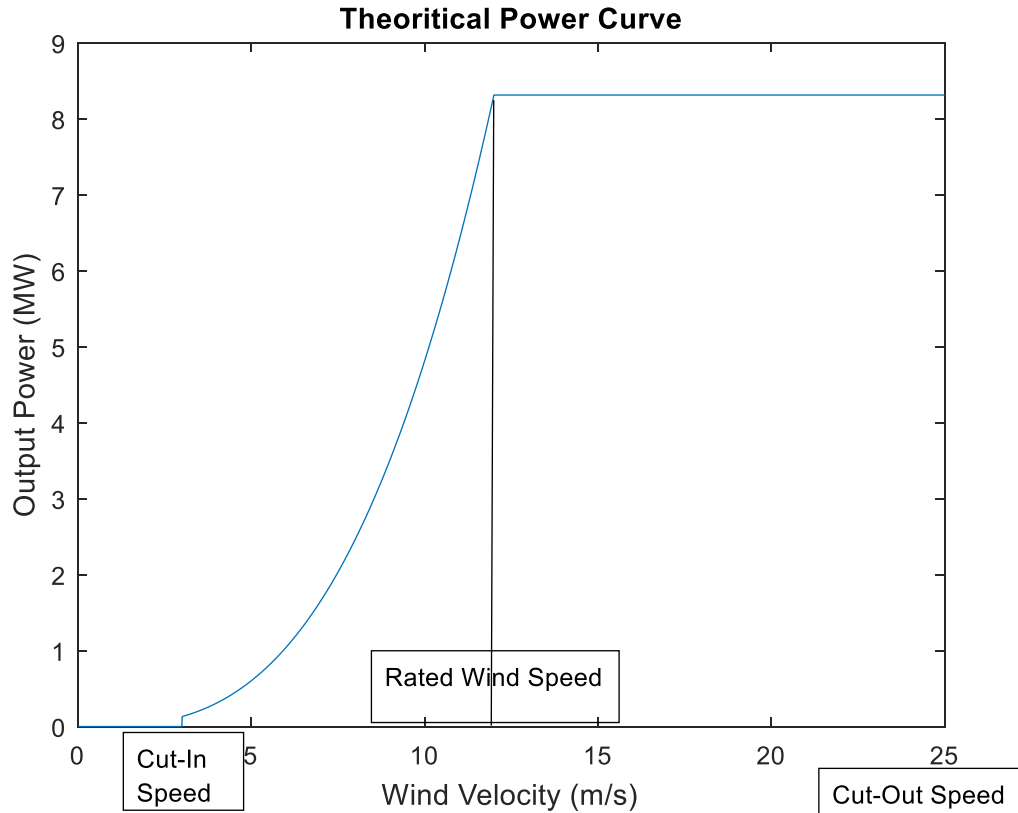

Figure 3.1: Power Curve Characteristics of a Wind Turbine

The wind turbines have a ‘cut -in’ speed, around 3-5 m/s. This is the speed at which wind turbines are designed to start running. Below this speed of wind, the energy in wind is not sufficient to overcome the inertia of the rotor; hence, the machine does not produce any power below this speed of wind. Likewise, at high wind speeds above, say, 25 m/s, the wind turbine will be programmed to stop to avoid damaging the turbine or its surroundings. The stop wind speed is called the ‘cut-out’ wind speed. The “rated wind speed” is the wind speed at which the “rated power” is achieved. This value for megawatt size turbines is about 12– 15 m/s, and it corresponds to the point at which the conversion efficiency is near its maximum [20]. The power output above the rated wind speed is

mechanically or electrically maintained at a constant level, because the high output would destroy the equipment.

As seen in the power characteristics graph, the output power of wind turbine drops sharply at lower wind speeds. This is due to the cubic power law which is proved in equation (3.1), which also states that the power available in the wind increases eight times for every doubling of wind speed and decreases eight times for every halving of the wind speed [20].

Even though the power curve helps us to determine an approximate value of power output for each wind speed, it is better to use the Weibull distribution for estimating the power output regarding the power curve. The statistical distribution of wind speed varies from place to place around the globe, depending upon local climate conditions, the landscape, and its roughness [20].

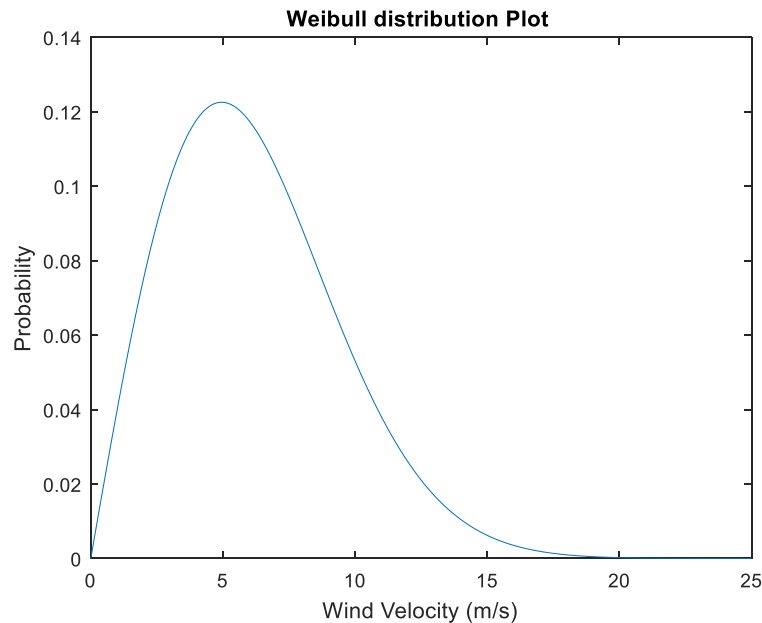

Figure 3.2: Weibull distribution plot between wind velocity and probability for a site which has a mean wind speed of 7 m/s

### 3.3 Relationship between Power Coefficient $C_p$ and the Tip Speed Ratio $\lambda$

In a Wind Turbine, Betz' Law (maximum 59%) rules the mechanical to electrical energy conversion.

$$\text{Power Coefficient of the Turbine } C_p = \frac{P_R}{P} \quad (3.2)$$

where  $P_R$  =mechanical power of rotor blades and P =power of the wind

$$P_R = \frac{1}{2} C_p A \rho v^3 \quad (3.3)$$

The dependence of  $C_p$  on the tip speed ratio  $\lambda$  and the pitch angle  $\varphi$  can be approximated as in equation below [20].

$$C_p(\lambda, \varphi) = c_1 \left[ c_2 \frac{1}{\beta} - c_3 \varphi - c_4 \varphi^x - c_5 \right] \exp\left(-c_6 \frac{1}{\beta}\right) \quad (3.4)$$

where the coefficients  $c1-c6$  and  $x$  have variant values for different wind turbines and  $\beta$  is a parameter defined as

$$\beta = \frac{1}{\left(1/(\lambda + 0.08\varphi) - 0.035/(1 + \varphi^3)\right)} \quad (3.5)$$

where  $\lambda = \omega R/v$ ,  $R$  is the blade length and  $\omega$  is the blade angular velocity.

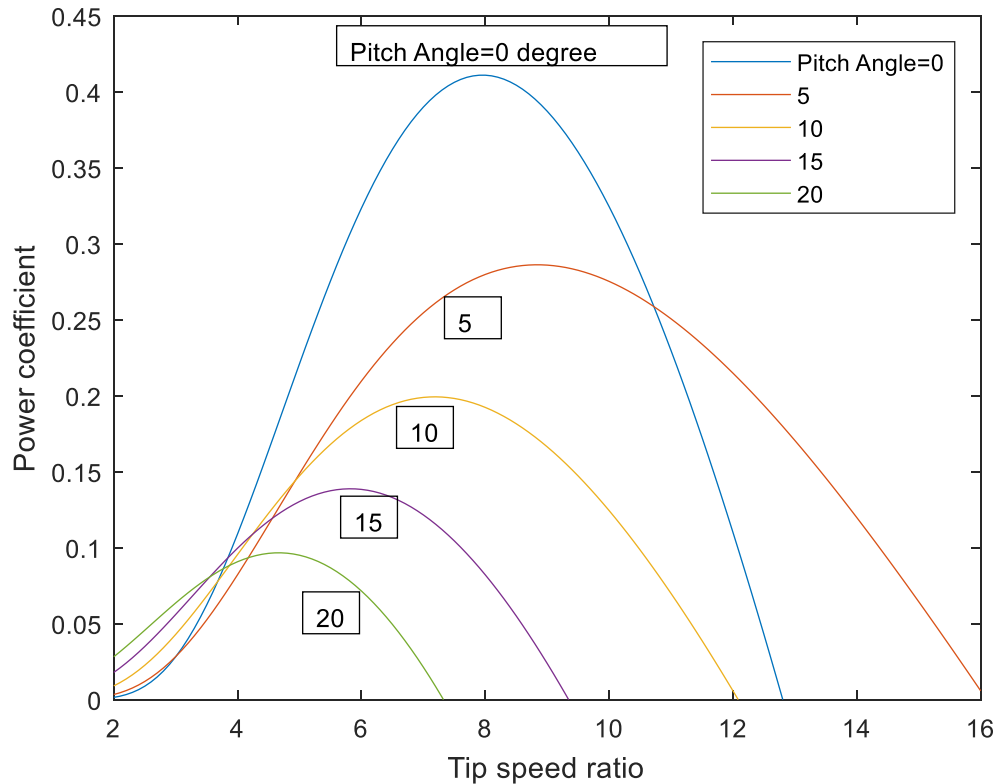

Figure 3.3 : The relationship between the  $C_p$  and  $\lambda$

The above figure is the plot for Equation (3.5) for different values of the pitch angle  $\varphi = 0^\circ, 5^\circ, 10^\circ, 15^\circ, 20^\circ$ . The coefficient values used are:  $c1 = 0.5, c2 = 116, c3 = 0.4, c4 = 0, c5 = 5, c6 = 21$  [2]. It is clear from the graph that for different values of pitch angle, the  $C_p, \lambda$  relationship varies and the maximum  $C_p$  is when pitch angle is zero.

### 3.5 Pitch Angle Control

Blade pitch refers to turning the angle of attack of the blades of a wind turbine rotor into or out of the wind to control the production or absorption of power [21]. Blade pitch control is a feature of nearly all large modern horizontal-axis wind turbines. The key function of the blade pitch control system is to keep the rotor speed within the operation limits by controlling the pitch angle which changes according to wind speed.

The equation below shows how the rotor power (mechanical power) depends on the wind velocity 'v' and the pitch angle 'φ'.

$$P_R = C_p(\lambda(v), \varphi) P = C_p(\lambda(v), \varphi) \frac{1}{2} A \rho v^3 = P_R(v, \varphi) \quad (3.6)$$

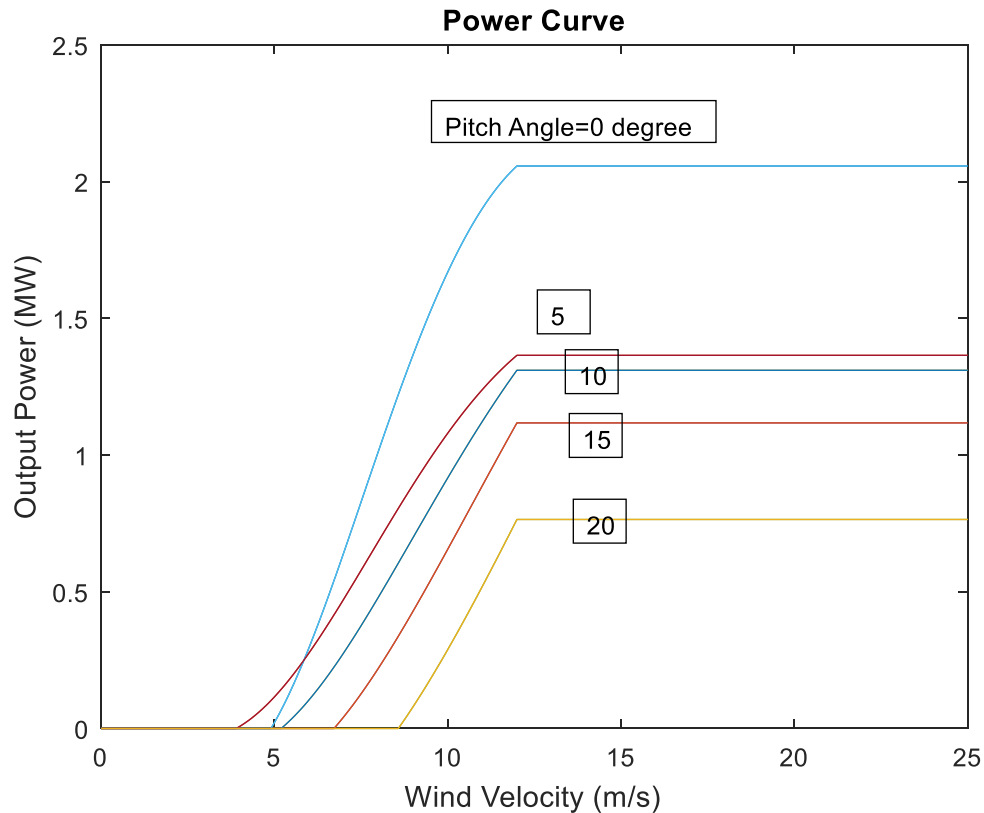

Figure 3.4: Effect of the pitch angle on the output power

The above plot shows how the output power varies with the incoming wind velocity. It is observed that the maximum output is when the pitch angle is zero and thereafter as the pitch angle changes, the value of the output power also varies. Hence it is required to control the pitch angle for the optimal performance of the wind turbine.

### 3.6 Modelling of the Wind Turbine System

The block diagram of a typical wind turbine system model is shown in the figure below [12]. In the following sections, the pitch actuator model and the drive terrain model are explained.

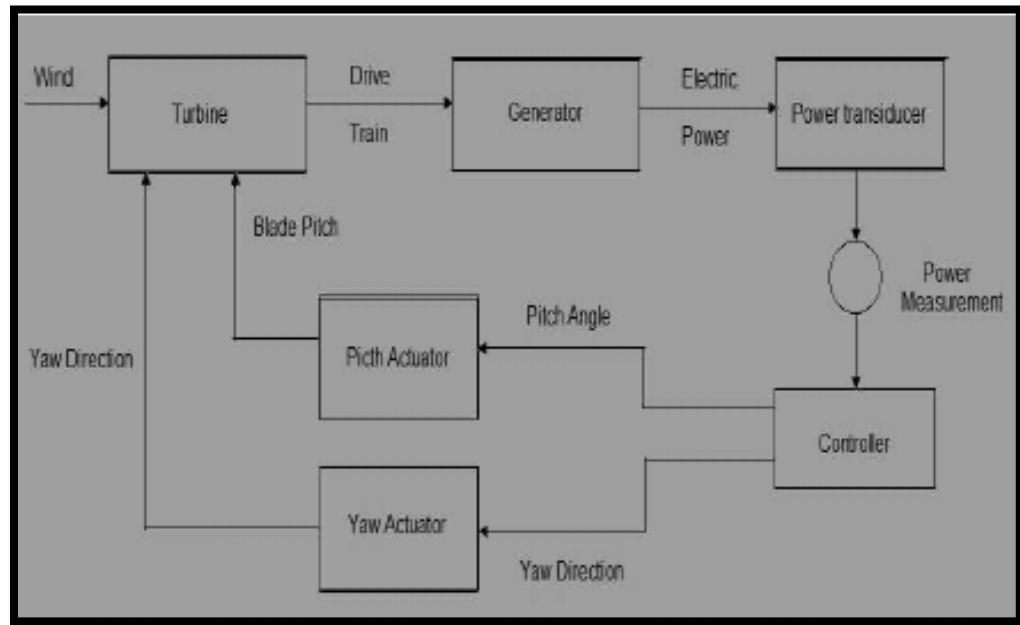

Figure 3.5: Wind Turbine System Feedback Control System Model

#### 3.6.1 Pitch Actuator Model

The pitch actuator is used to turn blades along their longitudinal axis. The actuator model describes a dynamic behavior between a pitch demand,  $\beta_d$  from the pitch controller and measurement of pitch angle [12]

The change in pitch angle is given by

$$d\beta / dt = (\beta_d - \beta) / T_\beta \quad (3.7)$$

$$T_\beta \cdot d\beta / dt = (\beta_d - \beta) \quad (3.8)$$

$$T_{\beta} \cdot d\beta / dt + \beta = \beta_d \quad (3.9)$$

Applying Laplace transforms, we get

$$T_{\beta} \cdot \beta_s + \beta = \beta_d \quad (3.10)$$

$$\beta_s (T_{\beta} \cdot s + 1) = \beta_d \quad (3.11)$$

$$\beta / \beta_d = 1 / (s \cdot T_{\beta} + 1) \quad (3.12)$$

This is the required Transfer Function. The value of time constant of pitch actuator,  $T_p$  can be calculated from initial parameters of Wind Turbine [12] shown in Table I.

Table 1: Parameters of Wind Turbine

Rated generator power , $P_e$	1000 KW
Rated generator speed, $W_g$	1500 rpm
Rated turning speed of rotor, $W_t$	20 rpm
Wind turbine blade radius, $R$	35 m
Reference pitch angle, $\beta_d$	0 to 90 deg
Rate of change of pitch angle	0.6 deg / sec
Control accuracy of pitch angle	0.3 deg
Damping coefficient, $B$	2 N.m / rad / sec
Drive-train inertia , $J_t$	0.75 N.m <sup>2</sup>

$$T_{\beta} = (\beta_d - \beta) / \left( \frac{d\beta}{dt} \right) = 0.3 / 0.6 = 0.5$$

$$\beta / \beta_d = 1 / (0.5s + 1) \quad (3.13)$$

### 3.6.1 Drive Terrain Model

The figure below shows the drive terrain model.

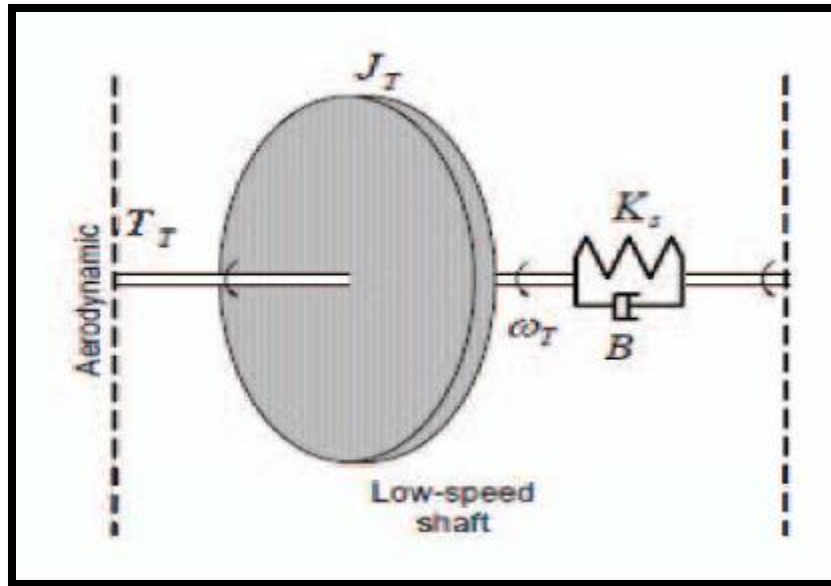

Figure 3.6: Mechanical model of drive train

The parameters taken while modeling the drive train are shown in Table 2.

Table 2: Mechanical Model Parameters of Drive Train

Parameter	Description	Parameter	Description
$J_T$	Wind turbine inertia [kg.m <sup>2</sup> ]	$w_T$	Wind turbine shaft speed [rad/s]
$J_G$	Generator inertia [kg.m <sup>2</sup> ]	$w_g$	Generator shaft speed [rad/s]
$K_s$	Stiffness coefficient [N.m/rad]	$\theta_T$	Wind turbine shaft angle [rad]
$B$	Damper coefficient [N.m/rad/sec]	$\theta_g$	Generator shaft angle [rad]
$T_T$	Wind turbine torque [N.m]	$1:n_{gear}$	Gear ratio
$T_G$	Generator electro-mechanical torque [N.m]		



The dynamics of drive-train are described by following differential equations:

$$J_T \cdot d/dt(w_T) = T_T - (K_S \delta\theta_T + B \delta w) \quad (3.14)$$

$$d/dt(\delta\theta) = \delta w \quad (3.15)$$

Then by using Newton's second law of motion, we get

$$Jdw/dt = T - Bw \quad (3.16)$$

Applying Laplace transform on both sides

$$J \cdot Ws = T - BW \quad (3.17)$$

$$J \cdot Ws + BW = T$$

$$W(Js + B) = T$$

$$W/T = 1/(Js + B) \quad (3.18)$$

This is the required first order Transfer function of Drivetrain. This can also be represented as

$$W/T = (1/B)/((J/B) \cdot s + 1) \quad (3.19)$$

$$W/T = (1/2)/((0.75/2) \cdot s + 1) = 0.5/(0.375s + 1) \quad (3.20)$$

Thus, the mathematical model of wind turbine is derived.

## Chapter 4- Pitch Angle Controllers for Wind Turbine

Pitch angle control method is a basic approach to improve the performance of the power generation system including different types of wind turbines [4]. Although a wind turbine can be built in either a vertical-axis or horizontal-axis configuration, we focus on horizontal-axis wind turbines (HAWTs) because they dominate the utility-scale wind turbine market. The purpose of the pitch angle control might be expressed as follows [4]:

- Optimizing the wind turbine power output. Below rated wind speed, the pitch setting should be at its optimum value to give maximum power.
- Preventing the mechanical power input to beat the design limits. Above rated wind speed, pitch angle control provides an effective method of regulating the aerodynamic power and loads produced by the rotor.
- Minimizing fatigue loads of the turbine mechanical component. Action of the control system can have a major impact on the loads experienced by the turbine. The design of the controller must consider the effect of loads, and the controller should ensure that excessive loads will not result from the control action. It is possible to go further than this, and explicitly design the controller with the reduction of certain fatigue loads as an additional objective.

## 4.1 PID Controller

The conventional PID controller is a linear controller, which takes the proportion (P), integration (I) and differential (D) of the deviation as the input variables for the control function that will produce the output acting on the controlled target (T). The principles are shown as Fig.4.1 [18].

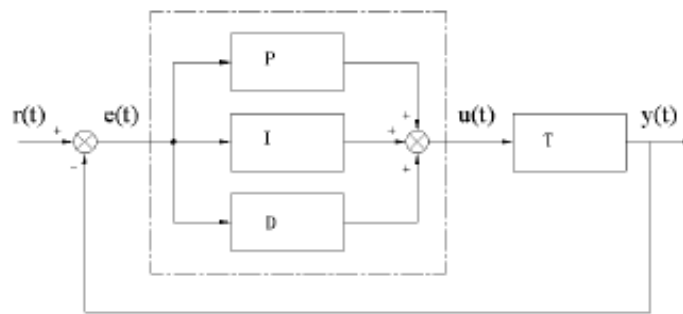

Figure 4.1: Principle Diagram of PID Controller

The output of a PID controller, equal to the control input to the plant, in the time-domain is as follows:

$$u(t) = K_p e(t) + K_i \int e(t) dt + K_d \frac{de}{dt} \quad (4.1)$$

Let's look at how the PID controller works in a closed-loop system using the schematic shown below [22].

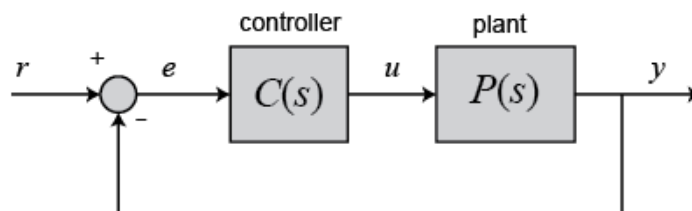

Figure 4.2: Unity Feedback System

The variable ( $e$ ) represents the tracking error, the deviation between the desired input value ( $r$ ) and the actual output ( $y$ ) from the controlled target. This error signal ( $e$ ) will be sent to the PID controller, and the controller computes both the derivative and the integral of this error signal. The control signal ( $u$ ) to the plant is equal to the proportional gain ( $K_p$ ) times the magnitude of the error plus the integral gain ( $K_i$ ) times the integral of the error plus the derivative gain ( $K_d$ ) times the derivative of the error [4]. This control signal ( $u$ ) is sent to the plant, and the new output ( $y$ ) is obtained. The new output ( $y$ ) is then fed back and compared to the reference to find the new error signal ( $e$ ). The controller takes this new error signal and computes its derivative and its integral again, ad infinitum [4]. The transfer function of a PID controller is found by taking the Laplace transform of

$$K_p + \frac{K_i}{s} + K_d s = \frac{K_d s^2 + K_p s + K_i}{s} \quad (4.2)$$

$K_p$ = Proportional gain;  $K_i$  = Integral gain;  $K_d$ = Derivative gain

A proportional controller ( $K_p$ ) will have the effect of reducing the rise time and will reduce but never eliminate the steady-state error [4]. An integral control ( $K_i$ ) will have the effect of eliminating the steady-state error for a constant or step input, but it may make the transient response slower and create oscillations. A derivative control ( $K_d$ ) will have the effect of increasing the stability of the system, reducing the overshoot, and improving the transient response.

## 4.2 Tuning of the PID Parameters

This section describes one of the several methods for tuning of controller parameters in PID controllers, that is, methods for finding proper values of  $K_p$ ,  $K_i$  and  $K_d$ . The main aim of tuning the parameter is to achieve faster response and good stability (low oscillations) of the plant system

The following are the steps for tuning [18]:

1. First, ensure that all the controller gains ( $K_p, K_i, K_d$ ) are set to zero. Increase  $K_p$  until the control loop gets satisfactory stability as seen in the response in the measurement signal after e.g. a step in the setpoint or in the disturbance (exciting with a step in the disturbance may be impossible on a real system, but it is possible in a simulator). If you do not want to start with  $K_p = 0$ , you can try  $K_p = 1$  (which is a good initial guess in many cases) and then increase or decrease the  $K_p$  value until you observe a slight overshoot but a well damped response.
2. Set the integral time  $T_i$  equal to  $T_i = 1.5T_{ou}$ , where  $T_{ou}$  is the time between the first overshoot and the first undershoot of the step response (a step in the setpoint) with the P controller, see Figure 4.3

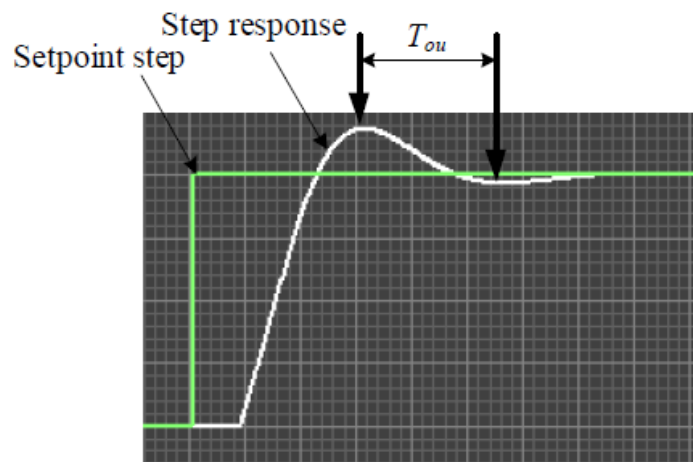

Figure 4.3. Reading off the time between the first overshoot and the first undershoot of the step response with P controller

3. Check the stability of the control system by applying a setpoint or unit step. Because of the introduction of the I-term, the loop with the PI controller in action will probably have somewhat reduced stability than with the P controller only. If you think that the stability has become too poor, try reducing  $K_p$  somewhat, e.g. reduce it to 80% of the original value.
4. If you want to reduce the overshoot, and improving the transient response and reduce overshoot, you need to include the D-term. You can try setting  $T_d$  as follows:  $T_d = T_i/4$ . Now, the controller becomes a PID controller.

### 4.3 Overview of Fuzzy Control

Fuzzy control theory is an automatic control theory based on fuzzy set theory, the form of fuzzy language knowledge representing and reasoning, and fuzzy logic rules to simulate the way of thinking and reasoning of human beings. There are several characters of fuzzy control as follows: we can express the related knowledge and experience of manipulators or experts as linguistic variables based on the fuzzy control rules, and then use these rules to control the unknown models or models that are difficult to be established accurately in mathematics of forces [11].

The fuzzy logic controller design involves fuzzification, rule base, inference and defuzzification. To design this controller MATLAB/Simulink is used.

#### 4.3.1. Fuzzification

In this step, the inputs and outputs are defined for the fuzzy controller. We have defined two inputs (error and change in error) and three outputs ( $K_p$ ,  $K_i$ ,  $K_d$ ) for this application. Based on the error ( $e$ ) and change in error ( $ec$ ), the three parameters of PID controller are automatically adjusted [11]. We have selected Gaussian membership

functions for both inputs and outputs. The variable universe of discourse for the system pitch error  $e$  and the change in error  $'ec'$  is taken as  $\{-5, -4, -3, -2, -1, 0, 1, 2, 3, 4, 5\}$ , then divided it into seven levels, the linguistic values of the 7 fuzzy sets were taken as  $\{NB, NM, NS, ZO, PS, PM, PB\}$ , that is  $\{ \text{Negative Big, Negative Medium, Negative Small, Zero, Positive Small, Positive Medium, Positive Big} \}$ [11]. The input error  $'e'$  and output  $'Kp'$  with gaussian membership functions are shown in Fig. 4.4 and Fig. 4.5

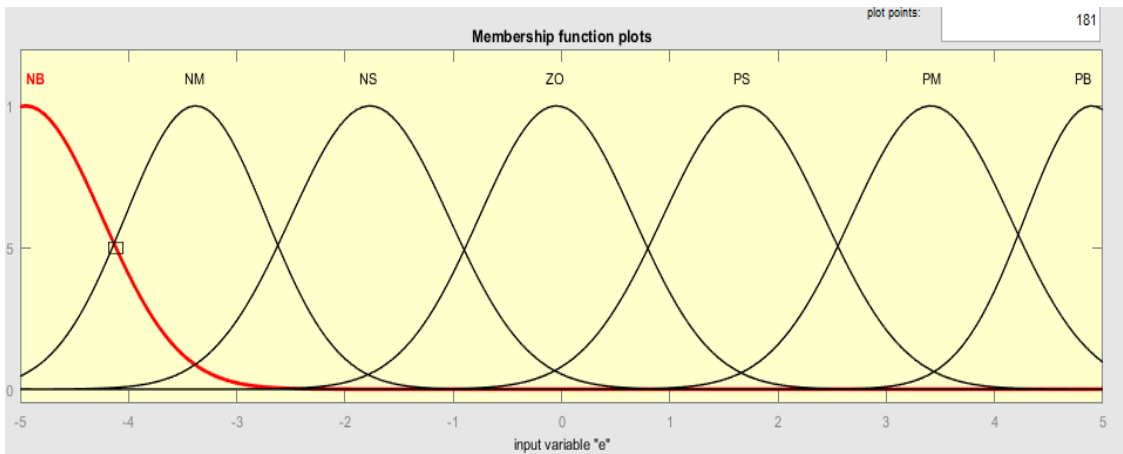

Figure 4.4: Membership Function Plots for Inputs 'e' and 'ec'

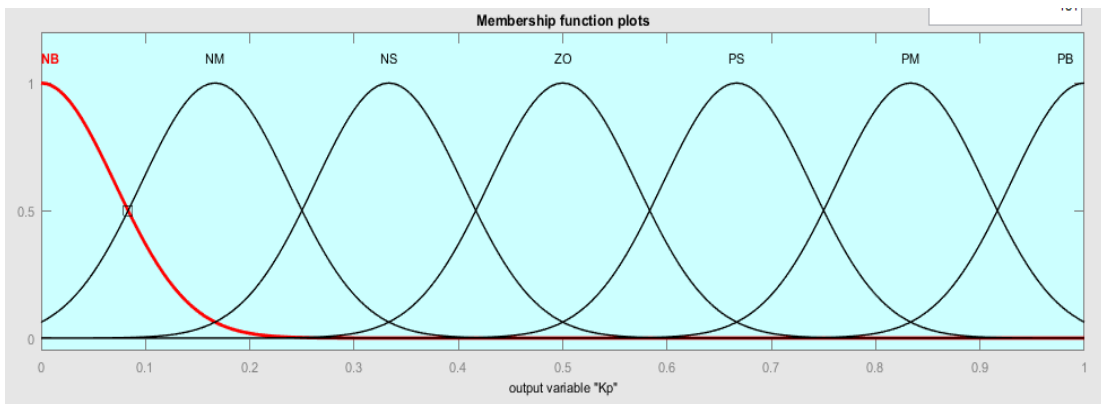

Figure 4.5: Membership Function Plots for Outputs

### 4.3.2 Fuzzy Rule Base

According to the input and output membership functions 49 fuzzy rules for each parameter have been carried out and shown in tables below.

Table 3: Fuzzy Rules for Kp

<b>e</b>	<b>ec</b>						
	<b>NB</b>	<b>NM</b>	<b>NS</b>	<b>ZO</b>	<b>PS</b>	<b>PM</b>	<b>PB</b>
<b>NB</b>	PB	PB	PM	PM	PS	ZO	ZO
<b>NM</b>	PB	PB	PM	PS	PS	ZO	NS
<b>NS</b>	PM	PM	PM	PS	ZO	NS	NS
<b>ZO</b>	PM	PM	PS	ZO	NS	NM	NM
<b>PS</b>	PS	PS	ZO	NS	NS	NM	NM
<b>PM</b>	PS	ZO	NS	NM	NM	NM	NB
<b>PB</b>	ZO	ZO	NM	NM	NM	NB	NB

Table 4: Fuzzy Rules for Ki

<b>e</b>	<b>Ec</b>						
	<b>NB</b>	<b>NM</b>	<b>NS</b>	<b>ZO</b>	<b>PS</b>	<b>PM</b>	<b>PB</b>
<b>NB</b>	NB	NB	NM	NM	NS	ZO	ZO
<b>NM</b>	NB	NB	NM	NS	NS	ZO	ZO
<b>NS</b>	NB	NM	NS	NS	ZO	PS	PS
<b>ZO</b>	NM	NM	NS	ZO	PS	PM	PM
<b>PS</b>	NM	NS	ZO	PS	PS	PM	PB
<b>PM</b>	ZO	ZO	PS	PS	PM	PB	PB
<b>PB</b>	ZO	ZO	PS	PM	PM	PB	PB



Table 5: Fuzzy Rules for Kd

<b>e</b>	<b>Ec</b>						
	<b>NB</b>	<b>NM</b>	<b>NS</b>	<b>ZO</b>	<b>PS</b>	<b>PM</b>	<b>PB</b>
<b>NB</b>	PS	NS	NB	NB	NB	NM	PS
<b>NM</b>	PS	NS	NB	NM	NM	NS	ZO
<b>NS</b>	ZO	NS	NM	NS	NS	NS	ZO
<b>ZO</b>	ZO	NS	NS	NS	NS	NS	ZO
<b>PS</b>	ZO	ZO	ZO	ZO	ZO	ZO	ZO
<b>PM</b>	PB	NS	PS	PS	PS	PS	PB
<b>PB</b>	PB	PM	PM	PS	PS	PS	PB

The objective of the fuzzy controller will depend only on the rule base and this is composed of IF Clause and THEN- clause [11]. Enhanced response of the pitch control system is possible with effective rule base. The accuracy of output depends on the formation of rules. The rules are framed based on the frequent checking of the output response.

#### 4.3.3 Defuzzification

The process of conversion of fuzzy set in to a real number is called defuzzification. Several methods have been developed to generate real values as outputs. For this application, we employed centroid defuzzification [11].

#### 4.3 Fuzzy Adaptive PID Controller

In fuzzy logic control, the parameters are fixed. So, it is not suitable to be used where the operating conditions change in a wide range. To cope with the changes in operating conditions and to ensure optimum control performance, adaptive FLC is required [11].

Here the three parameters of PID control Kp, Ki, Kd are modified by the FLC depending on the values of pitch error e and change in pitch error 'ec'. The three parameters of PID

controller are to be adjusted based on current pitch deviation and change in pitch deviation as shown below.

$$K_p = K_p(\text{pid}) + \{ K_{pf}(\text{fuzzy}) * K_p(\text{pid}) \}$$

$$K_i = K_i(\text{pid}) + \{ K_{if}(\text{fuzzy}) * K_i(\text{pid}) \}$$

$$K_d = K_d(\text{pid}) + \{ K_{df}(\text{fuzzy}) * K_d(\text{pid}) \} \quad (4.3)$$

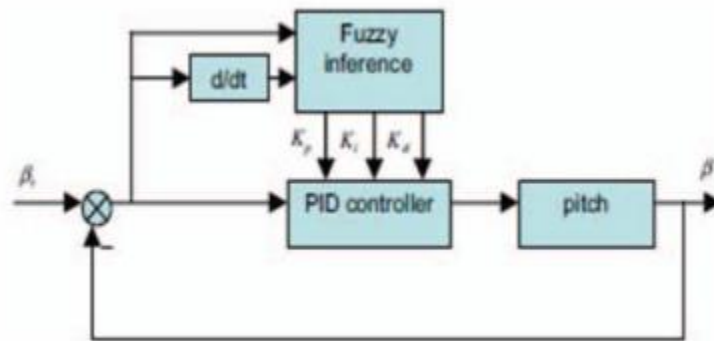

Figure 4.6: Fuzzy Adaptive PID Control Block of Pitch System

## Chapter 5- Simulation of the Controllers and Results

In this chapter, we will design three controllers to control the pitch angle of the wind turbine as well as implement the controllers in Simulink to study their effect and examine the results.

### 5.1 Simulation of the Plant without Controllers

First, we simulate the wind turbine system without any controllers to get the output. The figure below shows the Simulink model of wind turbine without any controllers.

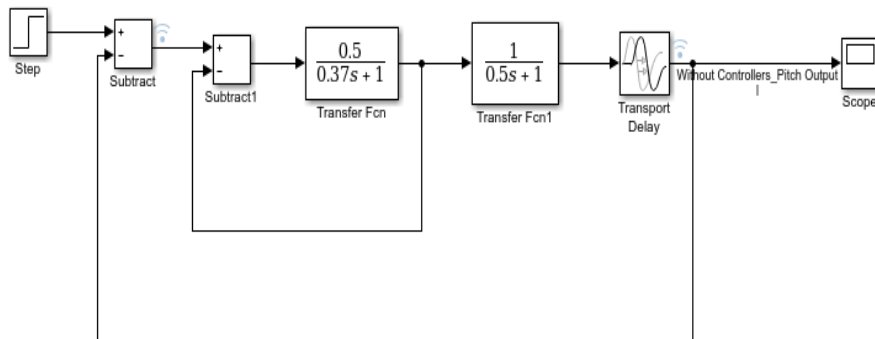

Figure 5.1: Simulink Wind Turbine Model without Controllers

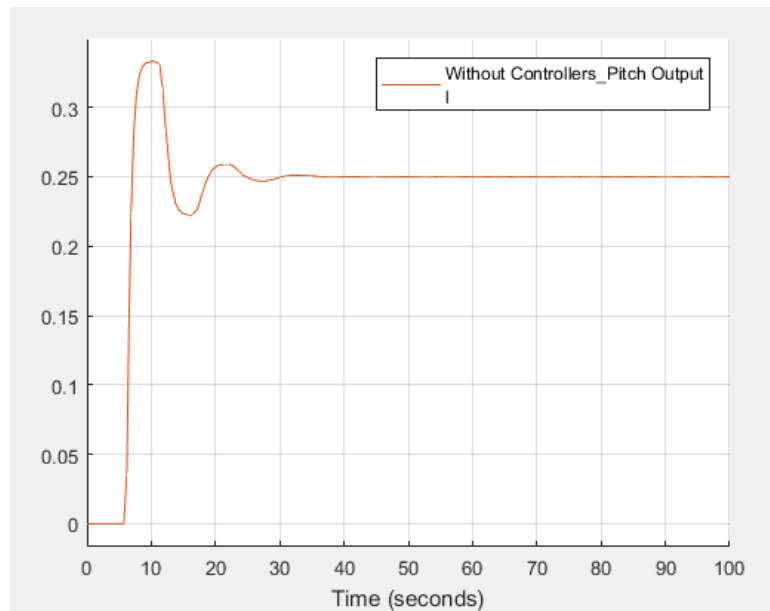

Figure 5.2: The unit step response of wind turbine without controllers

Table 6: Time Domain Specification for Unit step Input without Controller

<b>Time Domain</b>	<b>Without Controller</b>
<b>Delay Time(s)</b>	<b>8</b>
<b>Rise Time(s)</b>	<b>0.813</b>
<b>Settling Time(s)</b>	<b>38</b>
<b>Peak Overshoot (%)</b>	<b>32.157</b>
<b>Steady State Error</b>	<b>0.75</b>

The unit step response of wind turbine pitch control system without controller is shown in fig 5.2. We don't get the desired output because the input is a unit step where the steady state value is not 1. Also the overshoot is 32% and undershoot is very high which results in instability of the system. The time domain specifications observed from the response graph are tabulated in Table 6.

## 5.2 Implementation of Conventional PID Controller

The Simulink model of wind turbine pitch control system with conventional PID Controller is shown in Fig. 5.3 and the control parameters for the PID controller are shown in Fig.5.4. The model is simulated and the results are obtained, which is shown in the next section

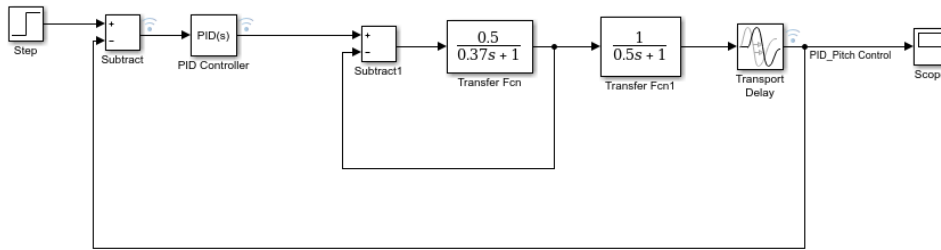

Figure 5.3: Simulation diagram of conventional PID controller for pitch control

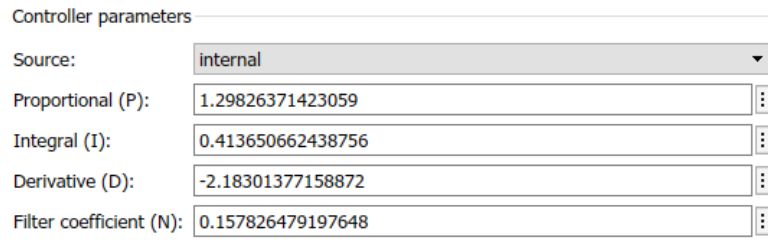

Figure 5.4 : PID Controller Parameters

### 5.3 Simulation of the Plant with PID Controller

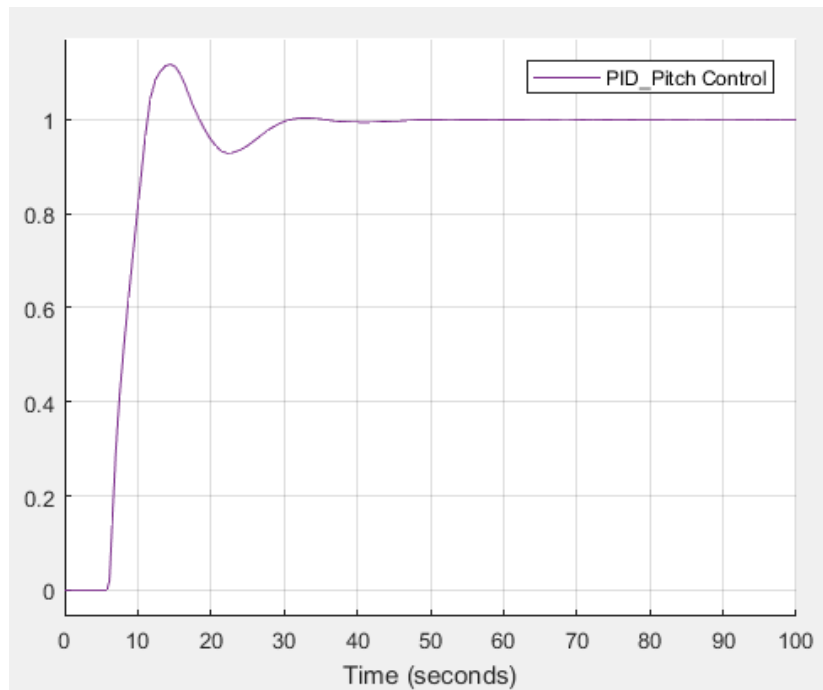

Figure 5.5: The unit step response of wind turbine with PID controller

Table 7: Time Domain Specification for Unit step Input with PID Controller

<b>Time Domain</b>	<b>PID</b>
<b>Delay Time(s)</b>	<b>6</b>
<b>Rise Time(s)</b>	<b>4.21</b>
<b>Settling Time(s)</b>	<b>27</b>
<b>Peak Overshoot (%)</b>	<b>11.8</b>
<b>Steady State Error</b>	<b>0</b>

The unit step response of wind turbine pitch control system is shown in Fig. 5.5. Time domain specifications are observed from the response graphs and tabulated in Table 7. With PID controller, we observed less rise time (4.2sec) , settling time (27%) and peak overshoot of 11.8% when compared to the wind turbine model without any controllers.

#### 5.4 Implementation of Fuzzy Logic Controller

First the rules-surface diagrams for each parameter  $K_p$ ,  $K_i$ ,  $K_d$  are shown in the figures 5.6, 5.7 and 5.8. Then all the 49 rules are displayed in the figure 5.9. Finally, the Simulink model of wind turbine pitch control system with fuzzy logic is shown in Fig. 5.10 and the subsystems are shown in Fig 5.11 and Fig 5.12.

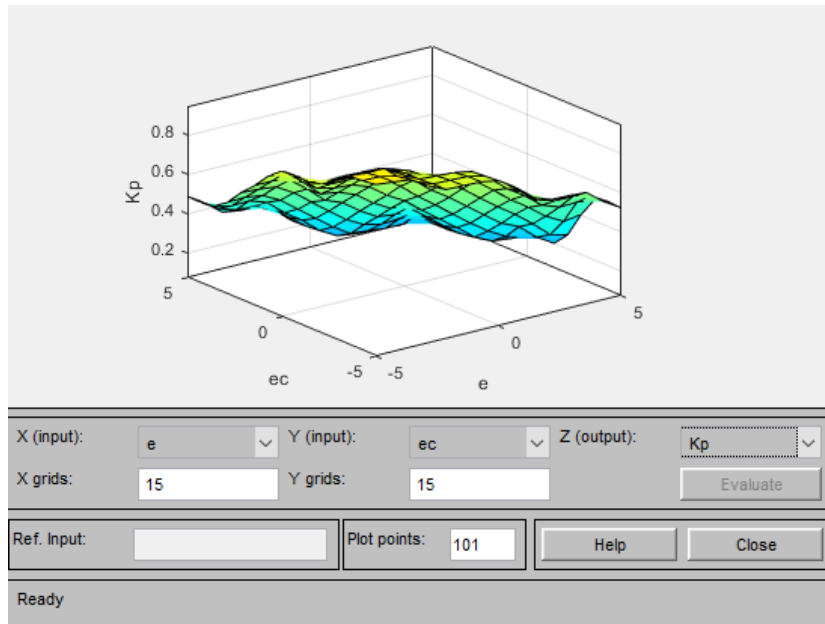

Figure 5.6: Surface Rule Diagram for Kp

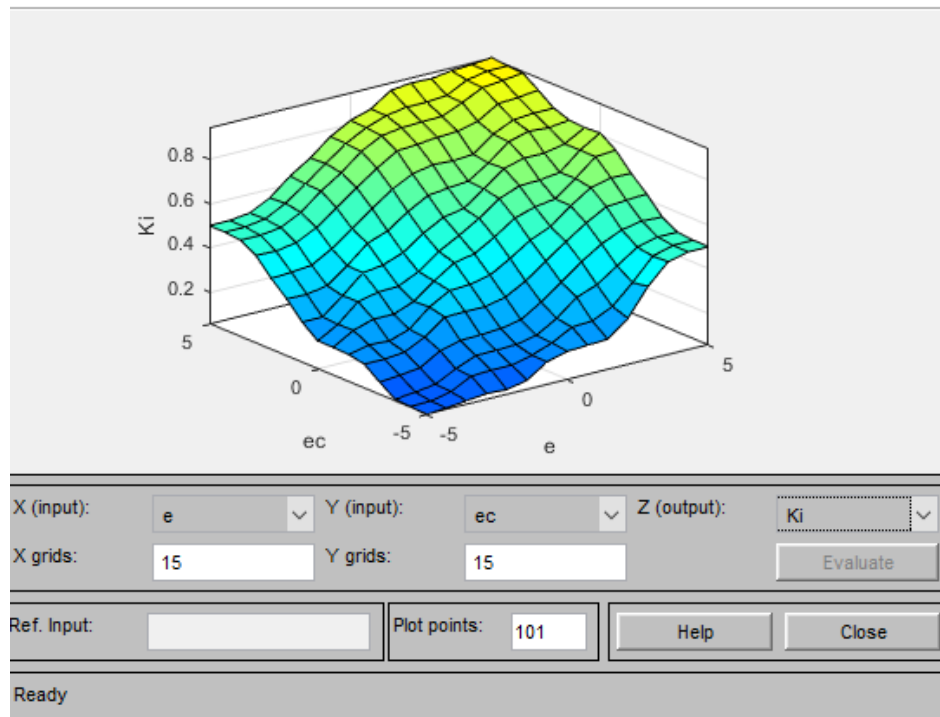

Figure 5.7: Surface Rule for Ki

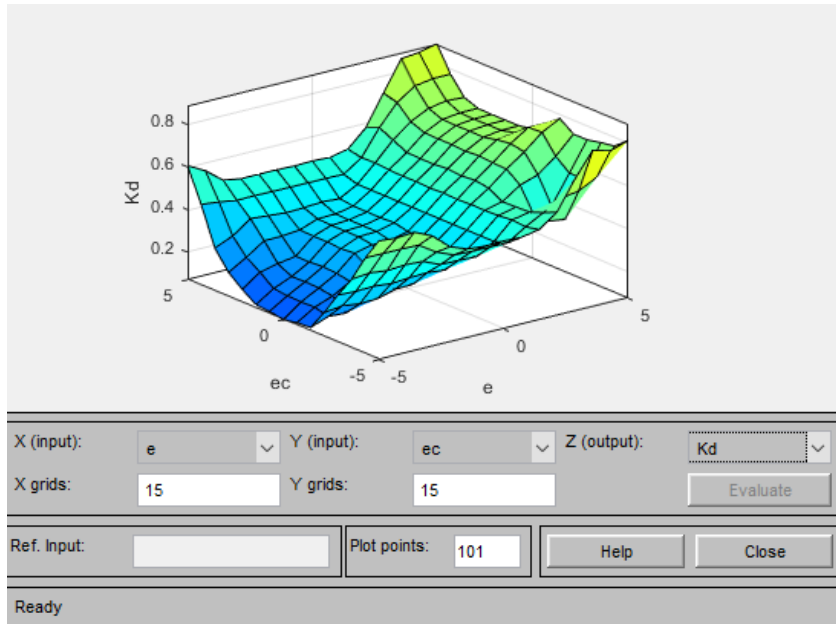

Figure 5.8 :Surface Rule Diagram for Kd

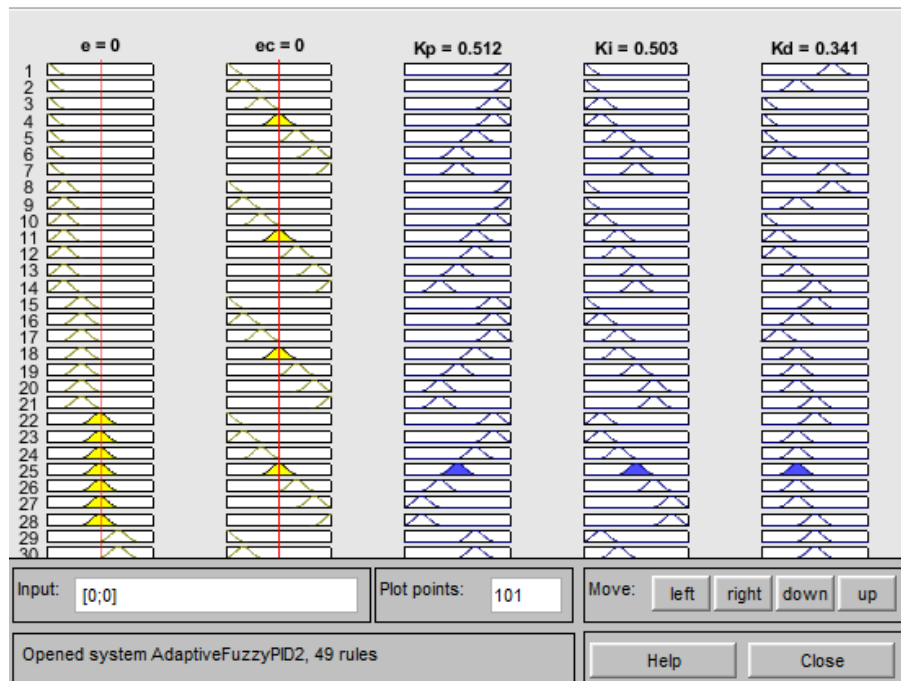

Figure 5.9 Rule Viewer for Fuzzy Controller



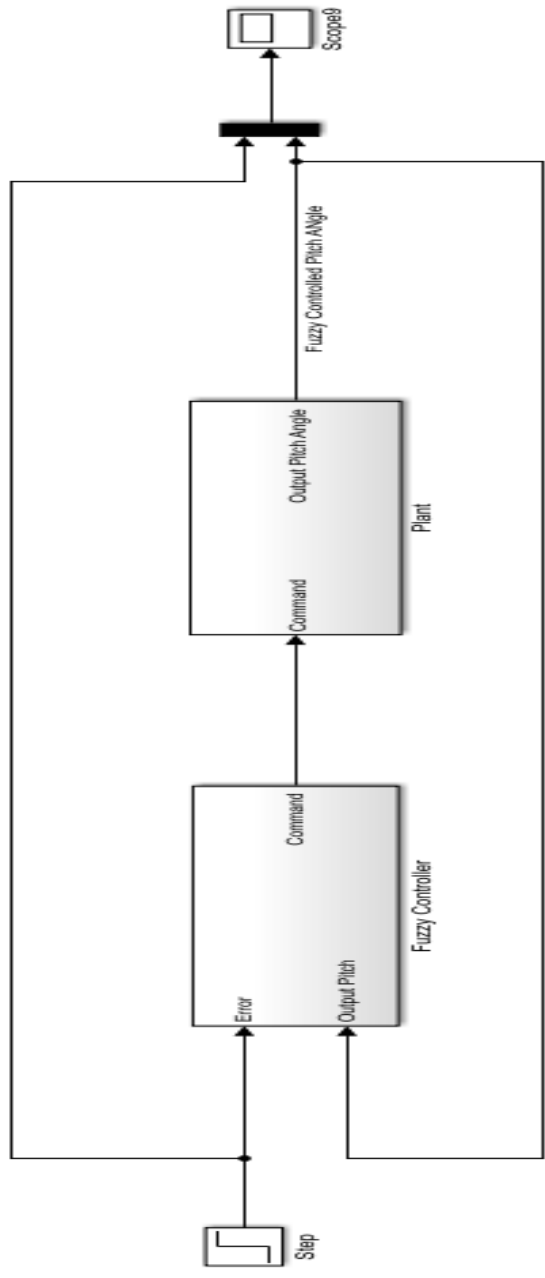

Figure 5.10 :Simulation diagram of fuzzy controller for pitch control system

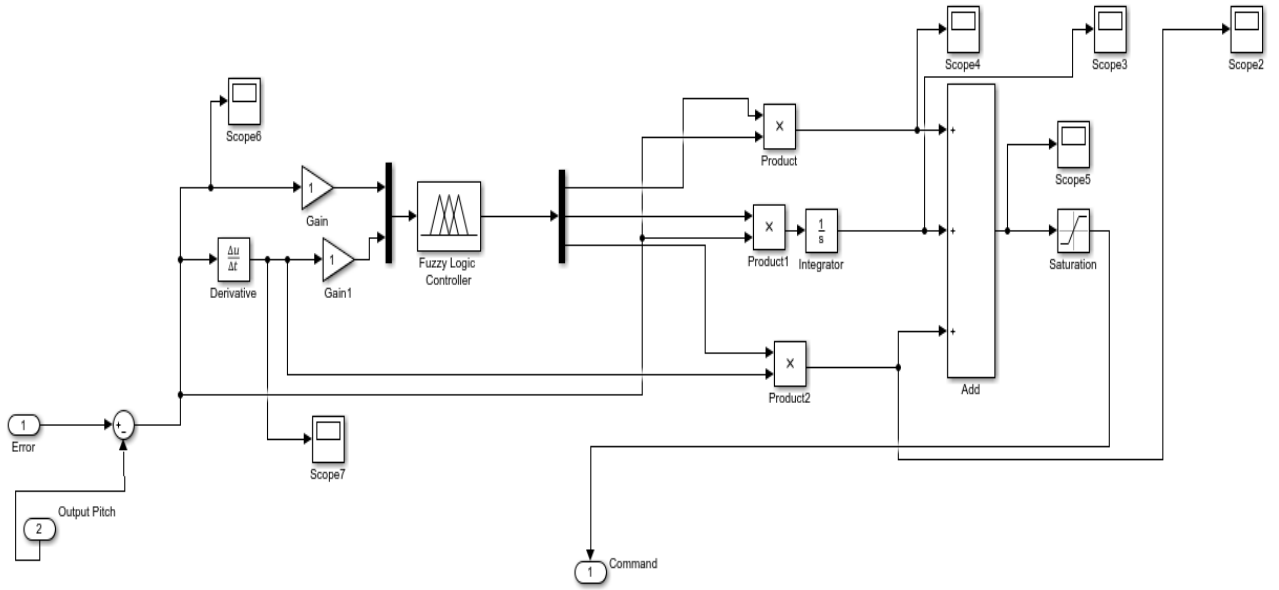

Figure 5.11: Fuzzy Controller Subsystem

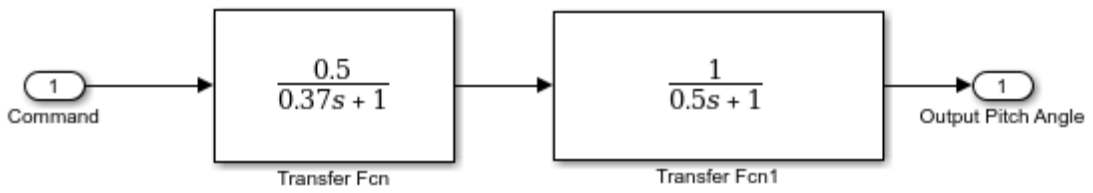

Figure 5.12: Plant Subsystem

## 5.5 Simulation of the Plant with Fuzzy Controller

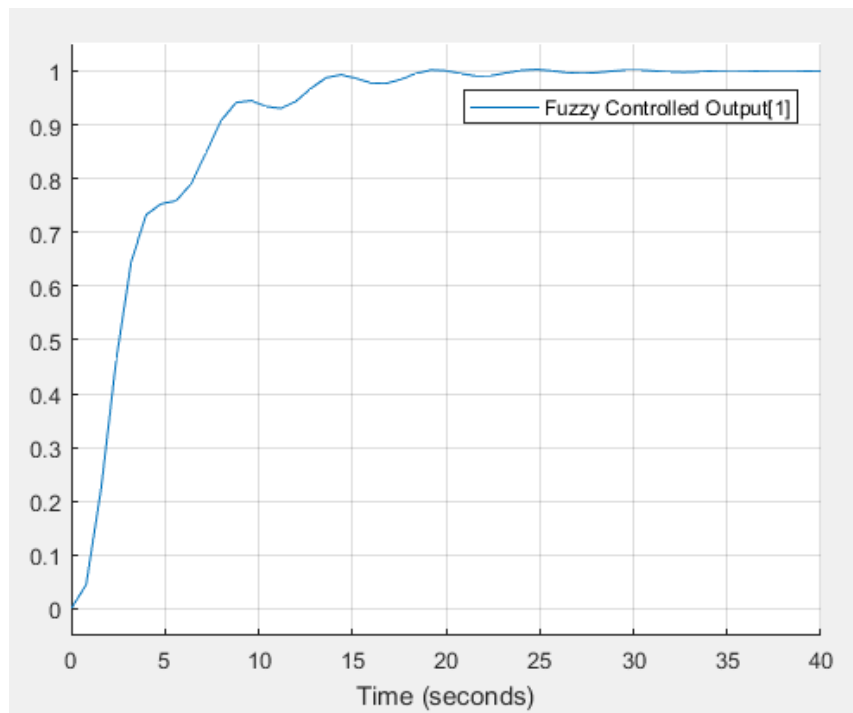

Figure 5.13: The unit step response of wind turbine with Fuzzy controller

Table 8: Time Domain Specification for Unit step Input with Fuzzy Controller

<b>Time Domain</b>	<b>Fuzzy</b>
<b>Delay Time(s)</b>	<b>4</b>
<b>Rise Time(s)</b>	<b>6.81</b>
<b>Settling Time(s)</b>	<b>25</b>
<b>Peak Overshoot (%)</b>	<b>0.5</b>
<b>Steady State Error</b>	<b>0</b>

The unit step response of wind turbine pitch control system is shown in Fig. 5.13. Time domain specifications are observed from the response graphs and tabulated in Table 8. With fuzzy controller, we observed more rise time (6.81sec) and less settling time (25sec) compared to conventional PID controller and a very little overshoot (0.5%).

## 5.6 Implementation of Fuzzy Adaptive PID Controller

The Simulink model of wind turbine pitch control system with fuzzy adaptive PID controller is shown in Fig. 5.14.

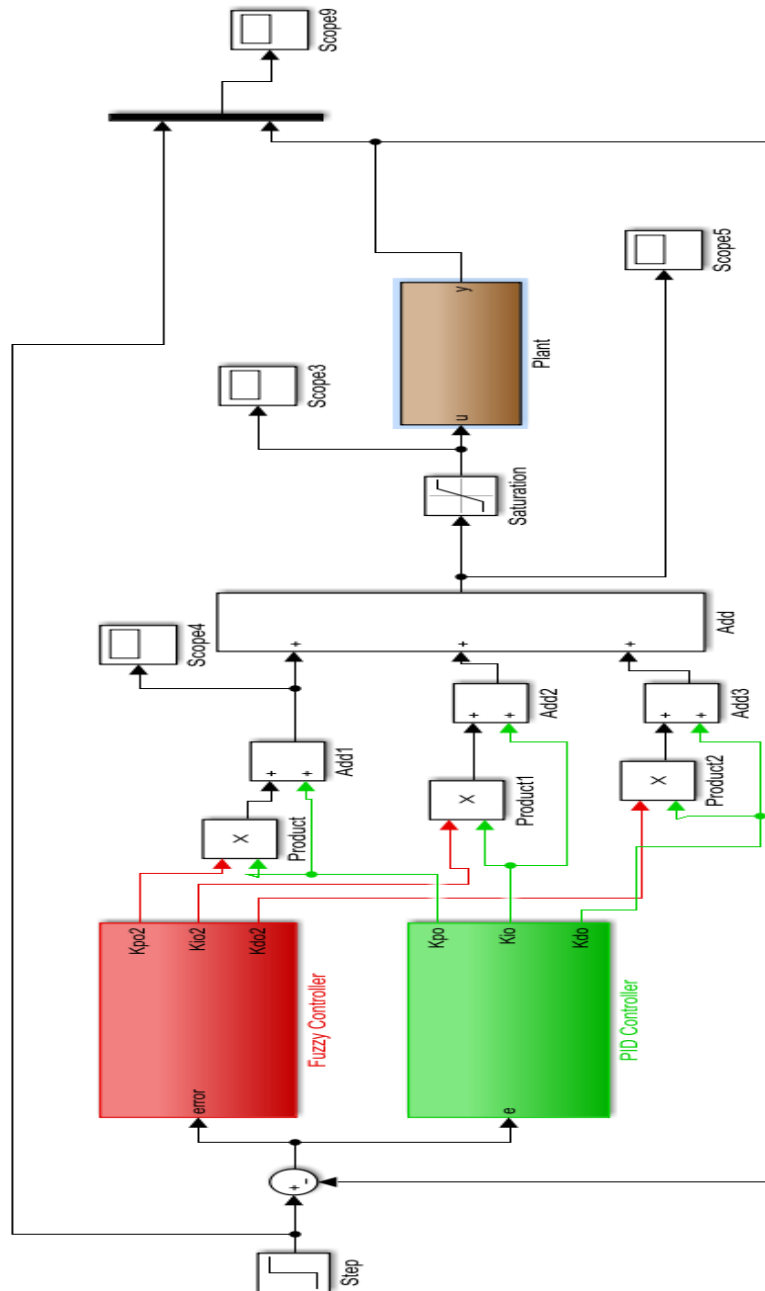

Figure 5.14: Simulation diagram of Adaptive fuzzy-PID controller for pitch control system

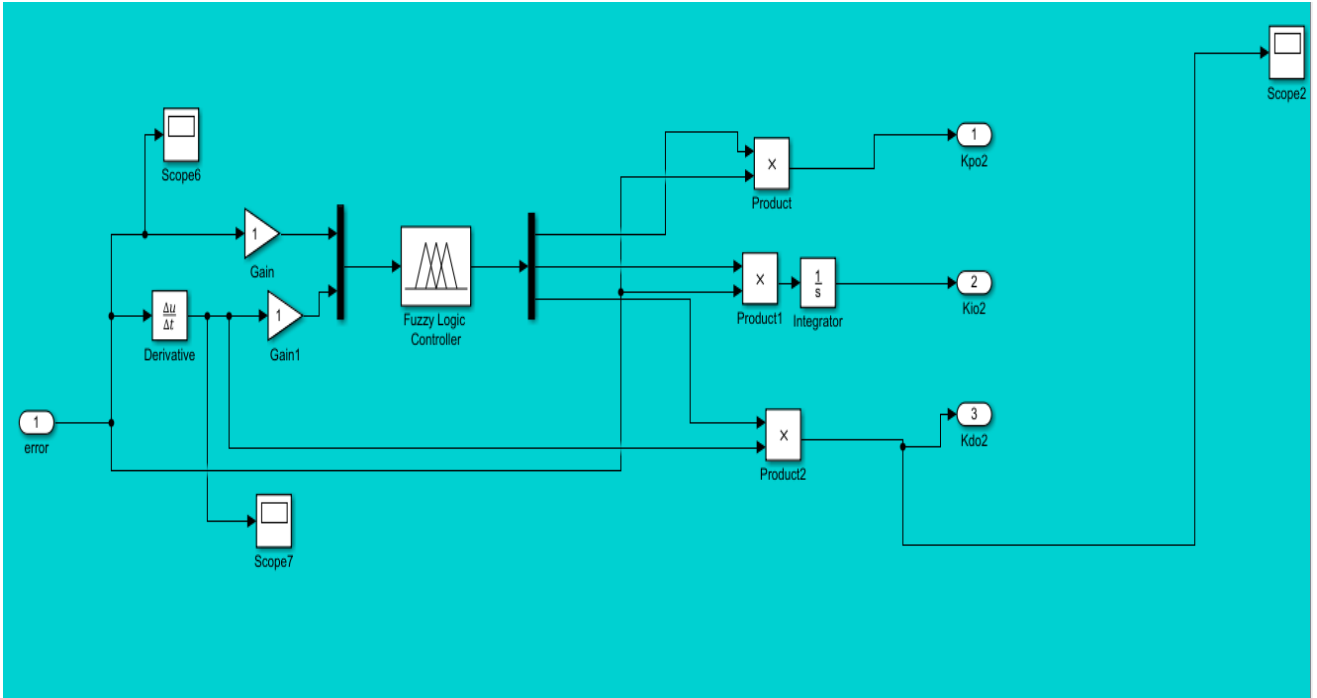

Figure 5.15:Subsystem- Fuzzy Controller

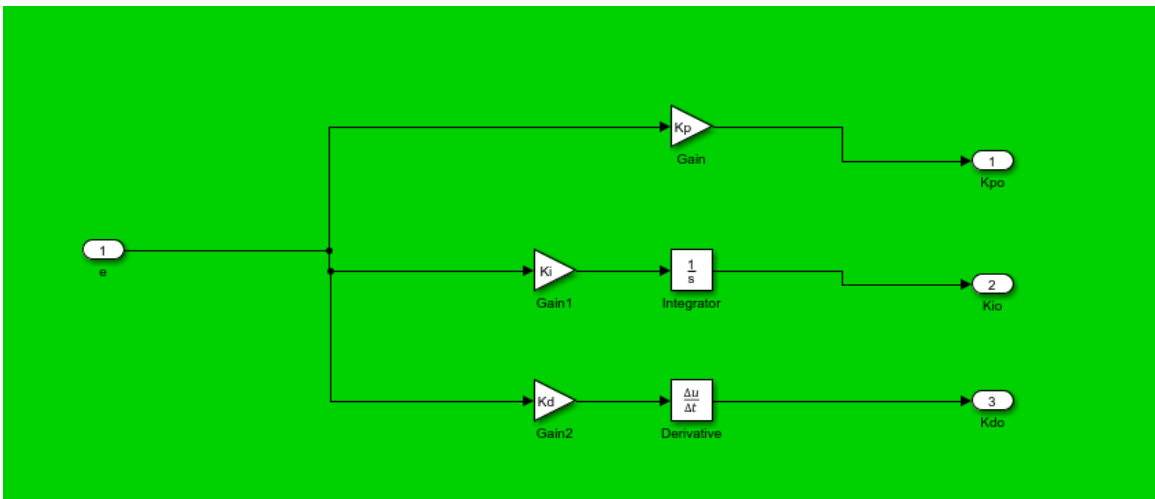

Figure 5.16 :Subsystem- PID Controller

Values for PID are  $K_p= 0.5$ ,  $K_i=0.75$ ,  $K_d=0$

## 5.7 Simulation of the Plant with an Adaptive Fuzzy-PID Controller

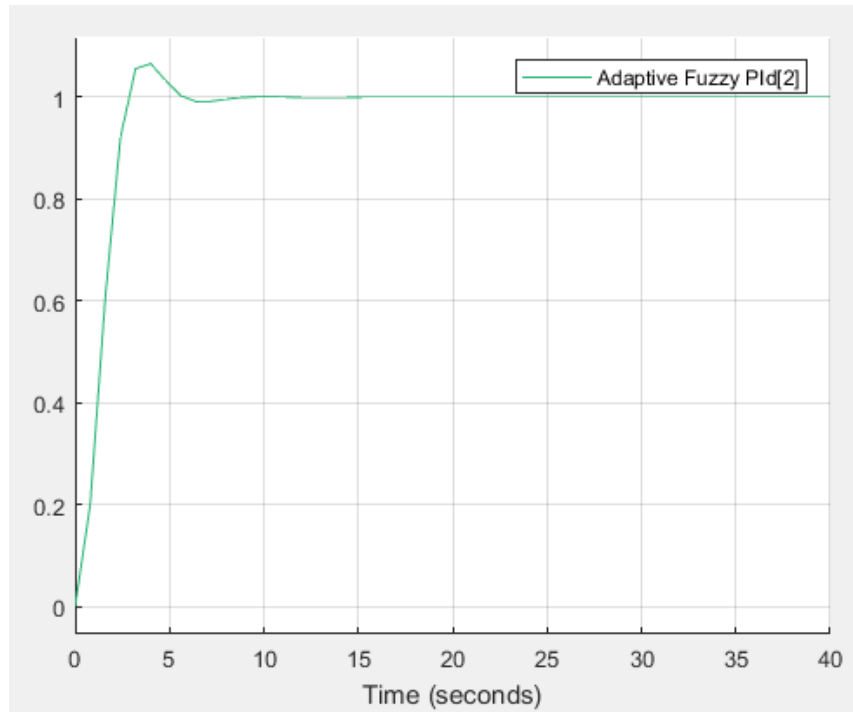

Figure 5.17: The unit step response of wind turbine with Adaptive Fuzzy PID controller

Table 9: Time Domain Specification for Unit step Input with an Adaptive Fuzzy-PID Controller

Time Domain	Adaptive Fuzzy-PID
<b>Delay Time(s)</b>	<b>3.5</b>
<b>Rise Time(s)</b>	<b>0.63</b>
<b>Settling Time(s)</b>	<b>8</b>
<b>Peak Overshoot (%)</b>	<b>0.02</b>
<b>Steady State Error</b>	<b>0</b>

The unit step response of wind turbine pitch control system is shown in Fig. 5.17. Time domain specifications are observed from the response graphs and tabulated in Table 9. With Fuzzy Adaptive PID controller, we observed very less settling time (8 sec) compared to both conventional PID and fuzzy logic controller and almost no overshoot (only 0.02%). This is because the damping coefficient after adding an Adaptive Fuzzy-Pid controller is greater than 1 value which results in system being overdamped and hence no

overshoot. However, the performance is not better in terms of rise time when compared to conventional PID controller.

### 5.8 Comparison of Simulation Results of the Plant using PID, Fuzzy and an Adaptive Fuzzy-PID Controller

The unit step responses of wind turbine pitch control system using fuzzy and fuzzy adaptive PID controllers are compared and shown in Fig. 5.18.

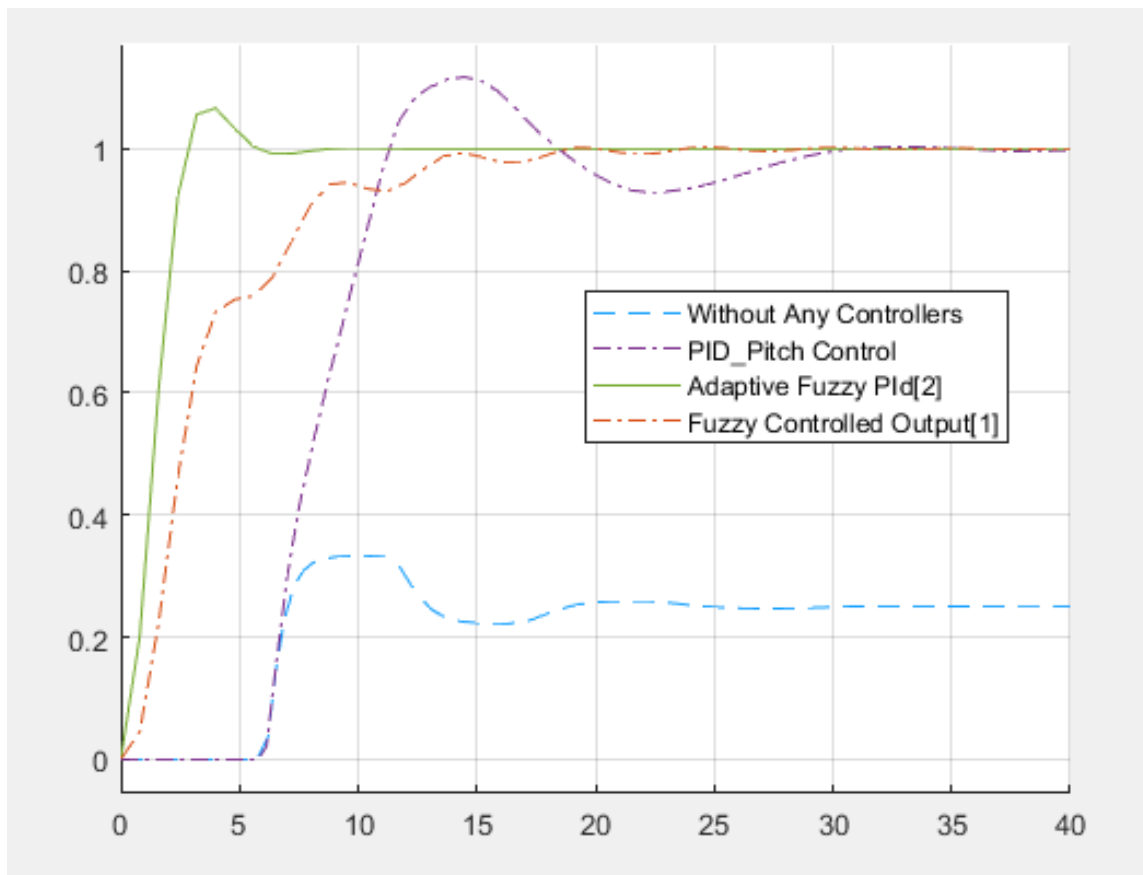

Figure 5.18: Comparison of unit step response of wind turbine pitch controllers

Table 10: Comparison of Time Domain Specifications of Pitch Control System for Unit Step Input Using Conventional Pid, Fuzzy, Fuzzy Adaptive Pid Controllers

<b>Time Domain</b>	<b>Without Controller</b>	<b>PID</b>	<b>Fuzzy</b>	<b>Adaptive Fuzzy-PID</b>
<b>Delay Time(s)</b>	<b>8</b>	<b>6</b>	<b>4</b>	<b>3.5</b>
<b>Rise Time(s)</b>	<b>0.813</b>	<b>4.21</b>	<b>6.81</b>	<b>0.63</b>
<b>Settling Time(s)</b>	<b>38</b>	<b>27</b>	<b>25</b>	<b>8</b>
<b>Peak Overshoot (%)</b>	<b>32.157</b>	<b>11.8</b>	<b>0.5</b>	<b>0.02</b>
<b>Steady State Error</b>	<b>0.75</b>	<b>0</b>	<b>0</b>	<b>0</b>

From the Table above and Fig.5.18, we can see that the Adaptive Fuzzy PID controller has the best response when compared to the other controllers. The settling time is fast (8sec) and overshoot is very less (only 0.02%), hence the Adaptive Fuzzy PID gives a better control for the pitch angle of the wind turbine system.



## Chapter 6- Conclusion and Future Works

In this paper, we developed the wind turbine pitch control system mathematical model and simulated with conventional PID, fuzzy and fuzzy adaptive PID controllers using MATLAB/Simulink. We compared the responses in terms of time domain specifications for unit step input using conventional PID, fuzzy and fuzzy adaptive PID controllers. Even though, the PID controller produces the response with lower delay time and rise time, it has oscillations with a peak overshoot of 11.8%, which causes the damage in the system performance. To suppress these oscillations fuzzy logic controller is proposed to use. From the results, it can be observed that, this controller can effectively suppress the oscillations and produces smooth response, but it has more delay time, rise time and settling time which is also better than the fuzzy controller response in [6]. By using fuzzy adaptive PID controller, where the PID gains are tuned by using fuzzy logic concepts, the results showed that this design can effectively suppress the steady state error to zero and the system has minimum delay time (3.5 seconds), fast rising time (0.63seconds), quick settling time (8 seconds) and better stability. From the analysis, we conclude that fuzzy adaptive PID controller gives relatively fast response for unit step input. This technique is much better to realize the control of pitch system and to guarantee the stability of wind turbine output power. In future, one can use artificial neural networks to control the pitch angle of the wind turbine system and check its performance with the Adaptive Fuzzy PID controller. Also, Individual pitch control method can be used along with the Adaptive Fuzzy PID controller to improve the overall performance of the system.

## References

- [1] A.V.A. Macedo, and W.S. Mota, "Wind Turbine Pitch Angle Control Using Fuzzy Logic," IEEE, pp. 1-6, 2012.
- [2] A. Rolán, "An Approach to the Performance-Oriented Model of Variable-Speed Wind Turbines," 978-1-4244-6392-3IEEE, pp 3853-3858, 2010.
- [3]. Civelek, Zafer, Ertuğrul Çam, Murat Lüy, and Hayati Mamur. "Proportional–integral–derivative Parameter Optimisation of Blade Pitch Controller in Wind Turbines by a New Intelligent Genetic Algorithm," *IET Renewable Power Generation*, vol. 10, pp.1220-1228, 2016.
- [4] C. Tan and H. Wang, "A Review on Pitch Angle Control Strategy of Variable Pitch Wind Turbines," *Advanced Materials Research*, vol. 772, pp. 744-748, 2013.
- [5] Dunne, F. "Optimizing Blade Pitch Control of Wind Turbines with Preview Measurements of the Wind." Order No. 10108716 University of Colorado at Boulder, 2016.
- [6]. Han, Bing, Lawu Zhou, Fan Yang, and Zeng Xiang, "Individual Pitch Controller Based on Fuzzy Logic Control for Wind Turbine Load Mitigation," *IET Renewable Power Generation*, vol.10.5, pp.687-693, 2016.
- [7] H. Bevrani, F. Daneshfar & R. P. Daneshmand, "Intelligent Power System Frequency Regulations Concerning the Integration of Wind Power Units," Retrieved from [http://link.springer.com/chapter/10.1007/978-3-642-13250-6\\_15](http://link.springer.com/chapter/10.1007/978-3-642-13250-6_15).
- [8] "History of Wind Power | Horizon Energy Curriculum," *Horizoncurriculum.com*, <https://www.horizoncurriculum.com/supportmaterial/history-of-wind-power/>

- [9] “Jason T Brown. Montana environmental information centre,” 2013, Retrieved from <http://meic.org>.
- [10] Kira Grogg, “Harvesting the Wind: The Physics of Wind Turbines,” *Physics and Astronomy Department*, Carleton College, 2005.
- [11] L. Suganthi, S. Iniyar, Anand A. Samuel, “Applications of fuzzy logic in renewable energy systems,” *A review, Renewable and Sustainable Energy Reviews*, vol.48, pp.585-607, 2015, <http://dx.doi.org/10.1016/j.rser.2015.04.037>.
- [12] Novak P, Ekelund T, Jovik I, and Schmidt Bauer B. "Modeling and Control of Variable-Speed Wind-Turbine Drive-System Dynamics," *IEEE Control System Magazine*, Vol.15(4), pp. 28-38, 1995.
- [13] Paulo J. Costa , Adriano S. Carvalho , & António J. Martins, “Fuzzy Logic as a Method to Optimize Wind Systems Interconnected with the Smart Grid,” 2017, from [http://link.springer.com/chapter/10.1007/978-3-642-13250-6\\_14](http://link.springer.com/chapter/10.1007/978-3-642-13250-6_14)
- [14] R. Carlos Barria, “Wind Power,” *Nationalgeographic.com*, 2017. Retrieved from <http://www.nationalgeographic.com/environment/global-warming/wind-power/>.
- [15] R. M, “Dynamics and Structural Loading in Wind Turbines,” Vol.1. 2017.
- [16] Sharma, R.D., ‘Feedforward Learning Control for Individual Blade Pitch Control of Modern Two-Bladed Wind Turbines,’2013.
- [17] S.Suryanarayanan, A.Dixit, "Control of Large Wind Turbines: Review and Suggested Approach to Multivariable Design", *Proc. of the American Control Conference USA*, pp. 686-690,2005.
- [18] Tao Yonghua, “ New Type PID Control and its Application”.2008

- [19] Tajhau, "The Inside of a Wind Turbine," Beijing: Mechanical Industry Press, 2002
- [20] W. Tong. *Wind Power Generation and Wind Turbine Design*, pp.55-70. 2010.
- [21] X. Yin *et al*, "Design, modeling and implementation of a novel pitch angle control system for wind turbine," *Renewable Energy*, vol. 81, pp. 599-608, 2015
- [22] Y. Qi and Q. Meng, "The Application of Fuzzy PID Control in Pitch Wind Turbine", *Energy Procedia*, vol. 16, pp. 1635-1641, 2012.
- [23]. Zhang, Dahai, Philip Cross, Xiandong Ma, and Wei Li. "Improved Control of Individual Blade Pitch for Wind Turbines." *Sensors & Actuators*, vol.8 , pp. 12-18, 2013.
- [24] Z. Shahan, "History of Wind Turbines", 2014, Retrieved from <http://www.renewableenergyworld.com/ugc/articles/2014/11/history-of-wind-turbines.html>

## Appendix-MATLAB Codes

Code for plotting the Relationship between wind velocity and power of wind

```
%Code for plotting the Relationship between wind velocity and power of
wind
clear all
clc
vc = 3 ;
vr = 12;
vf = 25;
step = 0.01;
v = step : step : 25;
P = zeros(1, length(v));
index = 1;
for v1 = step : step : vc
P(index) = 0;
index = index + 1;
end
for v2 = vc+step : step : vr
r = 50; % in meters, indicates the blade length
A = pi * (r^2);
Raw = 1.225; % Air Density, in kg/m3
P(index) = 0.5 * A * (v2^3) * Raw ; % Cubic relation
index = index + 1;
end
Prated = P(index-1);
for v3 = vr+step : step : vf
P(index) = Prated;
index = index + 1;
end
plot(v,P/(10^6));
title ('Theoretical Power Curve')
xlabel('Wind Velocity (m/s)')
ylabel('Output Power (MW)')
```

Code of Weibull distribution plot between wind velocity and probability

```
%Code of Weibull distribution plot between wind velocity and
probability
% Weibull Distribution
v = 0: 0.01 : 25;
a = 7; % scale parameter
b = 2; % shape parameter
P = wblpdf(v,a,b); % weibull probability ditribution
plot(v,P)
title ('Weibull distribution Plot ')
xlabel('Wind Velocity (m/s)')
ylabel('Probability')
```

## Code showing the effect of the pitch angle on the output power

```
%The code shows the effect of the pitch angle on the output power
% Power curve plot
clear all
clc
vc = 3 ;
vr = 12;
vf = 25;
step = 0.01;
v = step : step : 25;
P = zeros(1, length(v));
index = 1;
for PitchAngle = 0:5:20
P = zeros(1, length(v));
index = 1;
for v1 = step : step : vc
P(index) = 0;
index = index + 1;
end
for v2 = vc+step : step : vr
R = 50;
f = 0.2;
w = 2*pi*f; % in meters, indicates the blade length
A = pi * (R^2);
Raw = 1.225; % Air Density, in kg/m³
lamda = w*R/v2;
c = [0.5 116 0.4 0 5 21];
x = 20;
ghama = 1./(1./(lamda+0.08*PitchAngle)-0.035/(1+(PitchAngle^3)));
Cp = c(1).*(c(2)./ghama-c(3).*PitchAngle-c(4).*(PitchAngle^x)-
c(5)).*(exp(-c(6)./ghama));
P(index) = 0.5 * A * (v2^3) * Raw * Cp; % Cubic relation
index = index + 1;
end
Prated = P(index-1);
for v3 = vr+step : step : vf
P(index) = Prated;
index = index + 1;
end
for h= 1: length(P)
if P(h) < 0
P(h) = 0;
end
end
plot(v,P/(10^6));
title ('Power Curve')
xlabel('Wind Velocity (m/s)')
ylabel('Output Power (MW)')
hold on
end
```